

GENERAL DESCRIPTION

The ACP2728 is a boost DC/DC converter that drives WLEDs with a 40V voltage rated switch MOSFET, thus it can drive single or parallel WLED strings for small to large size panel back-lighting. The default white LED current is set with the external sensor resistor, and the feedback voltage is regulated to 200mV, as shown in the typical application. During the operation, the WLED current can be controlled by a PWM signal applied to The EN pin, through which the duty cycle determines the feedback reference voltage. For Maximum protection, the device features integrated open protection that disables the ACP2728 to prevent the output voltage from exceeding the absolute maximum voltage ratings during open LED Conditions.

FEATURES

- Input Voltage Range: 2.7V to 5.5V
- 200mV Reference Voltage
- Integrated 2.7A Current Limit MOSFET
- Fixed 1.2MHz Switching Frequency
- PWM Brightness Control
- Under-Voltage Protection
- Low EMI and Improved PSRR
- Up to 93% Efficiency
- Built-In Soft-Start Function
- Thermal Shutdown
- TSOT-25 Tiny Package

APPLICATION

- TFT Panel Backlighting
- Portable LED Lamp

APPLICATION CIRCUIT

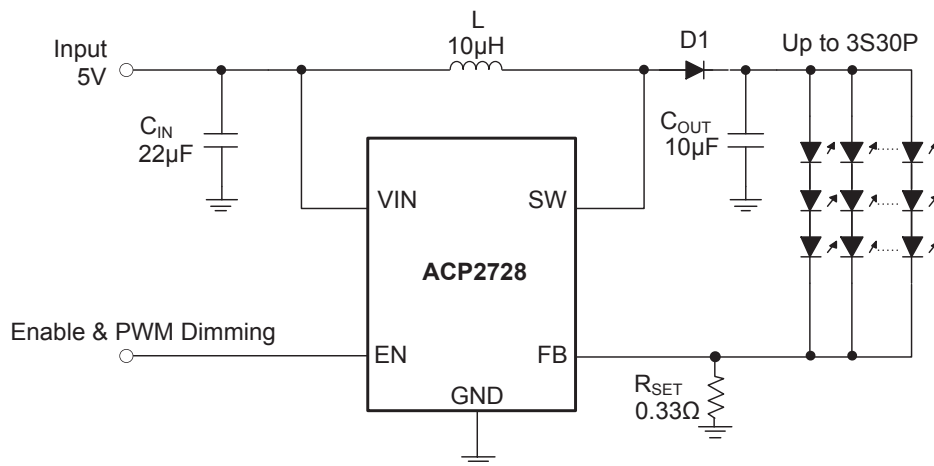

Typical ACP2728 Application Circuit

▼ PIN CONFIGURATION

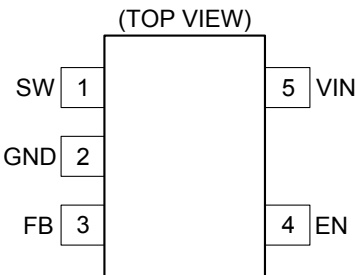
Pin Configuration	Pin Description		
<p>TSOT25</p> <div style="text-align: center;"> <p>(TOP VIEW)</p>  </div>	Pin#	Symbol	Function
	1	SW	Drain Connection of The Internal Power FET
	2	GND	Ground Pin
	3	FB	Feedback Input
	4	EN	PWM Dimming Signal Input
	5	VIN	Input Supply Pin

▼ ORDERING INFORMATION

Standard Part NO.	Package	Packing	Min. Quantity
ACP2728-DAA	TSOT25	Tape & Reel	3000PCS

▼ ABSOLUTE MAXIMUM RATINGS

Parameter	Symbol	Rating	Unit
Supply Pin Voltage	V_{IN}	-0.3 to +6	V
Feedback Pin Voltage	V_{FB}	-0.3 to +6	V
Dimming Signal Input Voltage	V_{EN}	-0.3 to +6	V
Switch Pin Voltage	V_{SW}	-0.3 to +40	V
Storage Temperature	T_S	-65 to +150	°C
Junction Temperature	T_J	+150	°C
Lead Temperature	T_L	+260	°C
Human Body Model	HBM	3000	V
Charged Device Model	CDM	1000	VV
Junction to Ambient	θ_{JA}	190	°C/W

■ ELECTRICAL CHARACTERISTICS (T_A=25°C)

Parameter	Symbol	Conditions	Min	Typ	Max	Unit
Input Voltage Range	V _{IN}		2.7		5.5	V
Operating Quiescent Current into VIN	I _Q	V _{FB} = 300mV		0.2	0.35	mA
V _{IN} Undervoltage Lockout Falling Threshold	V _{UVLO}	V _{IN} falling		2.2		V
		V _{IN} rising		2.3	2.5	
UVLO Hysteresis	V _{HYS}			100		mV
Shutdown Current	I _{SD}	EN = GND			1	μA
N-Channel MOSFET On-Resistance	R _{DS(ON)}			0.2	0.3	Ω
Voltage Feedback Regulation Voltage	V _{REF}	PWM duty cycle 100%	194.5	200	207	mV
		PWM duty cycle 10%	18.5	20	21.5	
		PWM duty cycle 1%	1.4	2.2	3	
		PWM duty cycle 0.2%		0.65		
FB Pin Bias Current	I _{FB}	V _{FB} = 100mV		0.6	1	μA
VREF Filter Time Constant	t _{REF}			0.1		ms
Switching Frequency	f _{SW}		0.9	1.2	1.35	MHz
Switching MOSFET Current Limit	I _{LIM}		2.3	2.75	3.2	A
Output Voltage Over-Voltage Threshold	V _{OVP_SW}		36	38	39.5	V
EN Logic High Voltage	V _H		1.5			V
EN Logic Low Voltage	V _L				0.4	V
EN Pin Internal Pull-Down Resistor	R _{PD}			600		kΩ
EN Logic Low Time to Shutdown	t _{SD}	EN high to low	2.5			ms
PWM Dimming Frequency Range			10		100	kHz
Minimum PWM On-Time			40			ns
PWM Duty Cycle Changing Time to Output		Duty cycle from 100% to 50%		2		ms
Stable Dimming Range			0.2		100	%
Thermal Shutdown Threshold	T _{SHUTDOWN}			160		°C
Thermal Shutdown Hysteresis	T _{HYS}			20		°C

PERFORMANCE CHARACTERISTICS

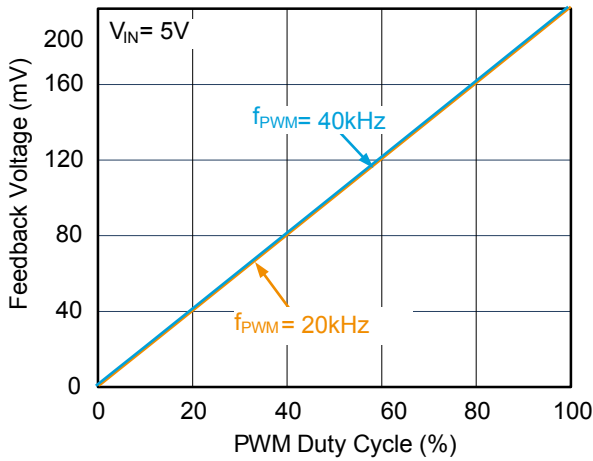

Feedback Voltage vs. PWM Duty Cycle

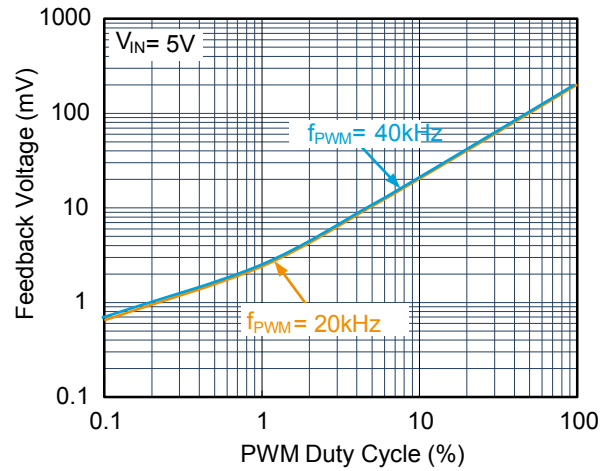

Feedback Voltage vs. PWM Duty Cycle

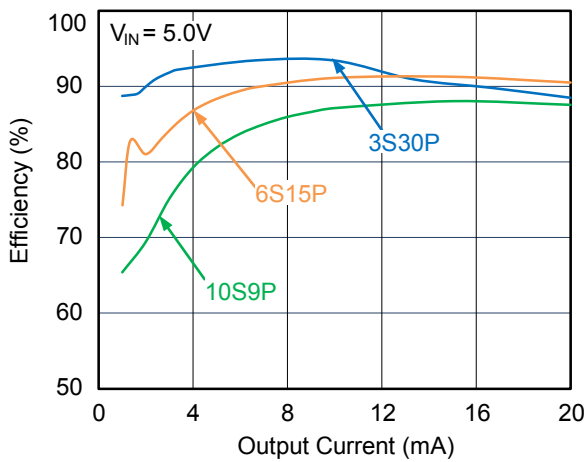

Efficiency vs. Output Current

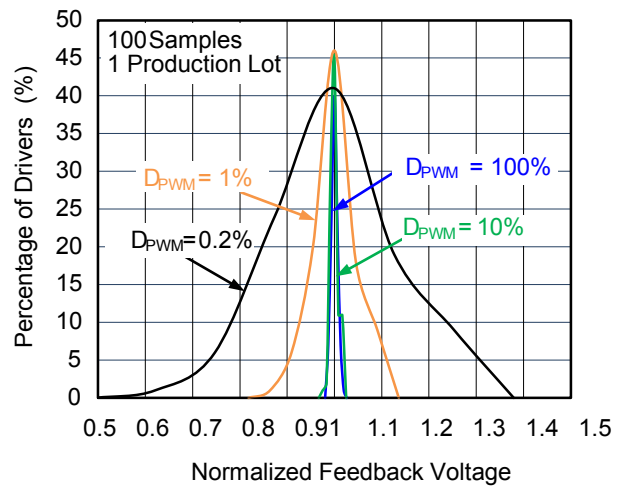

Feedback Voltage Production Distribution

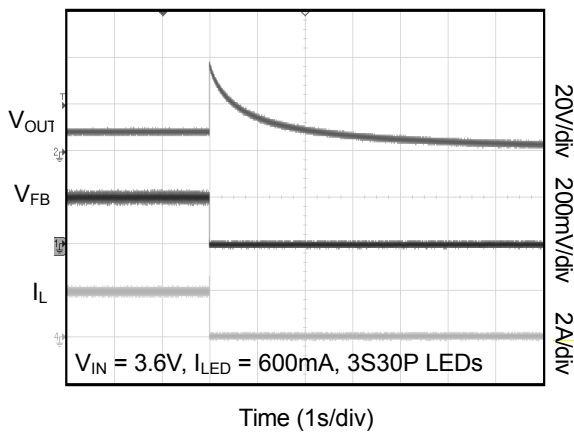

Open LED Protection

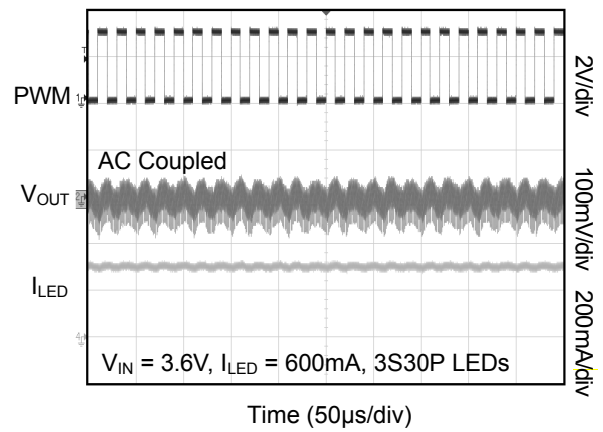

Output Ripple at PWM Dimming

▼ **FUNCTION BLOCK**

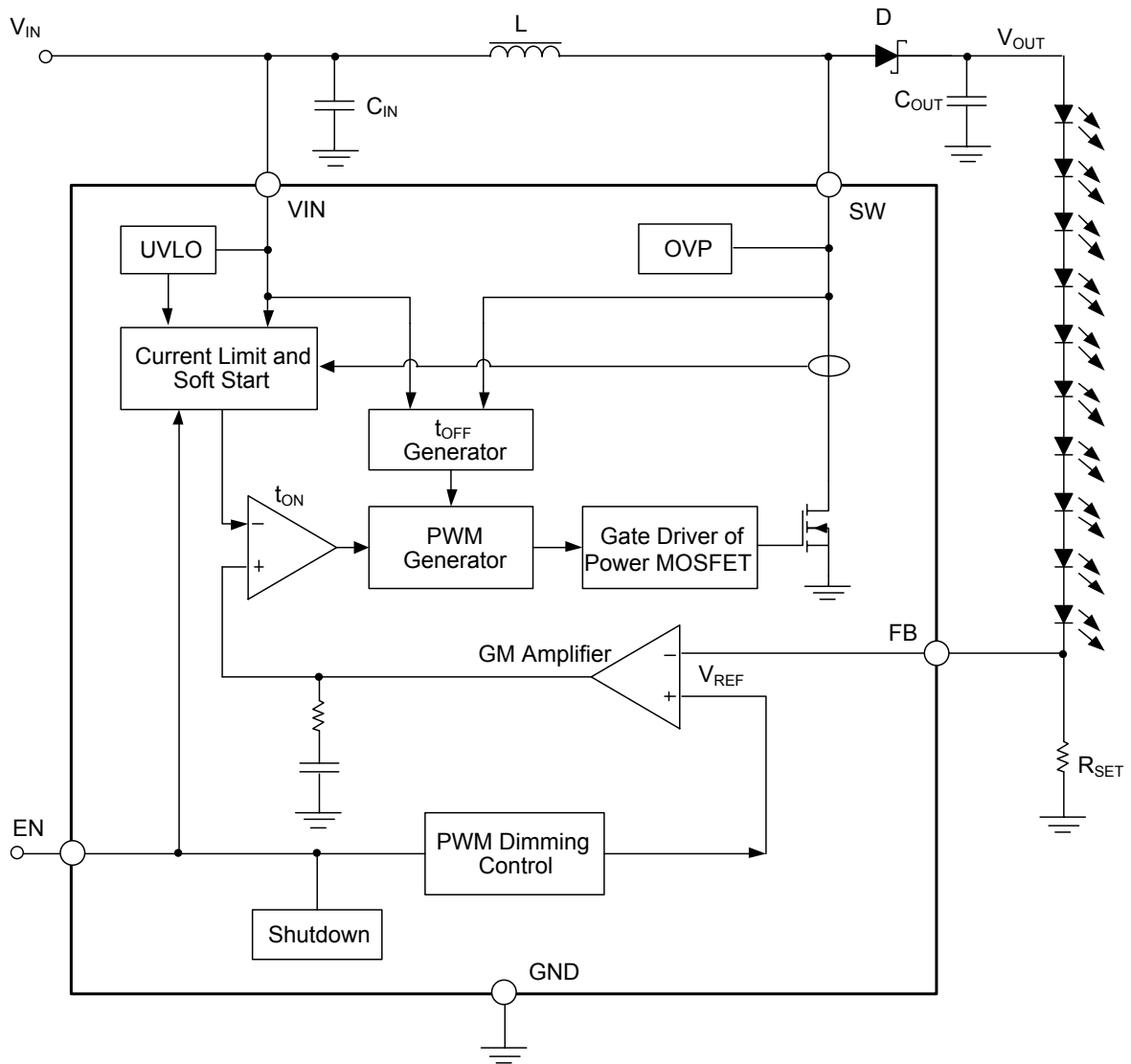

ACP2728 Functional Block Diagram

PACKAGE INFORMATION

- TSOT25

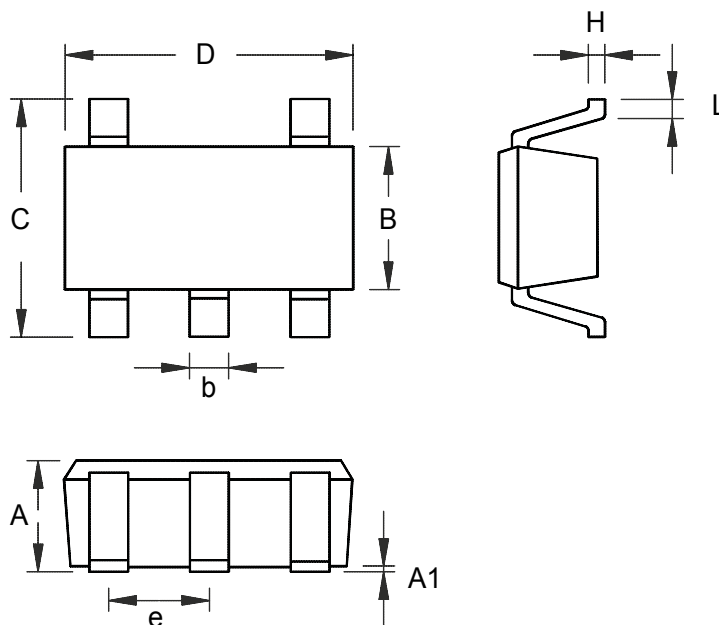

Symbol	Dimensions In Millimeters		Dimensions In Inches	
	Min	Max	Min	Max
A	0.700	0.900	0.028	0.035
A1	0.000	0.100	0.000	0.004
B	1.600	1.700	0.028	0.031
b	0.350	0.500	0.014	0.020
C	2.650	2.950	0.104	0.106
D	2.820	3.020	0.111	0.119
e	0.838	1.041	0.033	0.041
H	0.080	0.254	0.003	0.010
L	0.300	0.610	0.012	0.024