



SGM3752

38V High Efficiency, Boost WLED Driver with PWM Control

GENERAL DESCRIPTION

With a 40V rated integrated switch FET, the SGM3752 is a boost converter that drives LEDs in series. The boost converter has a 40V, 1.5A internal MOSFET; thus it can drive single or parallel LED strings for small to large size panel backlighting.

The default white LED current is set with the external sensor resistor, R_{SET} , and the feedback voltage is regulated to 200mV, as shown in the typical application. During the operation, the LED current can be controlled by using a pulse width modulation (PWM) signal applied to the CTRL pin, through which the duty cycle determines the feedback reference voltage. The SGM3752 does not burst the LED current; therefore, it does not generate audible noises on the output capacitor. For maximum protection, the device features integrated open LED protection that disables the SGM3752 to prevent the output voltage from exceeding the IC absolute maximum voltage ratings during open LED conditions.

The SGM3752 is available in Green TSOT-23-6 package. It operates over an ambient temperature range of -40°C to +85°C.

FEATURES

- **1:250 Stable Luminance Dimming**
- **Low EMI by Conducting Ringing Cancelling**
- **Improved PSRR for Waveless Lighting**
- **Input Voltage Range: 2.7V to 5.5V**
- **Integrated 40V, 1.5A Current Limit MOSFET**
- **38V Open LED Protection for 10 LEDs in Series**
- **1.2MHz Switching Frequency**
- **200mV Reference Voltage**
- **PWM Brightness Control**
- **Under-Voltage Protection**
- **Up to 90% Efficiency**
- **Built-in Soft-Start Function**
- **Thermal Shutdown**
- **-40°C to +85°C Operating Temperature Range**
- **Available in Green TSOT-23-6 Package**

APPLICATIONS

Smart Phone Backlighting

Tablet Backlighting

PDAs, Handheld Computers, GPS Receivers

Portable Media Players, Portable TVs

White LED Backlighting for Small and Media Form Factor Displays

38V High Efficiency, Boost WLED Driver with PWM Control

SGM3752

PACKAGE/ORDERING INFORMATION

MODEL	PACKAGE DESCRIPTION	SPECIFIED TEMPERATURE RANGE	ORDERING NUMBER	PACKAGE MARKING	PACKING OPTION
SGM3752	TSOT-23-6	-40°C to +85°C	SGM3752YTN6G/TR	G7CXX	Tape and Reel, 3000

NOTE: XX = Date Code.

Green (RoHS & HSF): SG Micro Corp defines "Green" to mean Pb-Free (RoHS compatible) and free of halogen substances. If you have additional comments or questions, please contact your SGMICRO representative directly.

MARKING INFORMATION

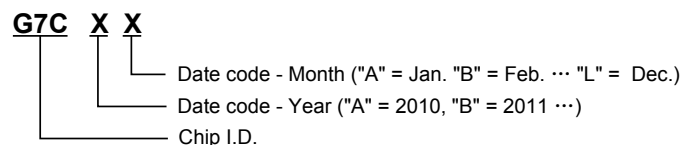

For example: G7CFA (2015, January)

ABSOLUTE MAXIMUM RATINGS

Voltage on VIN, CTRL, FB.....	-0.3V to 6V
Package Thermal Resistance	
TSOT-23-6, θ_{JA}	190°C/W
Voltage on SW.....	-0.3V to 40V
Junction Temperature.....	+150°C
Storage Temperature Range.....	-65°C to +150°C
Lead Temperature (Soldering, 10sec).....	+260°C
ESD Susceptibility	
HBM.....	2000V
MM.....	200V
CDM.....	1000V

RECOMMENDED OPERATING CONDITIONS

Input Voltage Range.....	2.7V to 5.5V
Output Voltage Range.....	V_{IN} to 38V
Inductor.....	4.7 μ H to 10 μ H
Input Capacitor.....	1 μ F (MIN)
Output Capacitor.....	1 μ F to 10 μ F
Operating Temperature Range.....	-40°C to +85°C

OVERSTRESS CAUTION

Stresses beyond those listed may cause permanent damage to the device. Functional operation of the device at these or any other conditions beyond those indicated in the operational section of the specification is not implied. Exposure to absolute maximum rating conditions for extended periods may affect reliability.

ESD SENSITIVITY CAUTION

This integrated circuit can be damaged by ESD if you don't pay attention to ESD protection. SGMICRO recommends that all integrated circuits be handled with appropriate precautions. Failure to observe proper handling and installation procedures can cause damage. ESD damage can range from subtle performance degradation to complete device failure. Precision integrated circuits may be more susceptible to damage because very small parametric changes could cause the device not to meet its published specifications.

DISCLAIMER

SG Micro Corp reserves the right to make any change in circuit design, specification or other related things if necessary without notice at any time.

PIN CONFIGURATION

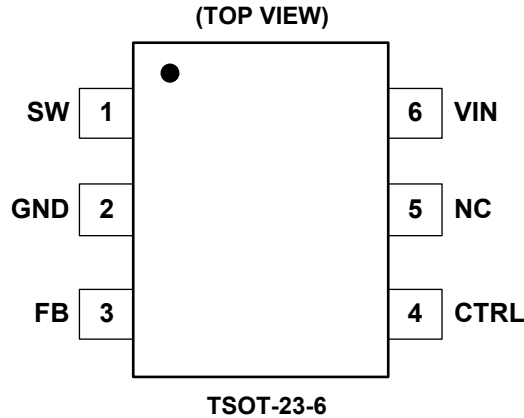

PIN DESCRIPTION

PIN	NAME	I/O	FUNCTION
1	SW	I	Drain Connection of The Internal Power FET.
2	GND	O	Ground.
3	FB	I	Feedback Pin for Current. Connect the sense resistor from FB to GND.
4	CTRL	I	PWM Dimming Signal Input.
5	NC	-	No Connection.
6	VIN	I	Input Supply Pin.

NOTE: I: input; O: output.

TYPICAL APPLICATION

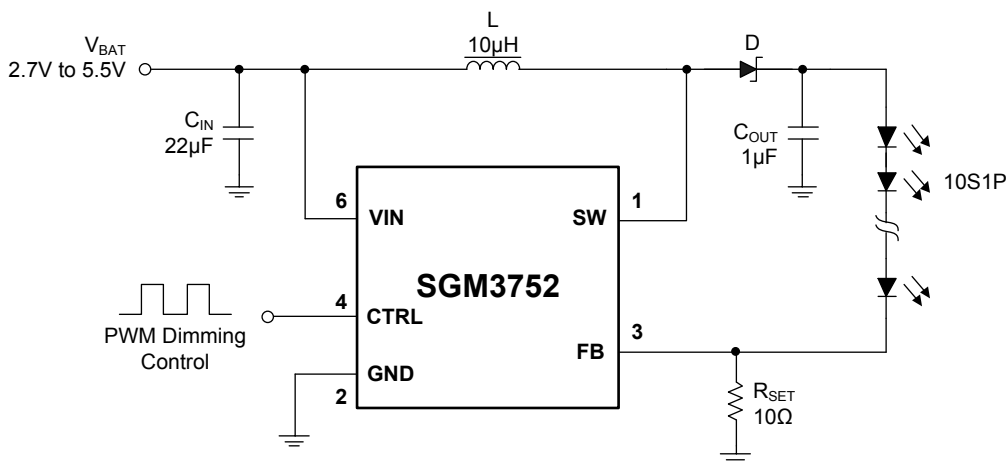

Figure 1. Typical Application

ELECTRICAL CHARACTERISTICS(V_{IN} = 3.6V, CTRL = V_{IN}, C_{IN} = 22μF, Full = -40°C to +85°C, typical values are at T_A = +25°C, unless otherwise noted.)

PARAMETER	SYMBOL	CONDITIONS	TEMP	MIN	TYP	MAX	UNIT
POWER SUPPLY							
Input Voltage Range	V _{IN}		Full	2.7		5.5	V
Under-Voltage Lockout Threshold	UVLO	V _{IN} falling	+25°C		2.2		V
		V _{IN} rising	+25°C		2.3	2.5	
UVLO Hysteresis	V _{HYS}		+25°C		100		mV
Operating Quiescent Current into V _{IN}	I _Q	V _{FB} = 400mV, no switching	+25°C		0.2	0.35	mA
Shutdown Current	I _{SD}	CTRL = GND	+25°C			1	μA
BOOST CONVERTER							
Voltage Feedback Regulation Voltage	V _{REF}	PWM duty cycle 100%	+25°C	193.5	200	205.3	mV
		PWM duty cycle 10%	+25°C	18.5	20.3	22.5	mV
		PWM duty cycle 1%	+25°C	1.65	2.5	3.25	mV
		PWM duty cycle 0.2%	+25°C		0.92		mV
FB Pin Bias Current	I _{FB}	V _{FB} = 200mV	Full		0.001	0.3	μA
V _{REF} Filter Time Constant	t _{REF}		+25°C		0.1		ms
N-Channel MOSFET On-Resistance	R _{DS(ON)}		+25°C		0.5	0.8	Ω
Switching Frequency	f _{SW}		Full	0.9	1.2	1.45	MHz
Switching MOSFET Current Limit	I _{LIM}		+25°C	1.15	1.5	1.85	A
Output Voltage Over-Voltage Threshold	V _{OVP_SW}		Full	36	38	39.5	V
CONTROL							
CTRL Logic High Voltage	V _H		Full	1.5			V
CTRL Logic Low Voltage	V _L		Full			0.4	V
CTRL Pin Internal Pull-Down Resistor	R _{PD}		+25°C		600		kΩ
CTRL Logic Low Time to Shutdown	t _{SD}	CTRL high to low	+25°C	2.5			ms
PWM Dimming Frequency Range	DFR		+25°C	10		100	kHz
Minimum PWM On-Time			+25°C	40			ns
Stable Dimming Range	DR		+25°C	0.2		100	%
THERMAL SHUTDOWN							
Thermal Shutdown Threshold	T _{SHUTDOWN}				160		°C
Thermal Shutdown Hysteresis	T _{HYS}				20		°C

38V High Efficiency, Boost WLED Driver with PWM Control

SGM3752

RECOMMENDED COMPONENTS OF TEST CIRCUITS

	COMPONENT		COMPONENT
INDUCTOR	10 μ H/CD75NP-100KC	CAPACITOR	1 μ F/C2012X7R1H105KT
DIODE	MBR0540		22 μ F/C2012X7R1H226KT

TYPICAL PERFORMANCE CHARACTERISTICS

T_A = +25°C, L = 10 μ H, C_{IN} = 22 μ F, C_{OUT} = 1 μ F, unless otherwise noted.

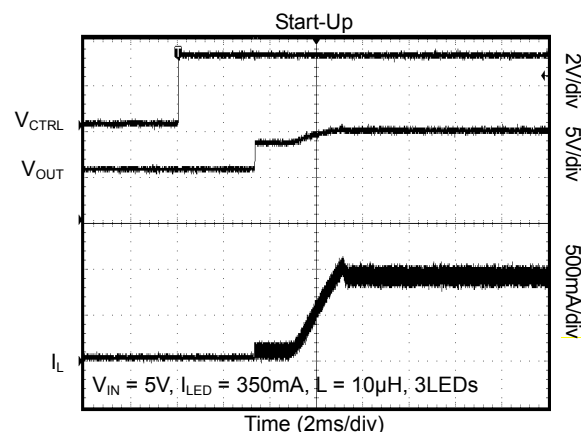
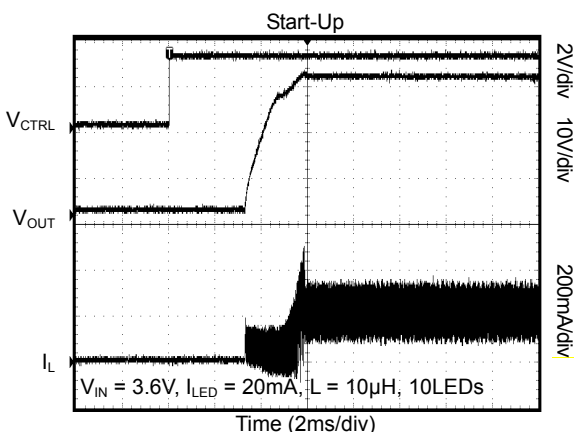
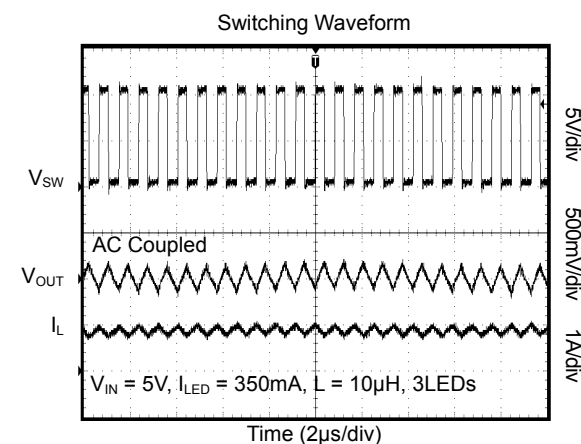
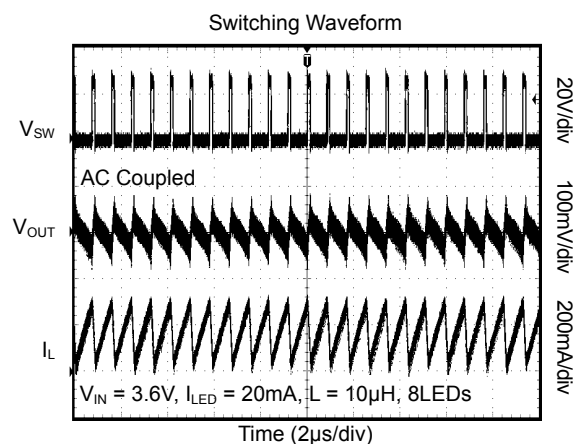
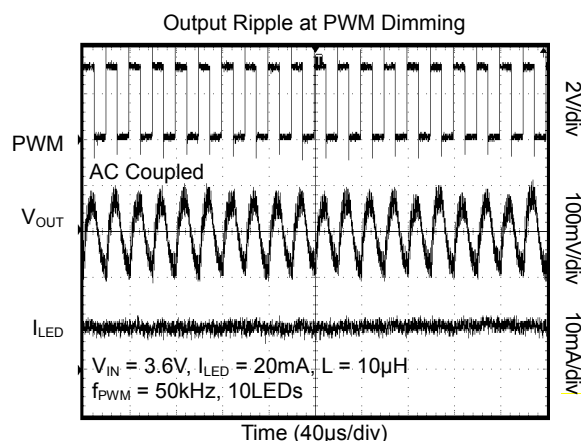
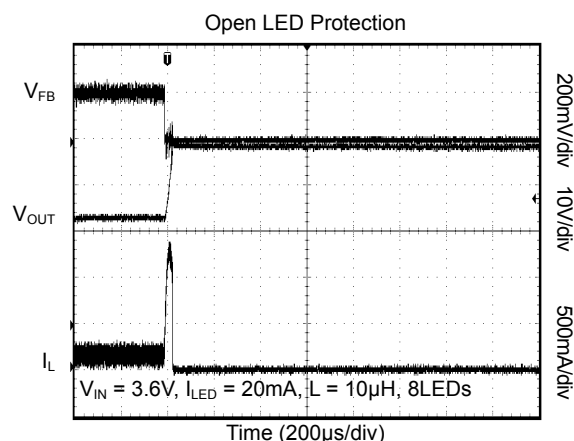

38V High Efficiency, Boost WLED Driver with PWM Control

SGM3752

TYPICAL PERFORMANCE CHARACTERISTICS (Continued)

$T_A = +25^\circ\text{C}$, $L = 10\mu\text{H}$, $C_{IN} = 22\mu\text{F}$, $C_{OUT} = 1\mu\text{F}$, unless otherwise noted.

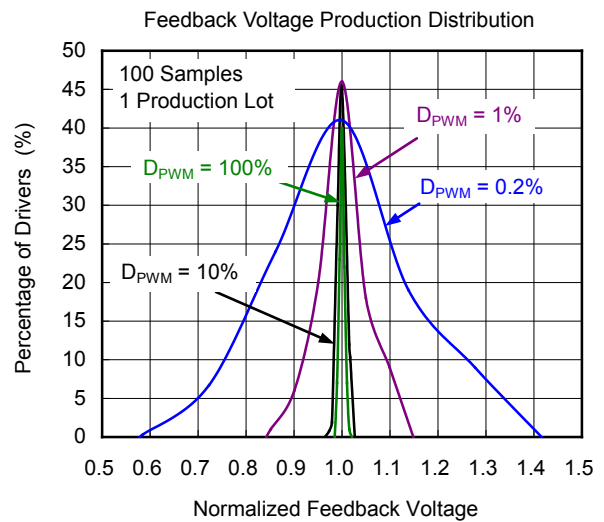
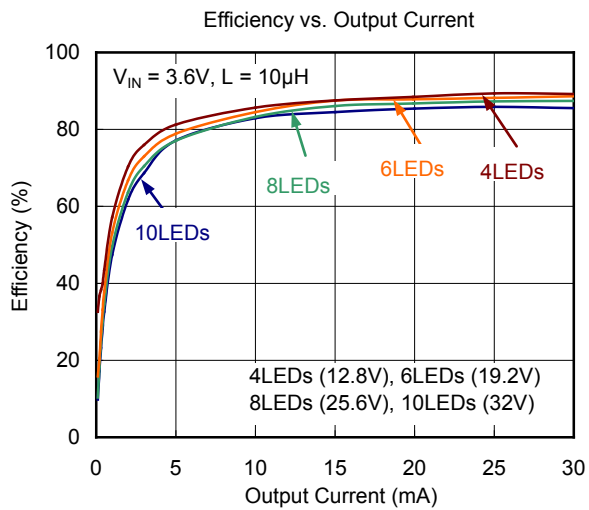
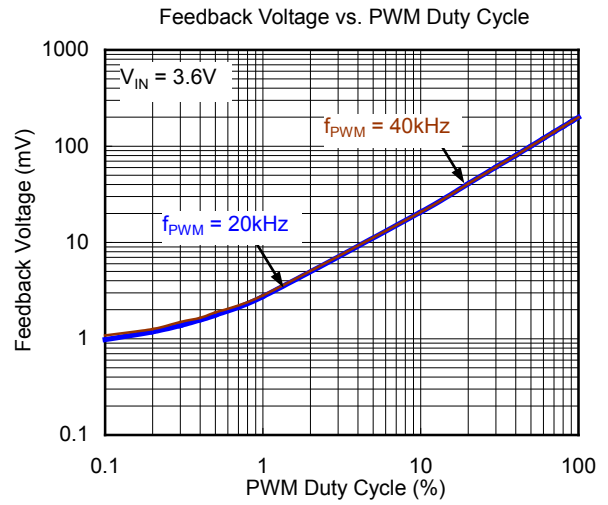
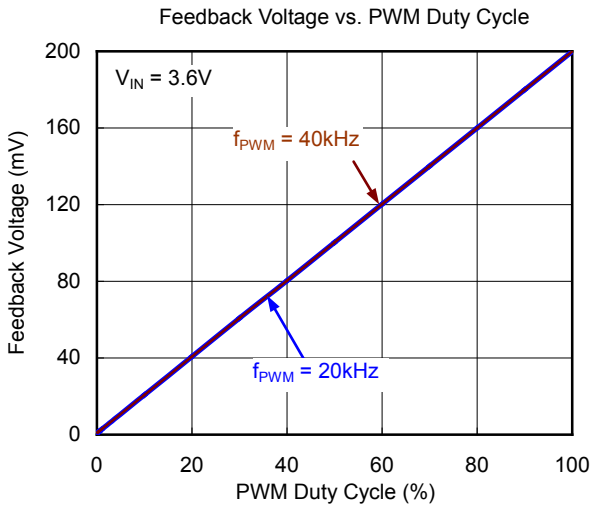

FUNCTIONAL BLOCK DIAGRAM

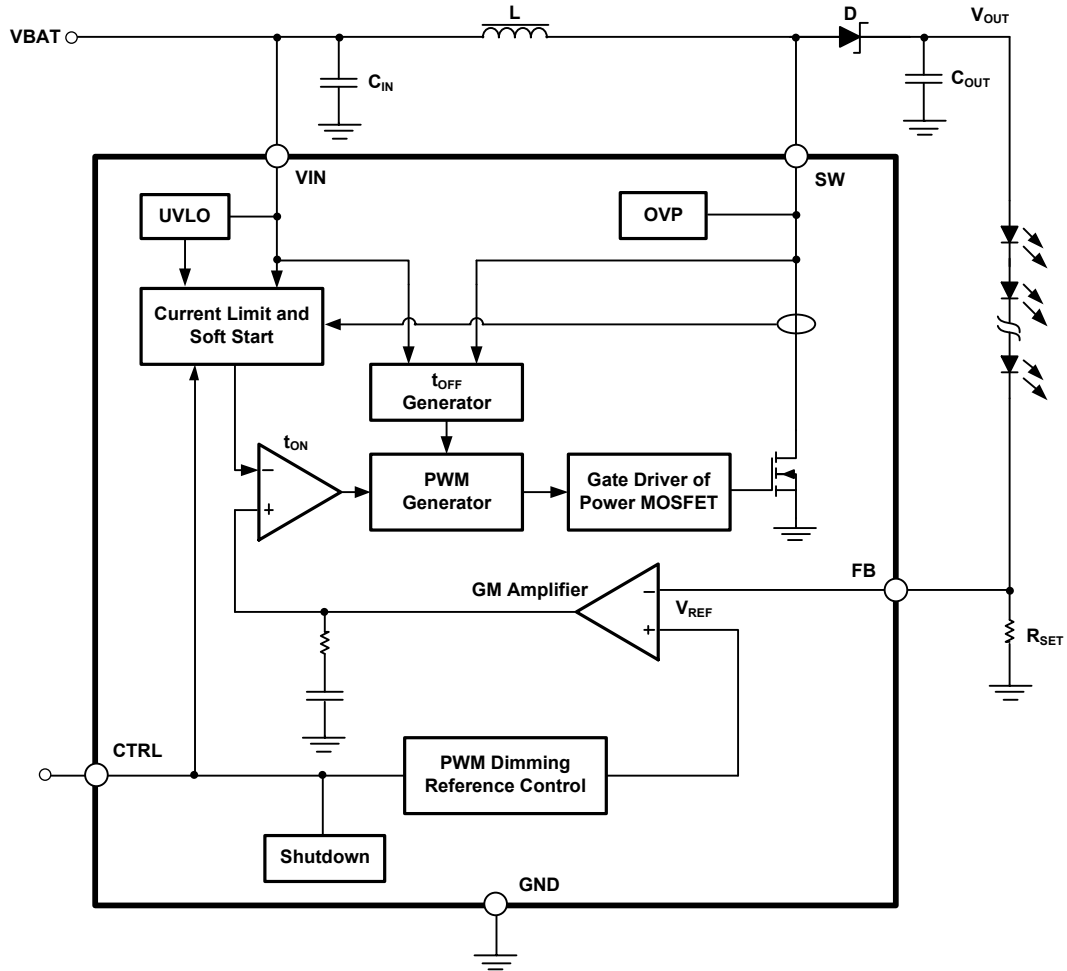

Figure 2. SGM3752 Block Diagram

DETAILED DESCRIPTION

The SGM3752 is a high efficiency, high output voltage boost converter in small package size. The device integrates 40V switch FET and is designed for output voltage up to 38V with a switch peak current limit of 1.5A. Its large driving capability can drive single or parallel LED strings for small to large size panel backlighting.

The SGM3752 operates in a current mode scheme with quasi-constant frequency. It is internally compensated for maximum flexibility and stability. The switching frequency is 1.2MHz, and the minimum input voltage is 2.7V. During the on-time, the current rises into the inductor. When the current reaches a threshold value set by the internal GM amplifier, the power switch MOSFET is turned off. The polarity of the inductor changes and forward biases the Schottky diode which lets the current flow towards the output of the boost converter.

The SGM3752 topology has also the benefits of providing very good load and line regulations, and excellent line and load transient responses.

The feedback loop regulates the FB pin to a low reference voltage (200mV typical), reducing the power dissipation in the current sense resistor.

Soft Start-Up

Soft-start circuitry is integrated into the IC to avoid high inrush current spike during start-up. After the device is enabled, the GM amplifier output voltage ramps up very slowly, which ensures that the output voltage rises slowly to ensure the smooth start-up and minimize the inrush current.

Open LED Protection

Open LED protection circuitry prevents IC damage as the result of white LED disconnection. The SGM3752 monitors the voltage at the SW pin during each switching cycle. The circuitry turns off the switch FET and shuts down the IC when the following condition persists for 8 switching cycles: the SW voltage exceeds the V_{OVP} threshold. As the result, the output voltage falls to the level of the input supply. The device remains in shutdown mode until it is enabled by toggling the CTRL pin.

Shutdown

The SGM3752 enters shutdown mode when the CTRL voltage is logic low for more than 2.5ms. Although the internal switch FET does not switch in shutdown, there is still a DC current path between the input and the LEDs through the inductor and Schottky diode. The minimum forward voltage of the LED array must exceed the maximum input voltage to ensure that the LEDs remain off in shutdown.

Current Program

The FB voltage is regulated by a low 200mV reference voltage. The LED current is programmed externally using a current-sense resistor in series with the LED string(s). The value of the R_{SET} is calculated using Equation 1:

$$I_{LED} = \frac{V_{FB}}{R_{SET}} \quad (1)$$

Where:

I_{LED} = total output current of LED string(s)

V_{FB} = regulated voltage of FB pin

R_{SET} = current sense resistor

The output current tolerance depends on the FB accuracy and the current sensor resistor accuracy.

DETAILED DESCRIPTION (Continued)

LED Brightness Dimming

The SGM3752 receives PWM dimming signal at CTRL pin to control the total output current. When the CTRL pin is constantly high, the FB voltage is regulated to 200mV typically. When the duty cycle of the input PWM signal is low, the regulation voltage at FB pin is reduced, and the total output current is reduced; therefore, it achieves LED brightness dimming. The relationship between the duty cycle and FB regulation voltage is given by Equation 2:

$$V_{FB} = \text{Duty} \times 200\text{mV} + 0.75\text{mV} \quad (2)$$

Where:

Duty = duty cycle of the PWM signal

200mV = internal reference voltage

0.75mV = most appreciate maximum from production statistics

Thus, the user can easily control the WLED brightness by controlling the duty cycle of the PWM signal. The PWM frequency is in the range from 10kHz to 100kHz, and the recommended minimum PWM duty cycle is 0.1% for no blind dimming.

As shown in

Figure 3, the IC chops up the internal 200mV reference voltage at the duty cycle of the PWM signal. The pulse signal is then filtered by an internal low pass filter. The output of the filter is connected to the GM amplifier as the reference voltage for the FB pin regulation. Therefore, although a PWM signal is used for brightness dimming, only the WLED DC current is modulated, which is often referred as analog dimming. This eliminates the audible noise which often occurs when the LED current is pulsed in replica of the frequency and duty cycle of PWM control. Unlike other methods which filter the PWM signal for analog dimming, SGM3752 regulation voltage is independent of the PWM logic voltage level which often has large variations.

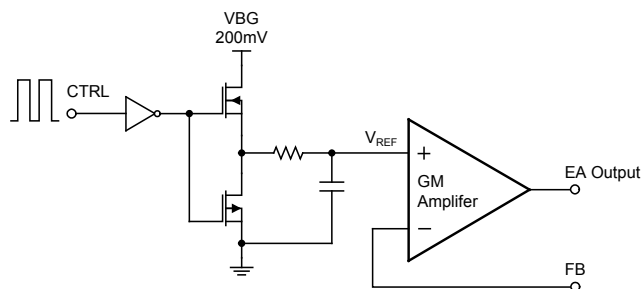

Figure 3. Programmable FB Voltage Using PWM Signal

Under-Voltage Lockout

An under-voltage lockout prevents operation of the device at input voltages below typical 2.2V. When the input voltage is below the under-voltage threshold, the device is shut down, and the internal switch FET is turned off. If the input voltage rises by under-voltage lockout hysteresis, the IC restarts.

Thermal Shutdown

If the typical junction temperature of 160 °C is exceeded, an internal thermal shutdown turns off the device. The device is released from shutdown automatically when the junction temperature decreases by 20°C.

Operation with CTRL

The enable rising edge threshold voltage is 1.5V and the falling edge threshold voltage is 0.4V. With the CTRL terminal is held below the falling edge threshold voltage the device is disabled and switching is inhibited. The IC quiescent current is reduced in this state. When input voltage is above the UVLO threshold, and the CTRL terminal voltage is increased above the rising edge threshold, the device becomes active. Switching enables and the soft-start sequence initiates.

APPLICATION INFORMATION

The SGM3752 device is a step-up DC-DC converter which can drive single or parallel LED strings for small to large size panel backlighting.

Design Requirements

For this design example, use the parameters listed in Table 1 as the input parameters.

Table 1. Design Parameters

DESIGN PARAMETER	EXAMPLE VALUE
Input Voltage Range	2.7V to 5.5V
Output, LED Number in A String	10
Output, LED String Number	1
Output, LED Current per String	20mA

Inductor Selection

The selection of the inductor affects power efficiency, steady state operation as well as transient behavior and loop stability. These factors make it the most important component in power regulator design. There are three important inductor specifications, inductor value, DC resistance and saturation current. Considering inductor value alone is not enough. The inductor value determines the inductor ripple current. Choose an inductor that can handle the necessary peak current without saturating. Follow Equation 3 to Equation 4 to calculate the inductor's peak current. To calculate the current in the worst case, use the minimum input voltage, maximum output voltage and maximum load current of application. In a boost regulator, the input DC current can be calculated as Equation 3.

$$I_{L(DC)} = \frac{V_{OUT} \times I_{OUT}}{V_{IN} \times \eta} \quad (3)$$

Where:

V_{OUT} = boost output voltage

I_{OUT} = boost output current

V_{IN} = boost input voltage

η = power conversion efficiency

The inductor current peak-to-peak ripple can be calculated as Equation 4.

$$\Delta I_{L(P-P)} = \frac{1}{L \times \left(\frac{1}{V_{OUT} - V_{IN}} + \frac{1}{V_{IN}} \right) \times f_s} \quad (4)$$

Where:

$\Delta I_{L(P-P)}$ = inductor peak-to-peak ripple

L = inductor value

f_s = boost switching frequency

V_{OUT} = boost output voltage

V_{IN} = boost input voltage

Therefore, the peak current $I_{L(P)}$ seen by the inductor is calculated with Equation 5.

$$I_{L(P)} = I_{L(DC)} + \frac{\Delta I_{L(P-P)}}{2} \quad (5)$$

Inductor values can have $\pm 20\%$ tolerance with no current bias. When the inductor current approaches saturation level, its inductance can decrease 20% to 35% from the 0A value depending on how the inductor vendor defines saturation current. Using an inductor with a smaller inductance value forces discontinuous PWM when the inductor current ramps down to zero before the end of each switching cycle. This reduces the boost converter's maximum output current, causes large input voltage ripple and reduces efficiency. Large inductance value provides much more output current and higher conversion efficiency. For these reasons, a 4.7 μ H to 10 μ H inductor value range is recommended, and 4.7 μ H inductor is recommended for higher than 5V input voltage by considering inductor peak current and loop stability.

Schottky Diode Selection

The SGM3752 demands a low forward voltage, high-speed and low capacitance Schottky diode for optimum efficiency. Ensure that the diode average and peak current rating exceeds the average output current and peak inductor current. In addition, the diode reverse breakdown voltage must exceed the open LED protection voltage. ONSem NSR0240 is recommended for the SGM3752.

APPLICATION INFORMATION (Continued)

Output Capacitor Selection

The output capacitor is mainly selected to meet the requirement for the output ripple and loop stability. This ripple voltage is related to capacitor capacitance and its equivalent series resistance (ESR). Assuming a capacitor with zero ESR, the minimum capacitance needed for a given ripple can be calculated with Equation 6:

$$C_{OUT} = \frac{(V_{OUT} - V_{IN}) \times I_{OUT}}{V_{OUT} \times f_S \times V_{RIPPLE}} \quad (6)$$

Where:

V_{RIPPLE} = peak-to-peak output ripple

The additional part of the ripple caused by ESR is calculated using: $V_{RIPPLE_ESR} = I_{OUT} \times R_{ESR}$.

Due to its low ESR, V_{RIPPLE_ESR} could be neglected for ceramic capacitors, a $1\mu\text{F}$ to $10\mu\text{F}$ capacitor is recommended for typical application.

A $1\mu\text{F}$ output capacitor is suggested for 10/8/6-Series LED applications. For high output current applications like 3S8P, larger value output capacitors of $2.2\mu\text{F}$ is recommended to minimize the output ripple.

LED Current Set Resistor

The LED current set resistor can be calculated by Equation 1.

Thermal Considerations

The allowable IC junction temperature should be considered under normal operating conditions. This restriction limits the power dissipation of the SGM3752. The allowable power dissipation for the device can be determined by Equation 7:

$$P_D = \frac{150^\circ\text{C} - T_A}{\theta_{JA}} \quad (7)$$

Where:

T_A is the ambient temperature for the application.

θ_{JA} is the thermal resistance junction-to-ambient given in Power Dissipation Table.

Power Supply Recommendations

The device is designed to operate from an input voltage supply range between 2.7V and 5.5V. This input supply must be well regulated. If the input supply is located more than a few inches from the SGM3752 device, additional bulk capacitance may be required in addition to the ceramic bypass capacitors.

EMI Precaution and Ringing Cancelling

Careful layout, routing and selection of decoupling components are equal keys to successfully putting a high energy transmission swing boost backlight driver together with a waveform sensitive communication transceiver into a condensed case. Engineering test on cellular phones indicates, with shielding case's separation and isolation, that conducting propagation along with power supply trace contributes the most comparing with the other EMI mechanisms, the coupling and the radiation, even being evaluated with radiation measurement oriented FCC Part 15 Class-B method. The typical EMI evaluation to narrow band transmitter is ACLR masking, and TX power limit to wide band transmitter and RX sensitivity to either narrow band or wide band, which are powers needed to obtain given bit error rate.

Ways of conducting EMI suppression include propagation limit and reduction of energy swings, such as inserting absorbing ferrite bead in power supply trace, selecting high self-resonance frequency decoupling capacitors and ringing cancellation. Figure 4 is a simplified circuit showing that ringing is relaxation oscillation between diode junction capacitance C_j and boost inductor L , which injects current swings into power supply trace; the 2 voltage waveforms illustrate the difference of circuit performance, with or without ringing cancellation.

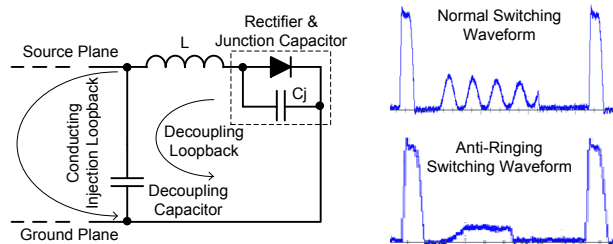

Figure 4. Ringing Cancellation Illustration

APPLICATION INFORMATION (Continued)

Layout Considerations

As for all switching power supplies, especially those high frequency and high current ones, layout is an important design step. If layout is not carefully done, the regulator could suffer from instability as well as noise problems. Therefore, use wide and short traces for high current paths. The input capacitor C_{IN} needs to be close to VIN pin and GND pin in order to reduce the input ripple seen by the IC. If possible choose higher capacitance value for it. The SW pin carries high current with fast rising and falling edge, therefore, the connection between the SW pin to the inductor should

be kept as short and wide as possible. The output capacitor C_{OUT} should be put close to VOUT. It is also beneficial to have the ground of C_{OUT} close to the GND pin since there is large ground return current flowing between them. FB resistor should be put close to FB pin. When laying out signal ground, it is recommended to use short traces separated from power ground traces, and connect them together at a single point close to the GND pin.

PACKAGE INFORMATION

PACKAGE OUTLINE DIMENSIONS

TSOT-23-6

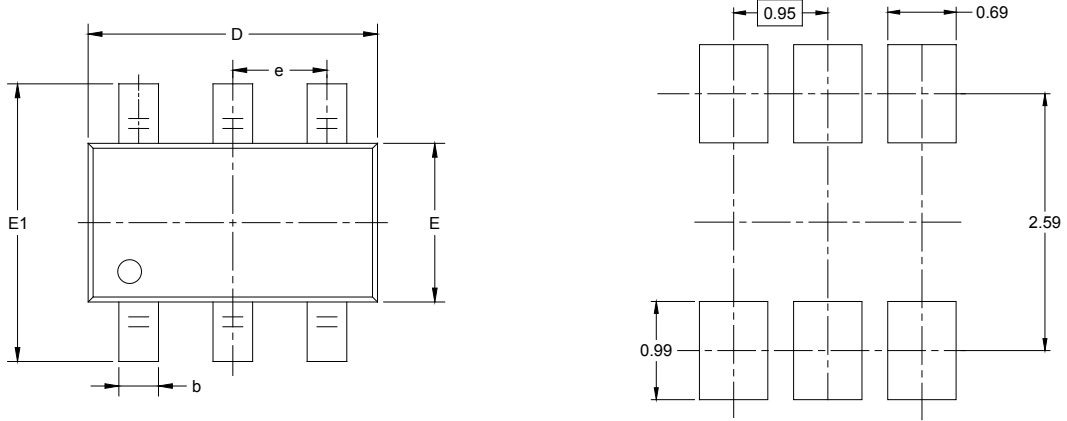

RECOMMENDED LAND PATTERN (Unit: mm)

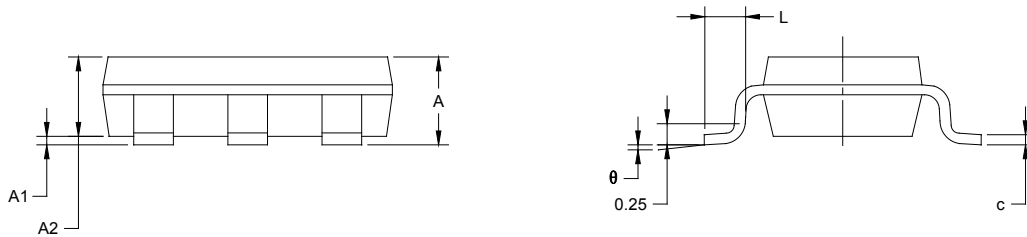

Symbol	Dimensions In Millimeters		Dimensions In Inches	
	MIN	MAX	MIN	MAX
A		1.000		0.043
A1	0.000	0.100	0.000	0.004
A2	0.700	0.900	0.028	0.039
b	0.300	0.500	0.012	0.020
c	0.080	0.200	0.003	0.008
D	2.850	2.950	0.112	0.116
E	1.550	1.650	0.061	0.065
E1	2.650	2.950	0.104	0.116
e	0.950 BSC		0.037 BSC	
L	0.300	0.600	0.012	0.024
θ	0°	8°	0°	8°

TAPE AND REEL INFORMATION

REEL DIMENSIONS

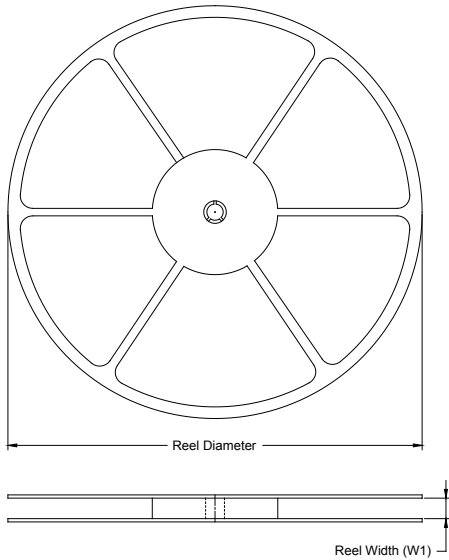

TAPE DIMENSIONS

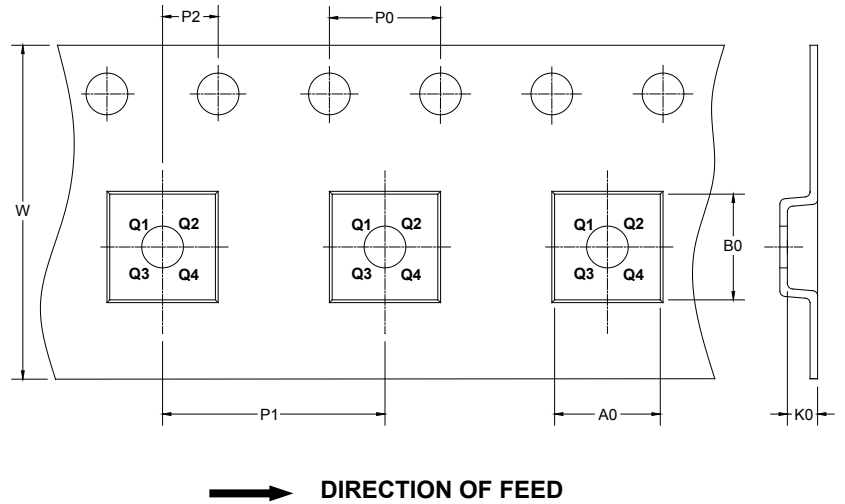

NOTE: The picture is only for reference. Please make the object as the standard.

KEY PARAMETER LIST OF TAPE AND REEL

Package Type	Reel Diameter	Reel Width W1 (mm)	A0 (mm)	B0 (mm)	K0 (mm)	P0 (mm)	P1 (mm)	P2 (mm)	W (mm)	Pin1 Quadrant
TSOT-23-6	7"	9.5	3.2	3.1	1.1	4.0	4.0	2.0	8.0	Q3

DD0001

PACKAGE INFORMATION

CARTON BOX DIMENSIONS

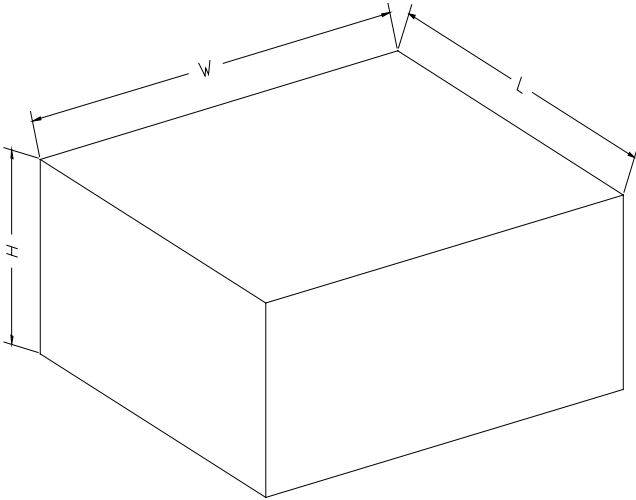

NOTE: The picture is only for reference. Please make the object as the standard.

KEY PARAMETER LIST OF CARTON BOX

Reel Type	Length (mm)	Width (mm)	Height (mm)	Pizza/Carton
7" (Option)	368	227	224	8
7"	442	410	224	18

DD0002