



SGM3741

High Efficiency, 3-Channel, 38V Step-Up WLED Driver

GENERAL DESCRIPTION

The SGM3741 is a 3-Channel step-up DC/DC converter designed for driving the white LEDs with an internal 25mA constant current per channel. This device features integrated, 38V power MOSFETs that is capable of driving up to 10 white LEDs per channel, providing inherent current matching for uniform brightness. The SGM3741 supports two PWM signals to control the backlight brightness. The PWM frequency is in the range from 2kHz to 60kHz to avoid audible noise from inductor or ceramic capacitor, combining the two PWM to get very wide brightness dimming range. PWM pin is always used for Content Adaptive Brightness Control (CABC) schemes. Constant 600kHz switching frequency is used in SGM3741.

The SGM3741 features a variety of protection circuits, including integrated 38.5V over-voltage protection (OVP), soft-start, cycle-by-cycle current limiting, and thermal shutdown protection circuitry.

SGM3741 supports 3V to 18V input voltage, and then SGM3741 can be used in one cell or two-cell battery equipments.

The SGM3741 has 2.2A current limit. It is available in Green TQFN-3×3-16L package. It operates over an ambient temperature range of -40°C to +85°C.

FEATURES

- High-Efficiency Boost DC/DC WLED Bias Supply
- Internal 38V, 0.25Ω Power MOSFET
- 3V to 18V Input Voltage Range
- 600kHz Constant Switching Frequency
- Up to 10 Serial White LEDs per Channel
- 25mA Constant Current per Channel
- Switch Current Limit: 2.2A
- Dual PWM Dimming Scheme for Large Dimming Range
- 2kHz to 60kHz PWM Dimming Frequency
- Internal 1MΩ Pull-Down Resistor at CTRL Pin
- Internal 500kΩ Pull-Up Resistor at PWM Pin
- Internal 38.5V Over-Voltage Protection
- Cycle-by-Cycle Over-Current Protection
- Soft-Start Function
- No Leakage from V_{IN} to GND through LED String
- Thermal Shutdown
- -40°C to +85°C Operating Temperature Range
- Available in Green TQFN-3×3-16L Package

APPLICATIONS

TFT LCD Displays
Smart Phones

SGM3741

PACKAGE/ORDERING INFORMATION

MODEL	PACKAGE DESCRIPTION	SPECIFIED TEMPERATURE RANGE	ORDERING NUMBER	PACKAGE MARKING	PACKING OPTION
SGM3741	TQFN-3x3-16L	-40°C to +85°C	SGM3741YTQ16G/TR	3741TQ XXXXX	Tape and Reel, 4000

NOTE: XXXXXX = Date Code and Vendor Code.

Green (RoHS & HSF): SG Micro Corp defines "Green" to mean Pb-Free (RoHS compatible) and free of halogen substances. If you have additional comments or questions, please contact your SGMICRO representative directly.

ABSOLUTE MAXIMUM RATINGS

SW, VOUT, CH1, CH2, CH3 to GND.....-0.3V to 40V
 VIN to GND.....-0.3V to 20V
 CTRL, PWM to GND.....-0.3V to 6V
 Continuous SW Current..... Internally limited to 1.65A
 Operating Temperature Range..... -40°C to +85°C
 Storage Temperature Range..... -65°C to +150°C
 Junction Temperature..... 150°C
 Lead Temperature (Soldering 10 sec).....260°C
 ESD Susceptibility
 HBM.....2000V
 MM..... 200V

OVERSTRESS CAUTION

Stresses beyond those listed may cause permanent damage to the device. Functional operation of the device at these or any other conditions beyond those indicated in the operational section of the specification is not implied. Exposure to absolute maximum rating conditions for extended periods may affect reliability.

ESD SENSITIVITY CAUTION

This integrated circuit can be damaged by ESD if you don't pay attention to ESD protection. SGMICRO recommends that all integrated circuits be handled with appropriate precautions. Failure to observe proper handling and installation procedures can cause damage. ESD damage can range from subtle performance degradation to complete device failure. Precision integrated circuits may be more susceptible to damage because very small parametric changes could cause the device not to meet its published specifications.

DISCLAIMER

SG Micro Corp reserves the right to make any change in circuit design, specification or other related things if necessary without notice at any time.

PIN CONFIGURATION

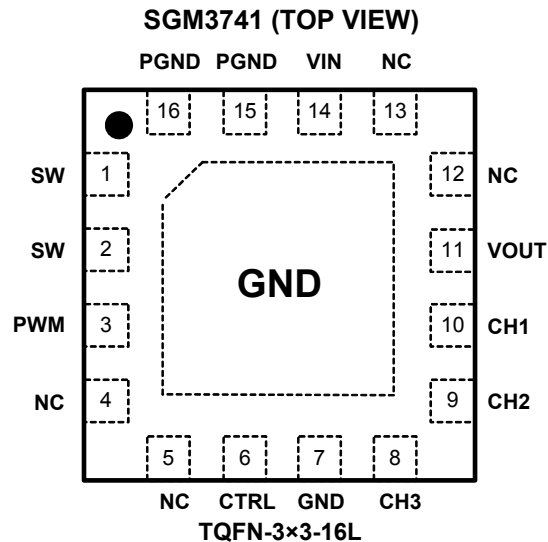

PIN DESCRIPTION

PIN	NAME	FUNCTION
1, 2	SW	Switch Output. Connect this pin to the inductor and the Schottky diode.
3	PWM	Pulse Width Controlled Dimming Input. Connect this pin to logic "High" or floating when not used.
4, 5, 12, 13	NC	No Connection.
6	CTRL	IC Enable and Pulse Width Controlled Dimming Input.
7	GND	Ground.
8	CH3	LED String 3 Current Input. Connect the LED String 3 cathode to this pin.
9	CH2	LED String 2 Current Input. Connect the LED String 2 cathode to this pin.
10	CH1	LED String 1 Current Input. Connect the LED String 1 cathode to this pin.
11	VOUT	Output Voltage Pin.
14	VIN	Input Supply Pin.
15, 16	PGND	Power Ground Pin.
Exposed Pad	GND	Exposed pad should be soldered to PCB board and connected to GND.

ELECTRICAL CHARACTERISTICS

($V_{IN} = 3.6V$, $V_{CTRL} = V_{PWM} = 3V$, $L = 10\mu H$, $C_{IN} = 22\mu F$, $C_{OUT} = 1\mu F$, Full = $-40^{\circ}C$ to $+85^{\circ}C$, typical values are at $T_A = 25^{\circ}C$, unless otherwise specified.)

PARAMETER	SYMBOL	CONDITIONS	TEMP	MIN	TYP	MAX	UNITS
Input Voltage	V_{IN}		Full	3		18	V
Power Switch Voltage Rating			Full			38	V
Switch Frequency			Full	480	600	700	kHz
Under-Voltage Lockout Threshold	V_{UVLO}	V_{IN} Rising	$+25^{\circ}C$		2.3	2.5	V
Under-Voltage Lockout Hysteresis			$+25^{\circ}C$		90		mV
Supply Current		Not Switching	$+25^{\circ}C$		0.24		mA
		Switching	$+25^{\circ}C$		0.8		mA
Supply Current in Shutdown	I_{SHDN}	CTRL = GND, $V_{IN} = 3.6V$	$+25^{\circ}C$		0.4	1	μA
Switch Current Limit	I_{LIM}		$+25^{\circ}C$	1.68	2.20	2.80	A
Switch On Resistance	$R_{DS(ON)}$	$V_{IN} = 3.6V$	$+25^{\circ}C$		0.25	0.39	Ω
Switch Leakage Current		$V_{SW} = 35V$, CTRL = GND	$+25^{\circ}C$		0.1	1	μA
Internal LED Current per Channel			$+25^{\circ}C$	23.7	25	25.9	mA
LED Current Matching		$I_{LED} = 25mA$	$+25^{\circ}C$	-1.3		1.3	%
Over-Voltage Protection Threshold		Measured at VOUT pin	Full	37.0	38.5	40.0	V
Thermal Shutdown Temperature					145		$^{\circ}C$
Thermal Shutdown Hysteresis					15		$^{\circ}C$
CONTROL							
CTRL, PWM Threshold	Logic-High Voltage	V_{IH}	$V_{IN} = 3V$ to $18V$	Full	1.5		V
	Logic-Low Voltage	V_{IL}	$V_{IN} = 3V$ to $18V$	Full		0.4	V
Pull-Down Resistor		$R_{PULL-DOWN}$	$+25^{\circ}C$		1		M Ω
Pull-Up Resistor		$R_{PULL-UP}$	$+25^{\circ}C$		0.5		M Ω
CTRL Pin Logic High Pulse Width Timing		$t_{HIGH(MIN)}$	$+25^{\circ}C$	0.4			μs
CTRL Pin Logic Low Pulse Width Timing		t_{LOW}	$+25^{\circ}C$	0.4		1000	μs
CTRL Pin Shutdown Pulse Width Timing		t_{OFF}	$+25^{\circ}C$	5.5			ms
Minimum PWM On-Time			$+25^{\circ}C$	0.08			μs
PWM Dimming Frequency			Full	2		60	kHz
PWM Dimming Duty Cycle ⁽¹⁾		CTRL = HIGH	$+25^{\circ}C$	0.5			%

NOTE:

1. If CTRL pin PWM dimming is also used, the minimum PWM duty cycle for no blind dimming is decided by the following conditions: the minimum LED current dimmed by two PWM is 0.5% of the internal LED current per channel.

TYPICAL PERFORMANCE CHARACTERISTICS

$V_{IN} = 3.6V$, $I_{LED} = 25mA$, 6-Series 3-Parallel LEDs, $L = 22\mu H$, $C_{IN} = 10\mu F$, $C_{OUT} = 1\mu F$, $T_A = +25^\circ C$, unless otherwise noted.

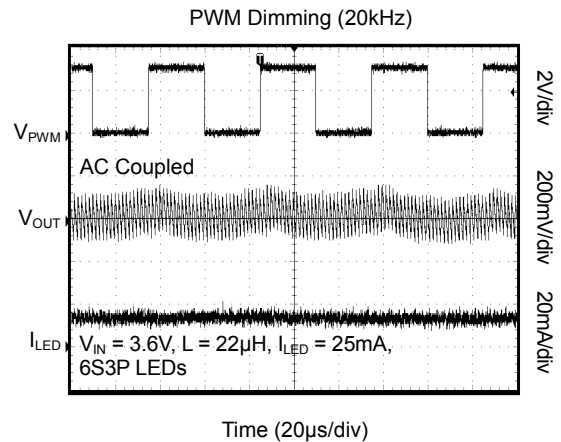
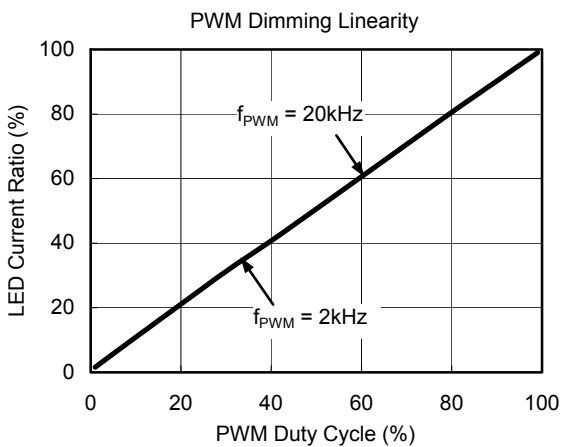
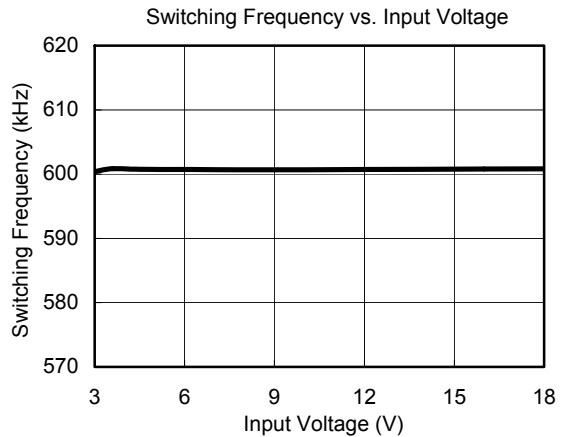
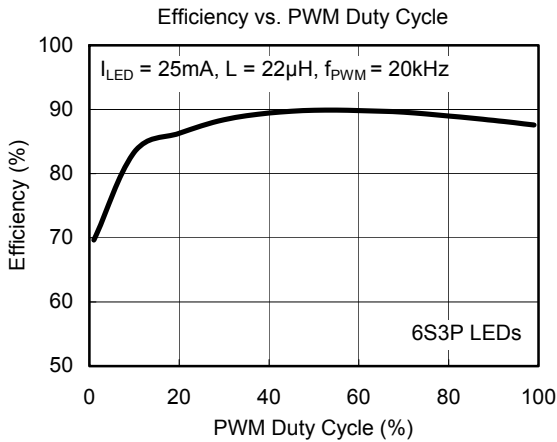
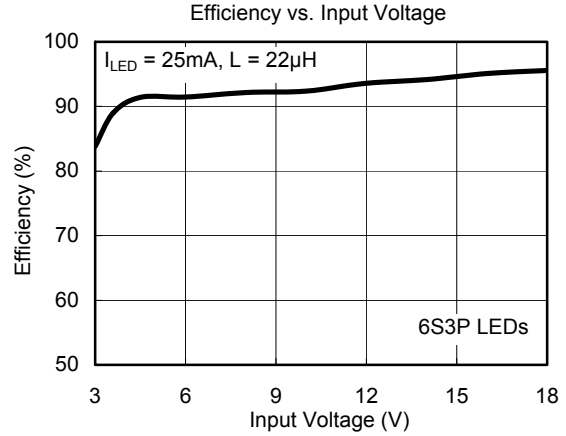
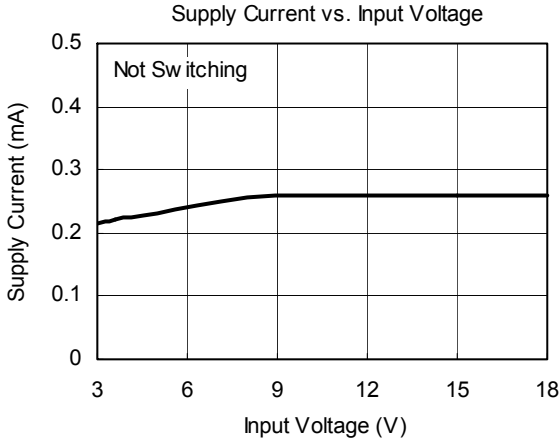

TYPICAL PERFORMANCE CHARACTERISTICS

$V_{IN} = 3.6V$, $I_{LED} = 25mA$, 6-Series 3-Parallel LEDs, $L = 22\mu H$, $C_{IN} = 10\mu F$, $C_{OUT} = 1\mu F$, $T_A = +25^\circ C$, unless otherwise noted.

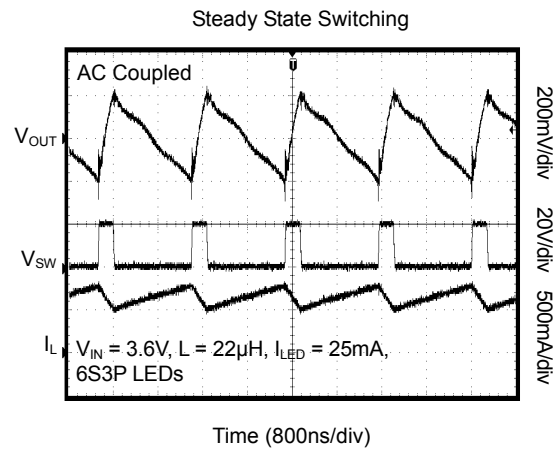
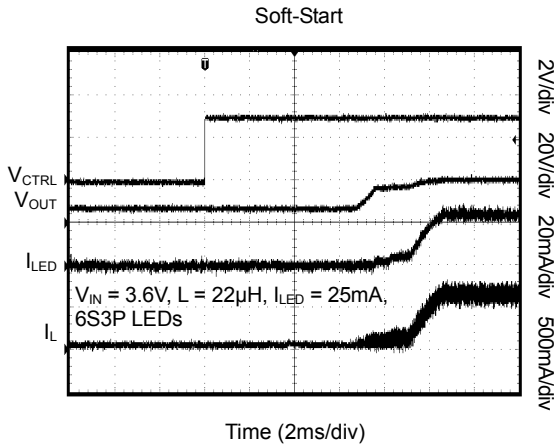

SGM3741

TYPICAL APPLICATION

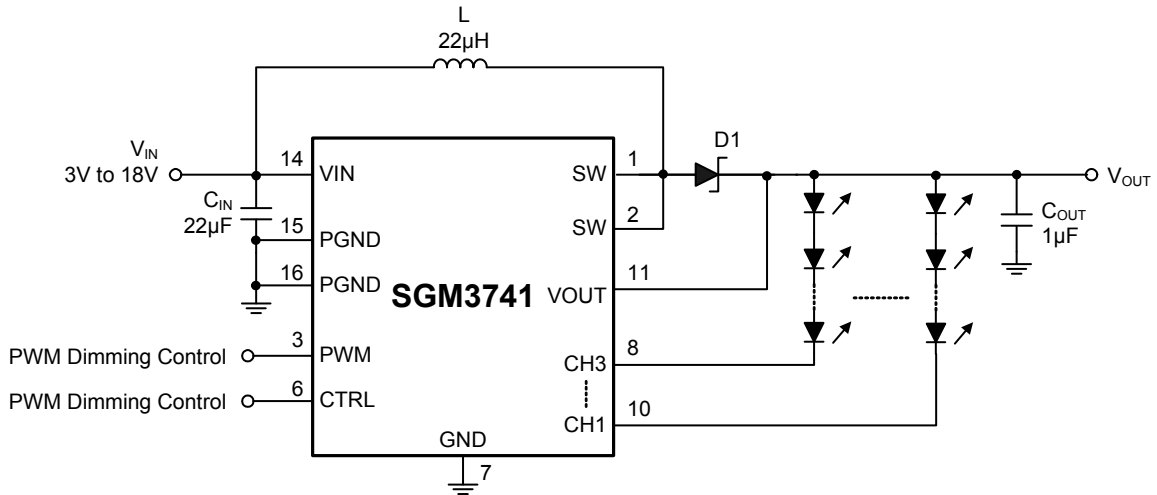

FUNCTIONAL BLOCK DIAGRAM

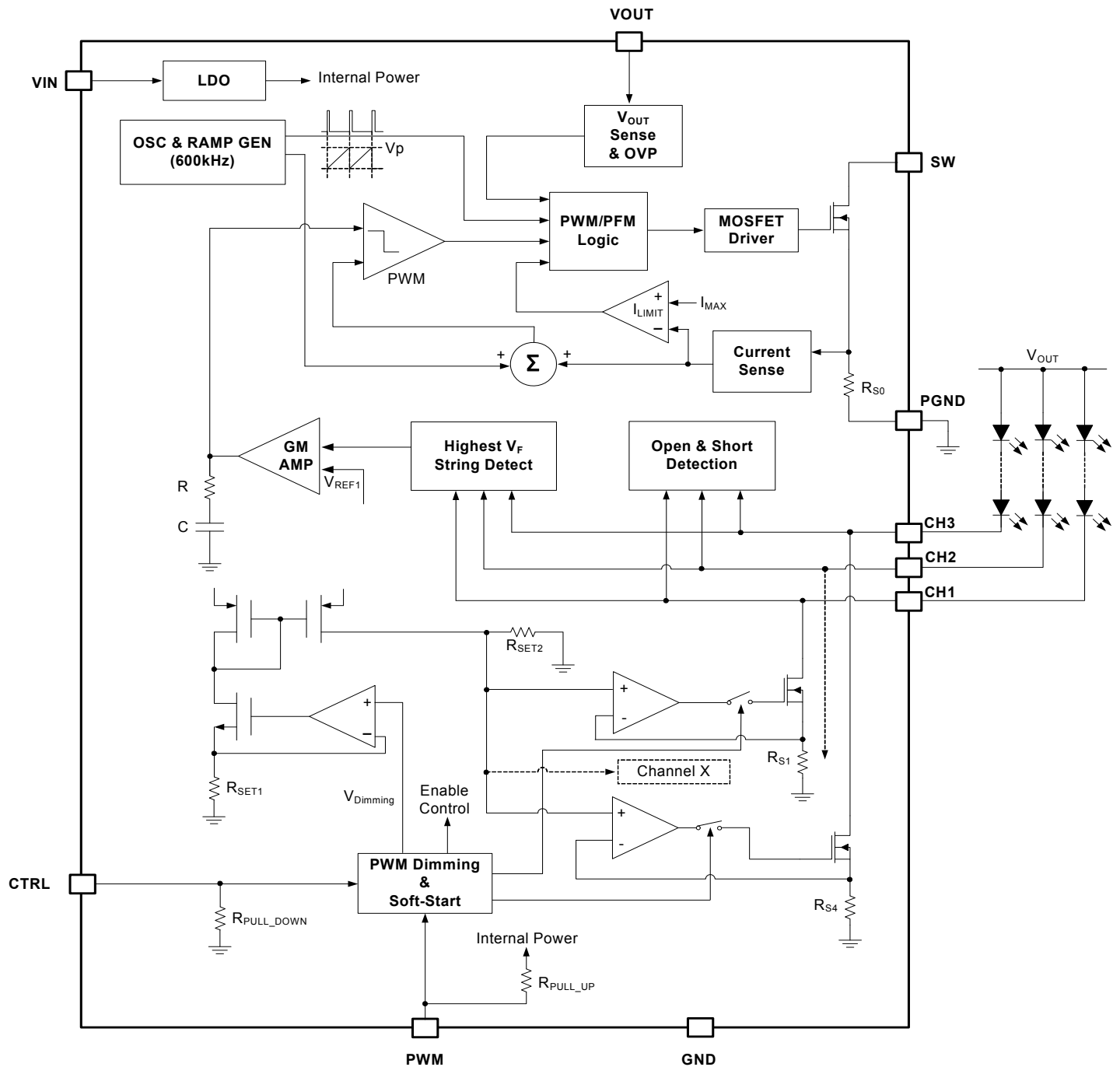

APPLICATION INFORMATION

Inductor Selection

The SGM3741 was designed for operation with inductors in the 10µH to 22µH range. Keep in mind that larger-valued inductors (usually requiring higher V_{IN}) generally yield higher efficiency due to lower switching frequency, while smaller inductors typically yield a smaller footprint but at the cost of lower efficiency. For best results, choose an inductor with a low DC-Resistance (DCR) and be sure to choose an inductor with a saturation current that exceeds the current limit 2.2A.

Diode Selection

The SGM3741 requires a Schottky diode as the rectifier. Select a low forward voltage drop Schottky diode with forward current (I_F) rating that exceeds the peak current limit 2.2A and a peak repetitive reverse voltage (V_{RRM}) rating that exceeds the maximum output voltage, typically set by the OVP threshold.

Capacitor Selection

The SGM3741 only requires a tiny 1µF output capacitor for most applications. For better output voltage filtering, a low ESR output capacitor is recommended. The selection of the output capacitor value directly influences the output voltage ripple of the converter which also influences line regulation.

An input capacitor in the range of 1µF to 22µF is suggested for 10/8/6 series LED applications.

Ceramic capacitors are recommended for most applications. For best performance, use X5R and X7R type ceramic capacitors, which possess less degradation in capacitance over voltage and temperature.

Shutdown

The SGM3741 features low-current shutdown mode. In shutdown mode, the control circuitry is disabled, the LEDs are disconnected and the quiescent supply current drops to less than 1µA. To disable the SGM3741, simply drive CTRL pin logic “low” for more than 5.5ms. To enable the ICs, drive CTRL pin to a logic “high”.

CHx Pin Unused

A user can easily disable the unused channel by connecting its CHx pin to VOUT pin.

PWM Brightness Dimming

The SGM3741 supports direct PWM dimming control, allowing LED current to be adjusted via a PWM signal. The LED current is proportional with the PWM duty cycle. For best results, using PWM frequencies in the 2kHz to 60kHz range to adjust LED current.

When the PWM pin is constantly high, the control voltage is regulated to V_{BG} typically, V_{BG} is programmed by CTRL PWM interface. The PWM pin allows a PWM signal to reduce this regulation voltage; therefore, it achieves LED brightness dimming. The relationship between the duty cycle and dimming voltage is given by Equation 1:

$$V_{DIMMING} = \text{Duty} \times V_{BG} \quad (1)$$

Where:

Duty = duty cycle of the PWM signal

V_{BG} is the internal reference voltage controlled by CTRL PWM interface

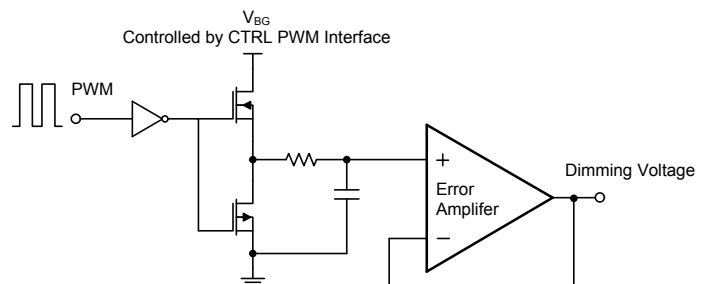

Figure 1. Block Diagram of PWM Dimming

APPLICATION INFORMATION

As shown in Figure 1, the IC chops up the internal V_{BG} reference voltage at the duty cycle of the PWM signal. The pulse signal is then filtered by an internal low pass filter. The output of the filter is connected to the error amplifier as the reference voltage to control output current. Therefore, although a PWM signal is used for brightness dimming, only the WLED DC current is modulated, which is often referred as analog dimming. This eliminates the audible noise which often occurs when the LED current is pulsed in replica of the frequency and duty cycle of PWM control. Unlike other scheme which filters the PWM signal for analog dimming, SGM3741 regulation voltage is independent of the PWM logic voltage level which often has large variations.

SGM3741 allows maximum flexibility with a PWM signal control input which can be used for dimming. The IC must remain enabled at CTRL pin during PWM dimming, which

means the step-up converter is active to reduce the response time. For the widest range of control, serial interface programming at CTRL pin can be used in conjunction with PWM dimming.

Low Input Voltage Application

In applications that have low input voltage range, such as those powered from 2-3 AA cells, the SGM3741 may still be used if there is a suitable system supply (such as 3.3V) available to power the controller. In such an application, the inductor may be connected directly to the battery, while the IC power is supplied by the system supply.

PACKAGE INFORMATION

PACKAGE OUTLINE DIMENSIONS

TQFN-3x3-16L

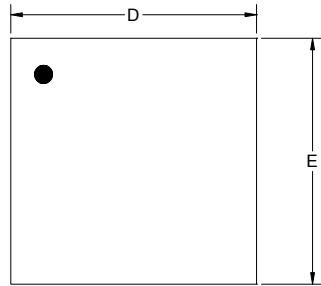

TOP VIEW

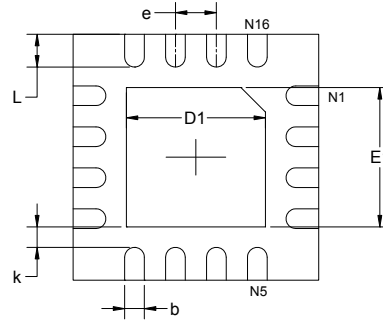

BOTTOM VIEW

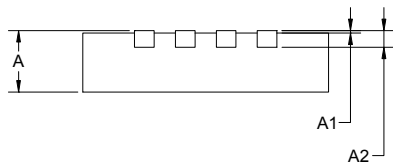

SIDE VIEW

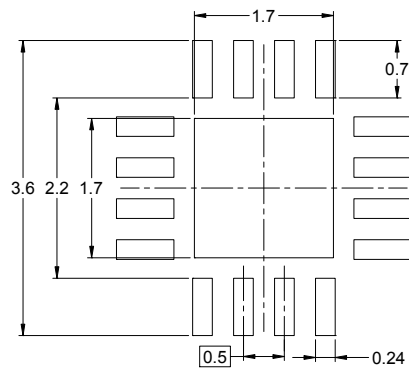

RECOMMENDED LAND PATTERN (Unit: mm)

Symbol	Dimensions In Millimeters		Dimensions In Inches	
	MIN	MAX	MIN	MAX
A	0.700	0.800	0.028	0.031
A1	0.000	0.050	0.000	0.002
A2	0.203 REF		0.008 REF	
D	2.900	3.100	0.114	0.122
D1	1.600	1.800	0.063	0.071
E	2.900	3.100	0.114	0.122
E1	1.600	1.800	0.063	0.071
k	0.200 MIN		0.008 MIN	
b	0.180	0.300	0.007	0.012
e	0.500 TYP		0.020 TYP	
L	0.300	0.500	0.012	0.020

TAPE AND REEL INFORMATION

REEL DIMENSIONS

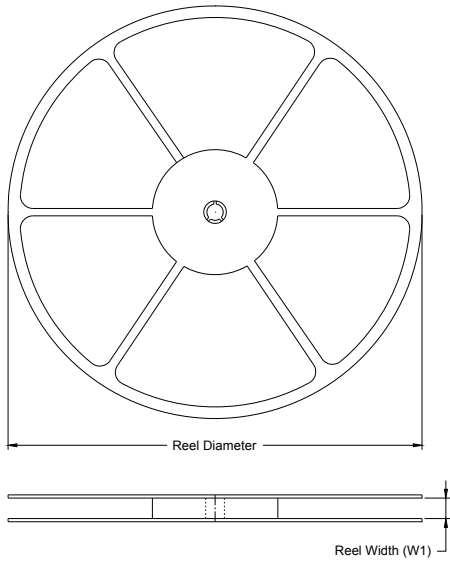

TAPE DIMENSIONS

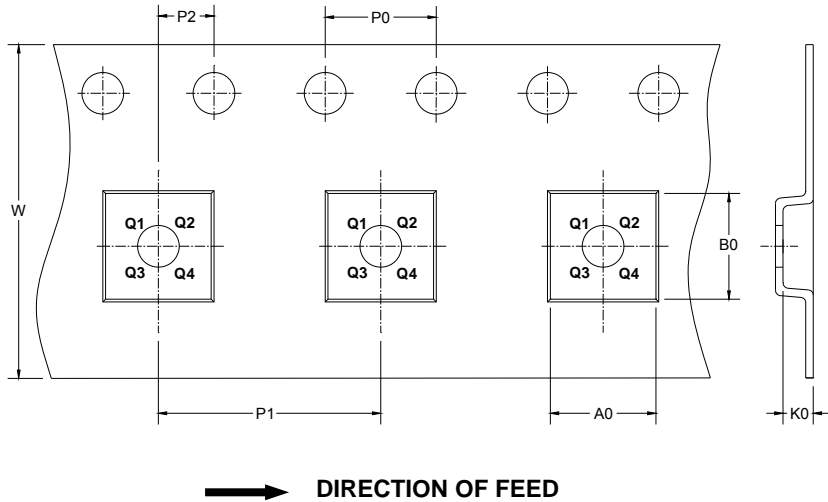

NOTE: The picture is only for reference. Please make the object as the standard.

KEY PARAMETER LIST OF TAPE AND REEL

Package Type	Reel Diameter	Reel Width W1 (mm)	A0 (mm)	B0 (mm)	K0 (mm)	P0 (mm)	P1 (mm)	P2 (mm)	W (mm)	Pin1 Quadrant
TQFN-3×3-16L	13"	12.40	3.35	3.35	1.13	4.00	4.00	2.00	12.00	Q1

DD0001

PACKAGE INFORMATION

CARTON BOX DIMENSIONS

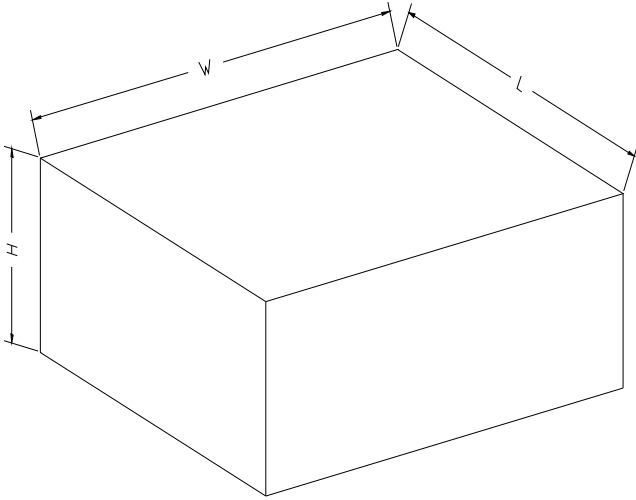

NOTE: The picture is only for reference. Please make the object as the standard.

KEY PARAMETER LIST OF CARTON BOX

Reel Type	Length (mm)	Width (mm)	Height (mm)	Pizza/Carton
13"	386	280	370	5

DD0002