



SGM3733B

White LED Driver with PWM

Brightness Control in Small Packages

GENERAL DESCRIPTION

With a 40V rated integrated switch FET, the SGM3733B is a boost converter that drives LEDs in series. The boost converter runs at 650kHz fixed switching frequency to reduce output ripple, improve conversion efficiency, and allows for the use of small external components.

The default white LED current is set with the external sensor resistor R_{SET} , and the feedback voltage is regulated to 200mV, as shown in the typical application. During the operation, the LED current can be controlled using PWM signal through the CTRL pin. The duty cycle of pulse width modulation (PWM) signal determines the feedback reference voltage. In PWM mode, the SGM3733B does not burst the LED current; therefore, it does not generate audible noises on the output capacitor. For maximum protection, the device features integrated open LED protection that disables the SGM3733B to prevent the output voltage from exceeding the IC's absolute maximum voltage ratings during open LED conditions.

The SGM3733B is available in Green TDFN-2×2-6L and TSOT-23-6 packages. It operates over an ambient temperature range of -40°C to +85°C.

FEATURES

- Input Voltage Range: 2.7V to 20V
- 38V Open LED Protection
- 200mV Reference Voltage
- 500kΩ Pull-Down Resistor on CTRL Pin
- PWM Brightness Control
- 5kHz to 100kHz PWM Dimming Frequency Range
- Soft-Start Function
- Up to 90% Efficiency
- -40°C to +85°C Operating Temperature Range
- Available in Green TDFN-2×2-6L and TSOT-23-6 Packages

APPLICATIONS

- Cellular Phones
- Portable Media Players
- Ultra Mobile Devices
- GPS Receivers
- White LED Backlighting for Media Form Factor Display

TYPICAL APPLICATION

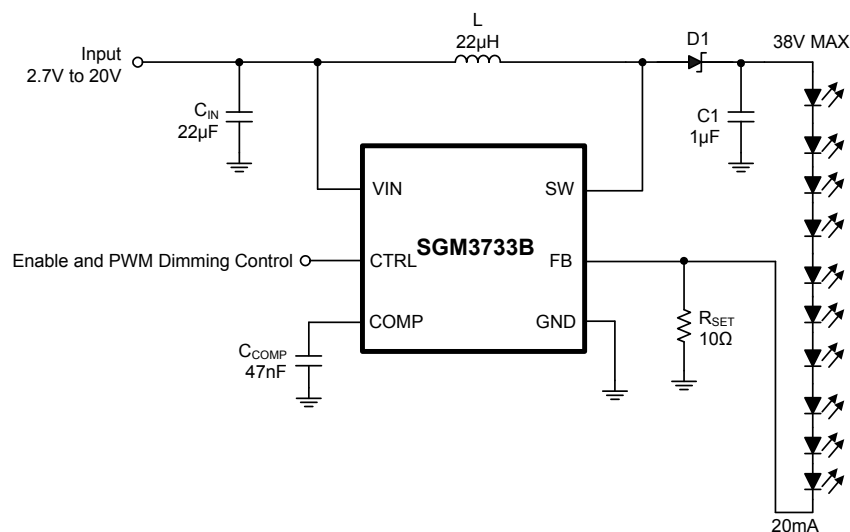

Figure 1. Typical Application Circuit

PACKAGE/ORDERING INFORMATION

MODEL	PACKAGE DESCRIPTION	SPECIFIED TEMPERATURE RANGE	ORDERING NUMBER	PACKAGE MARKING	PACKING OPTION
SGM3733B	TDFN-2x2-6L	-40°C to +85°C	SGM3733BYTDI6G/TR-V1	SH2 VXXX	Tape and Reel, 3000
	TSOT-23-6	-40°C to +85°C	SGM3733BYTN6G/TR-V1	SH0XX	Tape and Reel, 3000

Green (RoHS & HSF): SG Micro Corp defines "Green" to mean Pb-Free (RoHS compatible) and free of halogen substances. If you have additional comments or questions, please contact your SGMICRO representative directly.

MARKING INFORMATION

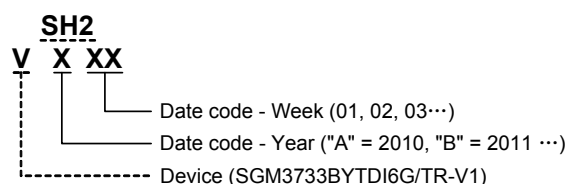

For example: SH2
VF21 (2015, 21st Week)

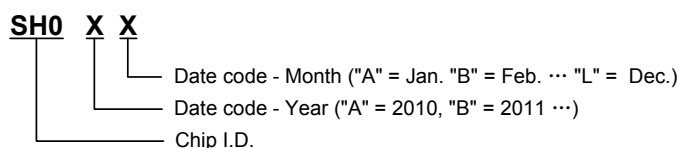

For example: SH0EA (2014, January)

ABSOLUTE MAXIMUM RATINGS

Supply Voltage on VIN.....	-0.3V to 22V
Voltage on CTRL	-0.3V to 6V
Voltages on FB and COMP.....	-0.3V to 3V
Voltage on SW	-0.3V to 40V
Package Thermal Resistance	
TDFN-2x2-6L, θ_{JA}	120°C/W
TSOT-23-6, θ_{JA}	190°C/W
Storage Temperature Range	-65°C to +150°C
Junction Temperature.....	150°C
Lead Temperature (Soldering 10 sec)	260°C
ESD Susceptibility	
HBM.....	4000V
MM.....	300V

RECOMMENDED OPERATING CONDITIONS

Input Voltage Range	2.7V to 20V
Operating Temperature Range	-40°C to +85°C

OVERSTRESS CAUTION

Stresses beyond those listed may cause permanent damage to the device. Functional operation of the device at these or any other conditions beyond those indicated in the operational section of the specification is not implied. Exposure to absolute maximum rating conditions for extended periods may affect reliability.

ESD SENSITIVITY CAUTION

This integrated circuit can be damaged by ESD if you don't pay attention to ESD protection. SGMICRO recommends that all integrated circuits be handled with appropriate precautions. Failure to observe proper handling and installation procedures can cause damage. ESD damage can range from subtle performance degradation to complete device failure. Precision integrated circuits may be more susceptible to damage because very small parametric changes could cause the device not to meet its published specifications.

DISCLAIMER

SG Micro Corp reserves the right to make any change in circuit design, specification or other related things if necessary without notice at any time.

PIN CONFIGURATIONS

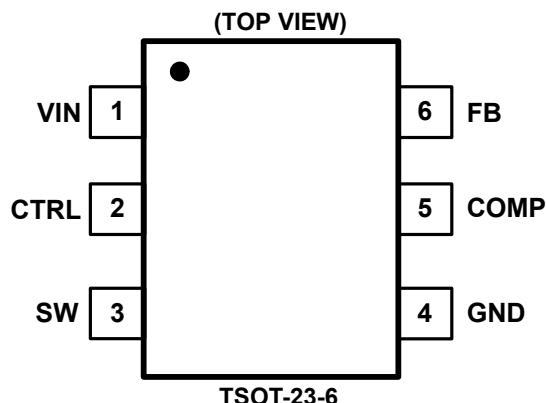
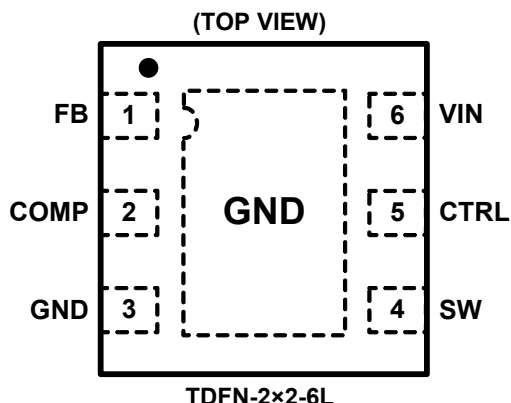

PIN DESCRIPTION

PIN		NAME	I/O	FUNCTION
TSOT-23-6	TDFN-2x2-6L			
1	6	VIN	I	Input Supply Pin. Connect VIN to a supply voltage between 2.7V and 20V.
2	5	CTRL	I	Control Pin of the Boost Regulator. It is a multi-functional pin which can be used for enable and PWM dimming control.
3	4	SW	I	Switching Node of the IC. Connect the inductor between the VIN and SW pin. This pin is also used to sense the output voltage for open LED protection.
4	3	GND	O	Ground.
5	2	COMP	O	Output of the Transconductance Error Amplifier. Connect an external capacitor to this pin to compensate the converter.
6	1	FB	I	Feedback Pin for Current. Connect the sense resistor from FB to GND.
—	Exposed Pad	GND	—	The exposed pad should be soldered to the analog ground plane. If possible, use thermal via to connect to ground plane for ideal power dissipation.

ELECTRICAL CHARACTERISTICS

($V_{IN} = 3.6V$, $V_{CTRL} = V_{IN}$, $C_{IN} = 22\mu F$, Full = $-40^{\circ}C$ to $+85^{\circ}C$, typical values are at $T_A = +25^{\circ}C$, unless otherwise noted.)

PARAMETER	SYMBOL	CONDITIONS	TEMP	MIN	TYP	MAX	UNITS
SUPPLY CURRENT							
Input Voltage Range	V_{IN}		+25°C	2.7		20	V
Operating Quiescent Current into VIN	I_Q	$V_{FB} = 400mV$	+25°C		0.4	0.6	mA
Shutdown Current	I_{SD}	$V_{CTRL} = GND$, $V_{IN} = 4.2V$	+25°C			1	μA
Under-Voltage Lockout Threshold	UVLO	V_{IN} falling	+25°C		2.2	2.5	V
Under-Voltage Lockout Hysteresis	V_{HYS}		+25°C		70		mV
ENABLE AND REFERENCE CONTROL							
CTRL Logic High Voltage	V_{CTRLH}	$V_{IN} = 2.7V$ to $20V$	Full	1.5			V
CTRL Logic Low Voltage	V_{CTRLL}	$V_{IN} = 2.7V$ to $20V$	Full			0.35	V
CTRL Pull Down Resistor	R_{CTRL}		+25°C	400	500	800	k Ω
CTRL Pulse Width to Shutdown	t_{OFF}	CTRL high to low	+25°C	2.5			ms
POWER SWITCH							
N-Channel Leakage Current	I_{LN_NFET}	$V_{SW} = 35V$, $T_A = 25^{\circ}C$	+25°C			1	μA
VOLTAGE AND CURRENT CONTROL							
Voltage Feedback Regulation Voltage	V_{REF}		Full	193	200	207.5	mV
Voltage Feedback Regulation Voltage Under Brightness Control	V_{REF_PWM}	$f_{PWM} = 10kHz$, duty cycle = 25%	Full	44	50	56	mV
		$f_{PWM} = 10kHz$, duty cycle = 10%	Full	14	20	26	
Voltage Feedback Input Bias Current	I_{FB}	$V_{FB} = 200mV$	Full		0.001	0.2	μA
Oscillator Frequency	f_s		Full		650		kHz
Minimum ON Pulse Width	t_{MIN_ON}		+25°C		80		ns
COMP Pin Sink Current	I_{SINK}		+25°C		40		μA
COMP Pin Source Current	I_{SOURCE}		+25°C		20		μA
Error Amplifier Transconductance	G_{EA}		Full	160	280	400	μmho
OC AND OLP							
N-Channel MOSFET Current Limit	I_{LIM}		+25°C		0.7		A
Open LED Protection Threshold	V_{OVP}	Measured on the SW pin	Full	35.5	38	39.5	V
V_{REF} Filter Time Constant	t_{REF}		+25°C		130		μs
PWM BRIGHTNESS CONTROL							
PWM Dimming Frequency	f_{PWM}		Full	5		100	kHz
Minimum PWM On-Time			+25°C	80			ns
Minimum Stable Duty Cycle	D_{MIN}		+25°C	2.5			%
THERMAL SHUTDOWN							
Thermal Shutdown Threshold	T_{SHDN}				150		$^{\circ}C$
Thermal Shutdown Threshold Hysteresis	T_{HYS}				15		$^{\circ}C$

RECOMMENDED COMPONENTS OF TEST CIRCUITS

COMPONENT		COMPONENT	
INDUCTOR	22 μ H/CD75NP-220KC	CAPACITOR	22 μ F/C2012X7R1H226KT
	10 μ H/CD75NP-100KC		1 μ F/C2012X7R1H105KT
DIODE	MBR0540		47nF/C0603X7S0J473M030BB

TYPICAL PERFORMANCE CHARACTERISTICS

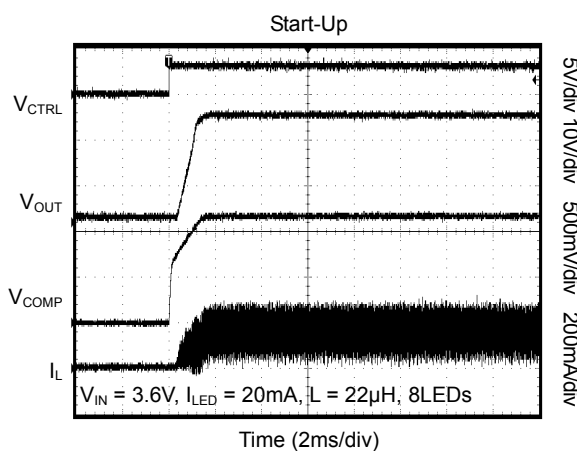
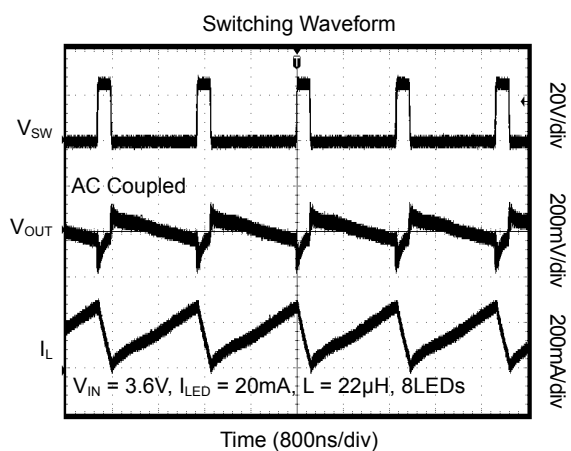
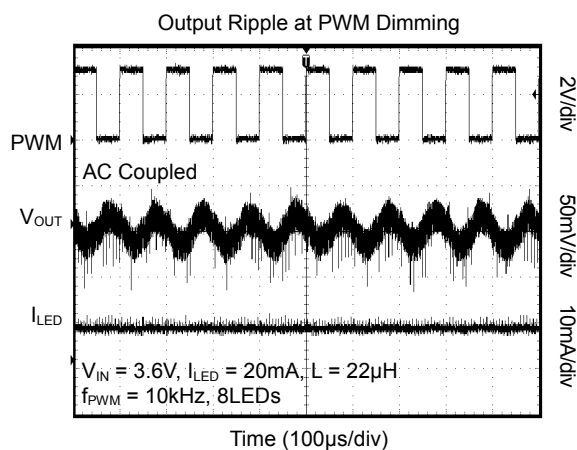
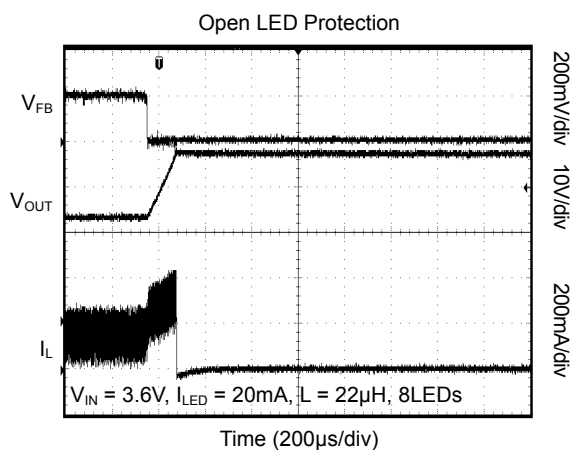

TYPICAL PERFORMANCE CHARACTERISTICS

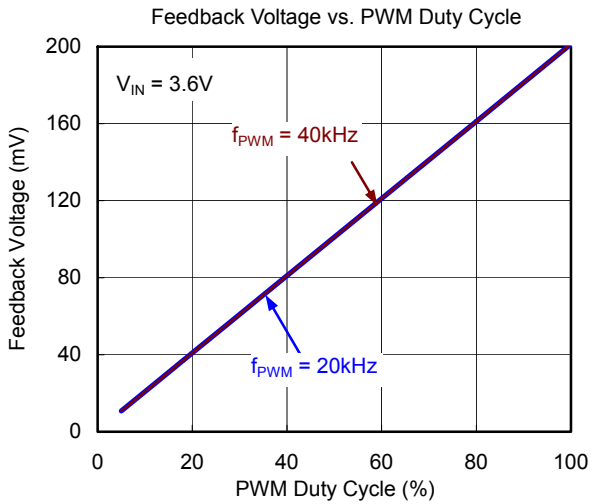
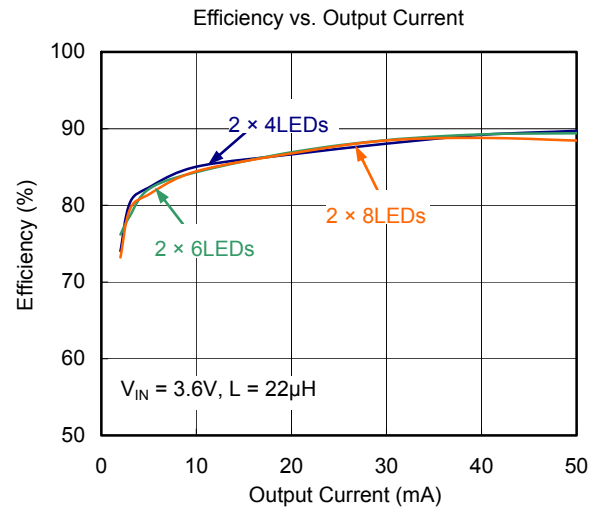
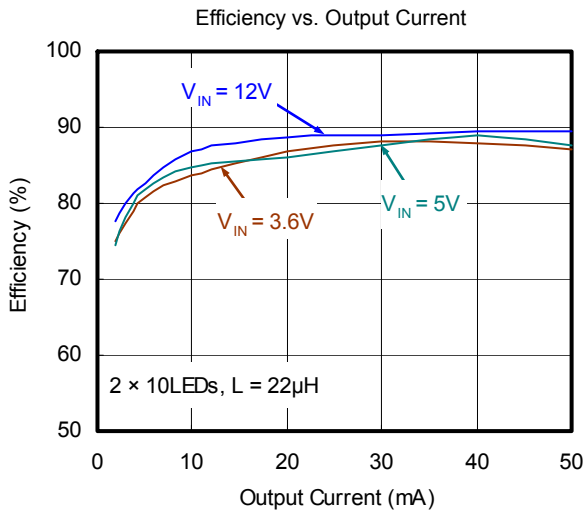

FUNCTIONAL BLOCK DIAGRAM

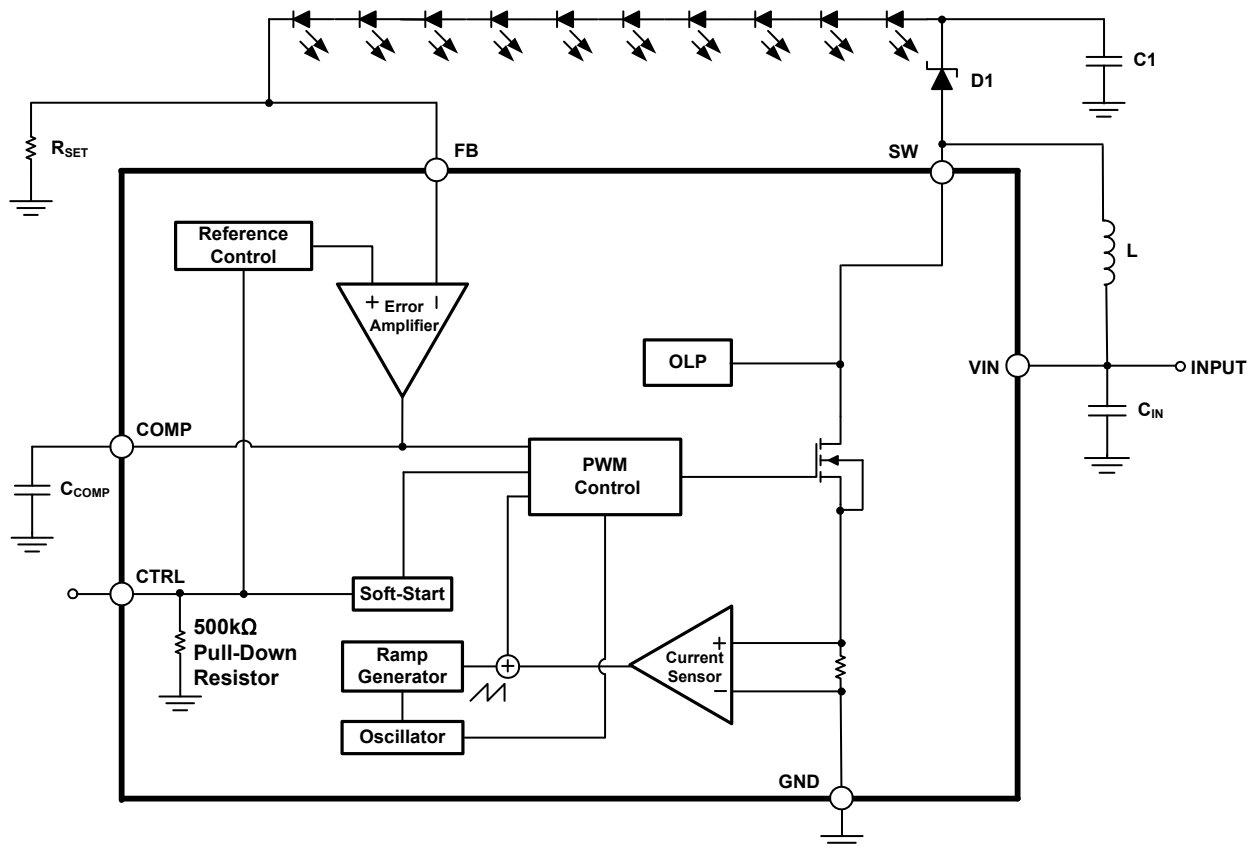

Figure 2. SGM3733B Block Diagram

DETAILED DESCRIPTION

The SGM3733B is a high efficiency, high output voltage boost converter in small package size. The device is ideal for driving white LED in series. The serial LED connection provides even illumination by sourcing the same output current through all LEDs, eliminating the need for expensive factory calibration. The device integrates 40V/0.7A switch FET and operates in pulse width modulation (PWM) with 650kHz fixed switching frequency. For operation see the FUNCTIONAL BLOCK DIAGRAM. The duty cycle of the converter is set by the error amplifier output and the current signal applied to the PWM control comparator. The control architecture is based on traditional current-mode control; therefore, a slope compensation is added to the current signal to allow stable operation for duty cycles larger than 40%. The feedback loop regulates the FB pin to a low reference voltage (200mV typical), reducing the power dissipation in the current sense resistor.

Open LED Protection (OLP)

Open LED protection circuitry prevents IC damage as the result of white LED disconnection. The SGM3733B monitors the voltage at the SW pin during each switching cycle. The switch FET will be turned off, when the SW voltage exceeds the V_{OVP} threshold for 8 switching clock cycles. The switch FET will switch after about 12ms. When the above condition is met, the protection circuitry will work again.

Current Program

The FB voltage is regulated by a low 200mV reference voltage. The LED current is programmed externally using a current sense resistor in series with the LED string. The value of the R_{SET} is calculated using Equation 1.

$$I_{LED} = \frac{V_{FB}}{R_{SET}} \quad (1)$$

Where:

I_{LED} = output current of LEDs

V_{FB} = regulated voltage of FB

R_{SET} = current sense resistor

The output current tolerance depends on the FB accuracy and the current sensor resistor accuracy.

Shutdown

The SGM3733B enters shutdown mode when the CTRL voltage is logic low for more than 2.5ms. During shutdown, the input supply current for the device is less than 1 μ A. Although the internal FET does not switch in shutdown, there is still a DC current path between the input and the LEDs through the inductor and Schottky diode. The minimum forward voltage of the LED array must exceed the maximum input voltage to ensure that the LEDs remain off in shutdown. However, in the typical application with two or more LEDs, the forward voltage is large enough to reverse bias the Schottky and keep leakage current low.

DETAILED DESCRIPTION

LED Brightness Dimming Mode Selection

The CTRL pin is used for the control input for enable and PWM dimming mode. The range of PWM dimming frequency is from 5kHz to 100kHz, and the recommended minimum PWM duty cycle is 2.5% for no blind dimming. When the CTRL pin is constantly high, the FB voltage is regulated to 200mV typically. However, the CTRL pin allows a PWM signal to reduce this regulation voltage; therefore, it achieves LED brightness dimming. The relationship between the duty cycle and FB voltage is given by Equation 2:

$$V_{FB} = \text{Duty} \times 200\text{mV} \quad (2)$$

Where:

Duty = duty cycle of the PWM signal

200mV = internal reference voltage

As shown in Figure 3, the IC chops up the internal 200mV reference voltage at the duty cycle of the PWM signal. The pulse signal is then filtered by an internal low pass filter. The output of the filter is connected to the error amplifier as the reference voltage for the FB pin regulation. Therefore, although a PWM signal is used for brightness dimming, only the WLED DC current is modulated, which is often referred as analog dimming. This eliminates the audible noise which often occurs when the LED current is pulsed in replica of the frequency and duty cycle of PWM control. Unlike other scheme which filters the PWM signal for analog dimming, SGM3733B regulation voltage is independent of the PWM logic voltage level which often has large variations.

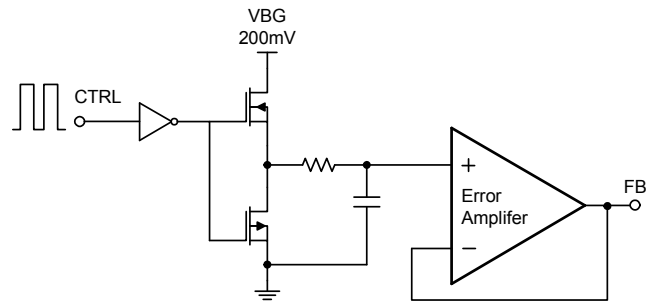

Figure 3. Block Diagram of Programmable FB Voltage Using PWM Signal

Under-Voltage Lockout

An under-voltage lockout prevents operation of the device at input voltages below typical 2.2V. When the input voltage is below the under-voltage threshold, the device is shutdown and the internal switch FET is turned off. If the input voltage rises by under-voltage lockout hysteresis, the IC restarts.

Thermal Shutdown

An internal thermal shutdown turns off the device when the typical junction temperature of 150°C is exceeded. The device is released from shutdown automatically when the junction temperature decreases by 15°C.

APPLICATION INFORMATION

Maximum Output Current

The over-current limit in a boost converter limits the maximum input current and thus maximum input power for a given input voltage. Maximum output power is less than maximum input power due to power conversion losses. Therefore, the current limit setting, input voltage, output voltage and efficiency can all change maximum current output. The current limit clamps the peak inductor current; therefore, the ripple has to be subtracted to derive maximum DC current. The ripple current is a function of switching frequency, inductor value and duty cycle. The following equations take into account of all the above factors for maximum output current calculation.

$$I_p = \frac{1}{L \times f_s \times \left(\frac{1}{V_{OUT} + V_f - V_{IN}} + \frac{1}{V_{IN}} \right)} \quad (3)$$

Where:

I_p = inductor peak-to-peak ripple

L = inductor value

V_f = Schottky diode forward voltage

f_s = switching frequency

V_{OUT} = output voltage of the boost converter. It is equal to the sum of V_{FB} and the voltage drop across LEDs.

$$I_{OUT_MAX} = \frac{V_{IN} \times (I_{LIM} - I_p / 2) \times \eta}{V_{OUT}} \quad (4)$$

Where:

I_{OUT_MAX} = maximum output current of the boost converter

I_{LIM} = over-current limit

η = efficiency

For instance, when V_{IN} is 3.0V, 8 LEDs output equivalent to V_{OUT} of 26V, the inductor is 22 μ H, the Schottky forward voltage is 0.2V; and then the maximum output current is 65mA in typical condition. When V_{IN} is 5V, 10 LEDs output equivalent to V_{OUT} of 32V, the inductor is 22 μ H, the Schottky forward voltage is 0.2V; and then the maximum output current is 85mA in typical condition.

Inductor Selection

The selection of the inductor affects steady state operation as well as transient behavior and loop stability. These factors make it the most important component in power regulator design. There are three important inductor specifications, inductor value, DC resistance and saturation current. Considering inductor value alone is not enough.

The inductor value determines the inductor ripple current. Choose an inductor that can handle the necessary peak current without saturating, according to half of the peak-to-peak ripple current given by Equation 3, pause the inductor DC current given by:

$$I_{IN_DC} = \frac{V_{OUT} \times I_{OUT}}{V_{IN} \times \eta} \quad (5)$$

Inductor values can have $\pm 20\%$ tolerance with no current bias. When the inductor current approaches saturation level, its inductance can decrease 20% to 35% from the 0A value depending on how the inductor vendor defines saturation current. Using an inductor with a smaller inductance value forces discontinuous PWM when the inductor current ramps down to zero before the end of each switching cycle. This reduces the boost converter's maximum output current, causes large input voltage ripple and reduces efficiency. Large inductance value provides much more output current and higher conversion efficiency. For these reasons, a 6.8 μ H to 22 μ H inductor value range is recommended. A 22 μ H inductor optimized the efficiency for most application while maintaining low inductor peak-to-peak ripple.

SGM3733B has built-in slope compensation to avoid sub-harmonic oscillation associated with current mode control. If the inductor value is lower than 6.8 μ H, the slope compensation may not be adequate, and the loop can be unstable. Therefore, customers need to verify the inductor in their application if it is different from the recommended values.

APPLICATION INFORMATION

Schottky Diode Selection

The high switching frequency of the SGM3733B demands a high-speed rectification for optimum efficiency. Ensure that the diode's average and peak current rating exceeds the average output current and peak inductor current. In addition, the diode's reverse breakdown voltage must exceed the open LED protection voltage.

Compensation Capacitor Selection

The compensation capacitor C_{COMP} , connected from COMP pin to GND, is used to stabilize the feedback loop of the SGM3733B. A ceramic capacitor in the range of 22nF to 220nF for C_{COMP} is suitable for most applications.

Input and Output Capacitor Selection

The output capacitor is mainly selected to meet the requirements for the output ripple and loop stability. This ripple voltage is related to the capacitor's capacitance and its equivalent series resistance (ESR). Assuming a capacitor with zero ESR, the minimum capacitance needed for a given ripple can be calculated by:

$$C_{OUT} = \frac{(V_{OUT} - V_{IN}) \times I_{OUT}}{V_{OUT} \times f_S \times V_{RIPPLE}} \quad (6)$$

Where, V_{RIPPLE} = peak-to-peak output ripple. The additional output ripple component caused by ESR is calculated using:

$$V_{RIPPLE_ESR} = I_{OUT} \times R_{ESR} \quad (7)$$

Due to its low ESR, V_{RIPPLE_ESR} can be neglected for ceramic capacitors, but must be considered if tantalum or electrolytic capacitors are used.

Care must be taken when evaluating a ceramic capacitors derating under DC bias, aging and AC signal. For example, larger form factor capacitors (in 1206 size) have a resonant frequency in the range of the switching frequency. So the effective capacitance is significantly

lower. The DC bias can also significantly reduce capacitance. Ceramic capacitors can loss as much as 50% of its capacitance at its rated voltage. Therefore, leave the margin on the voltage rating to ensure adequate capacitance at the required output voltage.

The capacitor in the range of 1 μ F to 22 μ F is recommended for input side. The output requires a capacitor in the range of 0.47 μ F to 10 μ F. The output capacitor affects the loop stability of the boost regulator. If the output capacitor is below the range, the boost regulator can potentially become unstable. For example, if use the output capacitor of 0.1 μ F, a 470nF compensation capacitor has to be used for the loop stable.

Thermal Considerations

The maximum IC junction temperature should be restricted to 150°C under normal operating conditions. This restriction limits the power dissipation of the SGM3733B. Calculate the maximum allowable dissipation, $P_{D(MAX)}$, and keep the actual dissipation less than or equal to $P_{D(MAX)}$. The maximum-power-dissipation limit is determined using Equation 8:

$$P_{D(MAX)} = \frac{150^\circ\text{C} - T_A}{\theta_{JA}} \quad (8)$$

Where, T_A is the maximum ambient temperature for the application. θ_{JA} is the thermal resistance junction-to-ambient given in Power Dissipation Table.

The SGM3733B comes in TDFN and TSOT packages. Compared with the TSOT package, the TDFN package has better heat dissipation. This package includes a thermal pad that improves the thermal capabilities of the package. The θ_{JA} of the TDFN package greatly depends on the PCB layout and thermal pad connection. The thermal pad must be soldered to the analog ground on the PCB. Using thermal vias underneath the thermal pad as illustrated in the layout example.

APPLICATION INFORMATION

PCB Layout Considerations

As for all switching power supplies, especially those high frequency and high current ones, layout is an important design step. If layout is not carefully done, the regulator could suffer from instability as well as noise problems. To reduce switching losses, the SW pin rise and fall times are made as short as possible. To prevent radiation of high frequency resonance problems, proper layout of the high frequency switching path is essential. Minimize the length and area of all traces connected to the SW pin and always use a ground plane under the switching regulator to minimize inter-plane coupling. The loop including the PWM switch, Schottky diode, and output capacitor, contains high current rising and falling in nanosecond and

should be kept as short as possible.

Connect the exposed paddle to the PCB ground plane using at least two vias. The input and the output bypass capacitors should be placed as close to the IC as possible. Minimize trace lengths between the IC and the inductor, the diode and the output capacitor; keep these traces short, direct, and wide.

A recommended PCB layout is shown in Figure 4. In order to dissipate the package heat, the package center pad (MC) must be connected to a large copper area on the ground plane underneath using multiple vias.

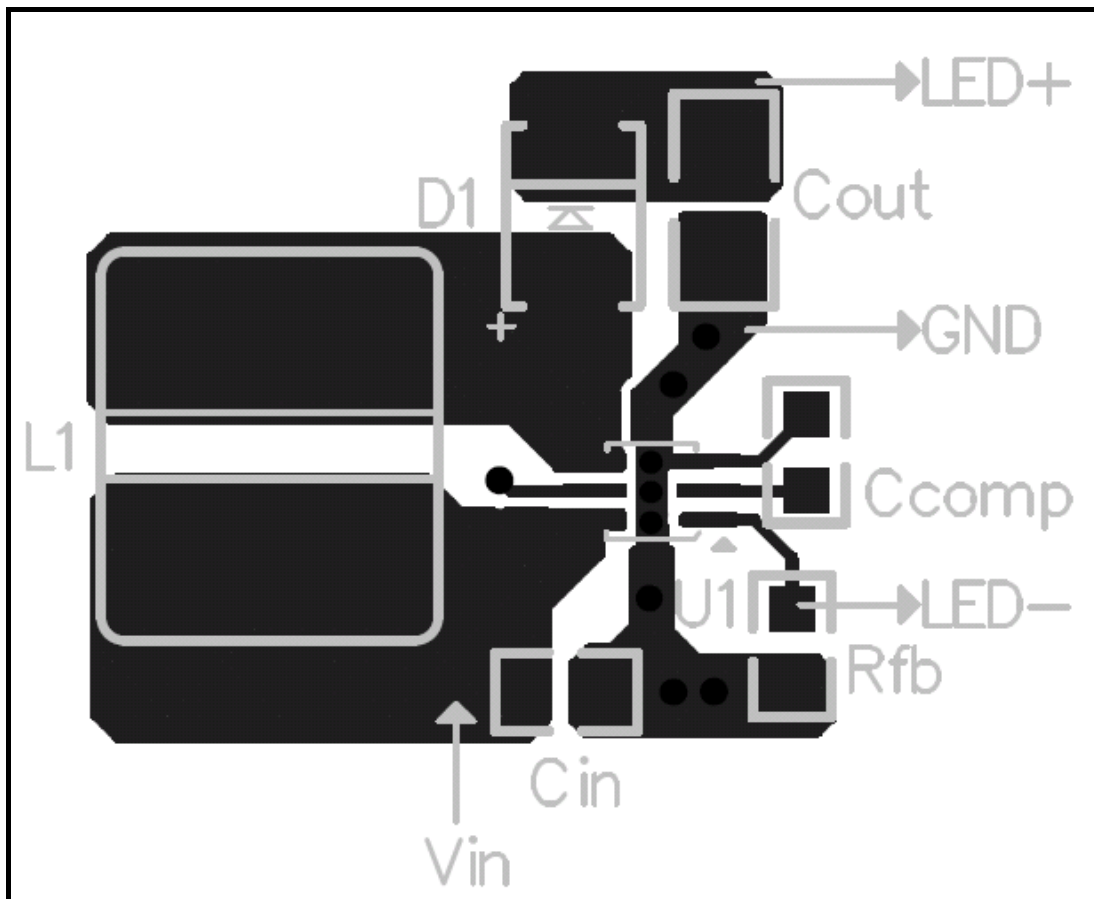

Figure 4. Recommended PCB Layout

ADDITIONAL TYPICAL APPLICATIONS

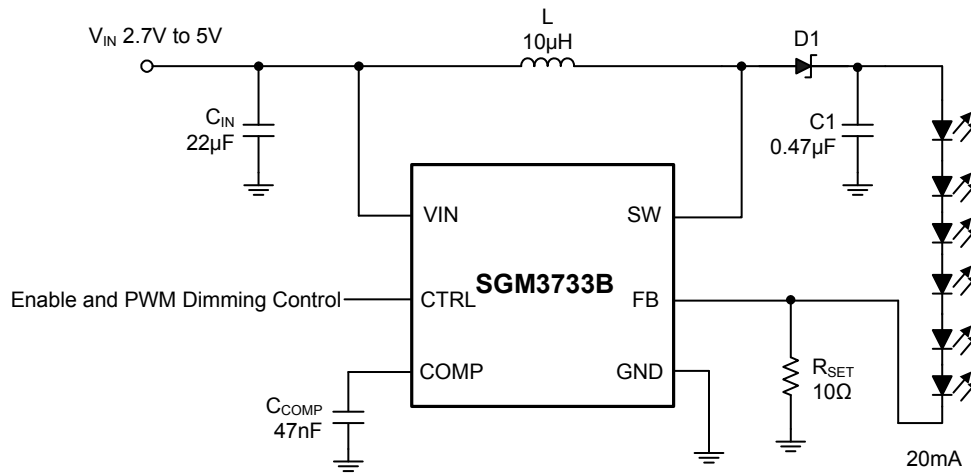

Figure 5. Li-ion Driver for 6 White LEDs

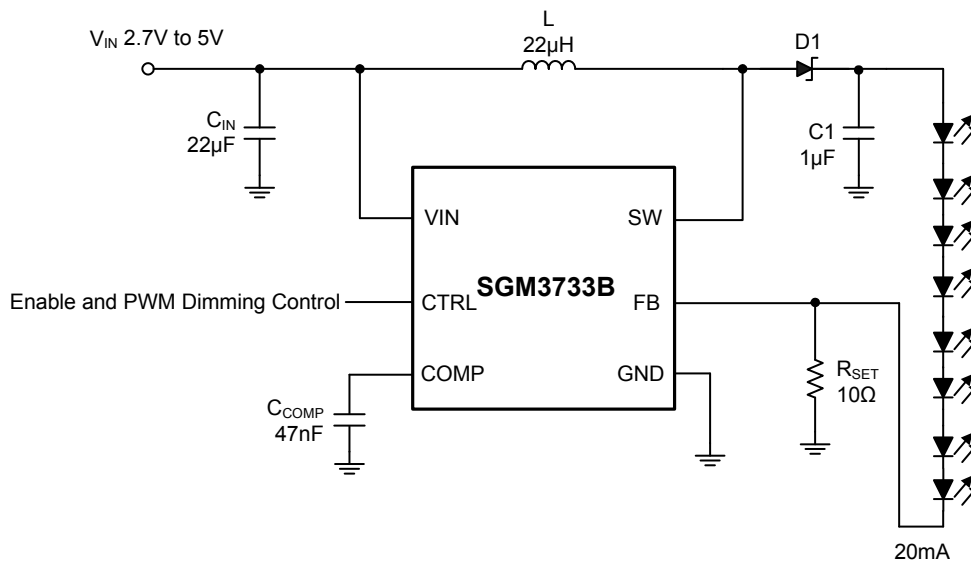
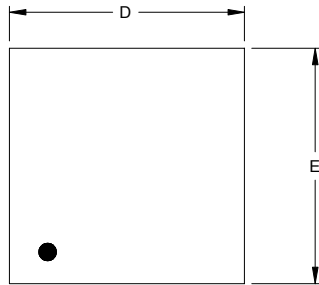

Figure 6. Li-ion Driver for 8 White LEDs

PACKAGE OUTLINE DIMENSIONS

TDFN-2x2-6L



TOP VIEW

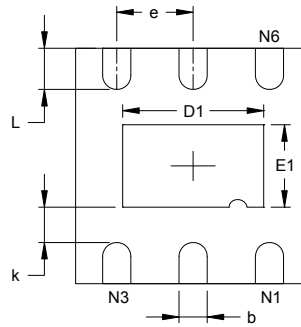

BOTTOM VIEW

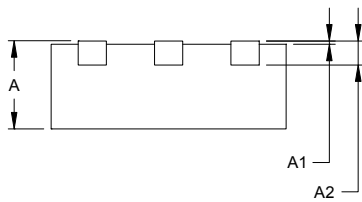

SIDE VIEW

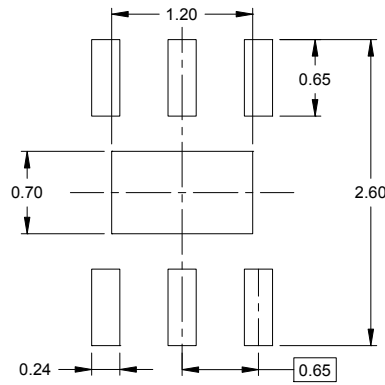

RECOMMENDED LAND PATTERN (Unit: mm)

Symbol	Dimensions In Millimeters		Dimensions In Inches	
	MIN	MAX	MIN	MAX
A	0.700	0.800	0.028	0.031
A1	0.000	0.050	0.000	0.002
A2	0.203 REF		0.008 REF	
D	1.900	2.100	0.075	0.083
D1	1.100	1.300	0.043	0.051
E	1.900	2.100	0.075	0.083
E1	0.600	0.800	0.024	0.031
k	0.200 MIN		0.008 MIN	
b	0.180	0.300	0.007	0.012
e	0.650 TYP		0.026 TYP	
L	0.250	0.450	0.010	0.018

PACKAGE OUTLINE DIMENSIONS

TSOT-23-6

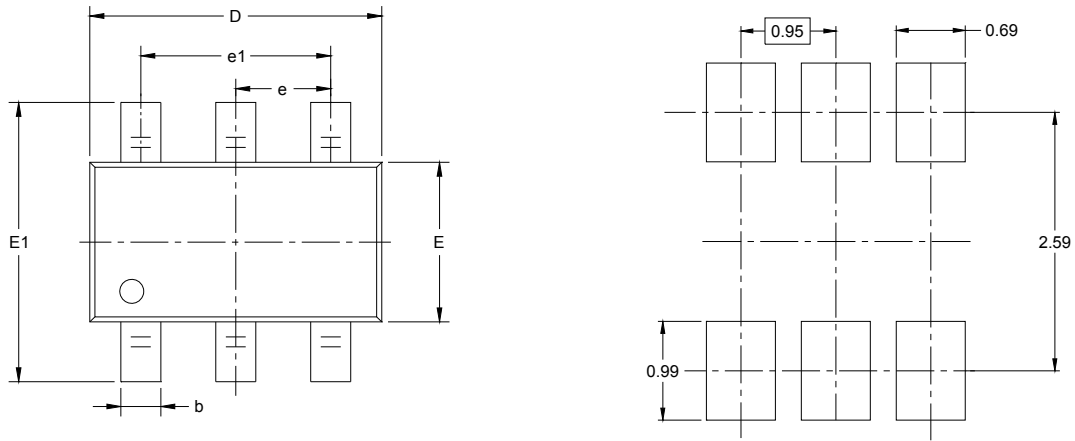

RECOMMENDED LAND PATTERN (Unit: mm)

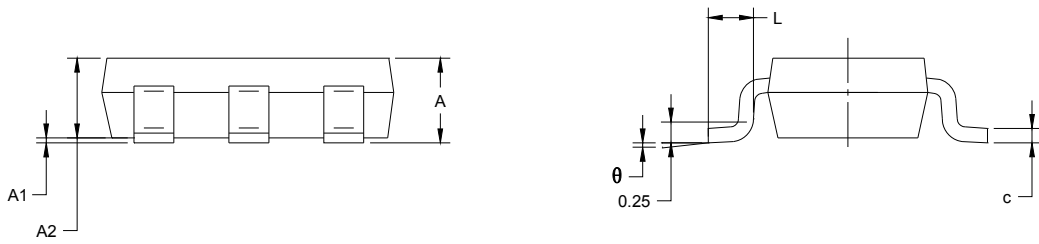

Symbol	Dimensions In Millimeters		Dimensions In Inches	
	MIN	MAX	MIN	MAX
A	0.700	0.900	0.028	0.035
A1	0.000	0.100	0.000	0.004
A2	0.700	0.800	0.028	0.031
b	0.350	0.500	0.014	0.020
c	0.080	0.200	0.003	0.008
D	2.820	3.020	0.111	0.119
E	1.600	1.700	0.063	0.067
E1	2.650	2.950	0.104	0.116
e	0.950 BSC		0.037 BSC	
e1	1.900 BSC		0.075 BSC	
L	0.300	0.600	0.012	0.024
θ	0°	8°	0°	8°

PACKAGE INFORMATION

TAPE AND REEL INFORMATION

REEL DIMENSIONS

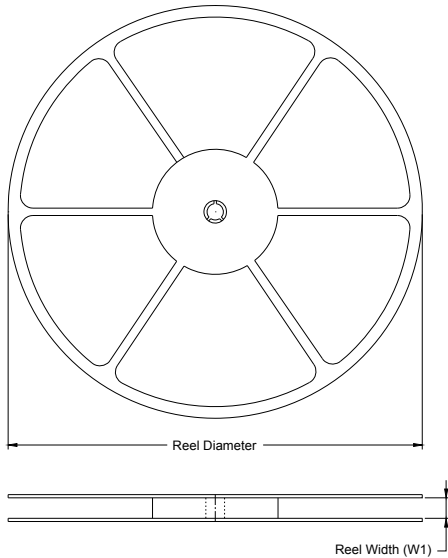

TAPE DIMENSIONS

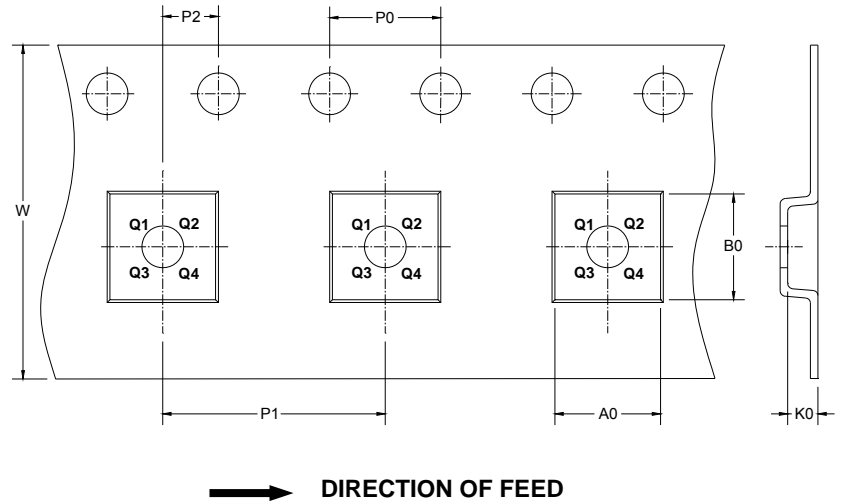

NOTE: The picture is only for reference. Please make the object as the standard.

KEY PARAMETER LIST OF TAPE AND REEL

Package Type	Reel Diameter	Reel Width W1 (mm)	A0 (mm)	B0 (mm)	K0 (mm)	P0 (mm)	P1 (mm)	P2 (mm)	W (mm)	Pin1 Quadrant
TDFN-2x2-6L	7"	9.5	2.30	2.30	1.10	4.00	4.00	2.00	8.00	Q1
TSOT-23-6	7"	9.5	3.2	3.1	1.1	4.0	4.0	2.0	8.0	Q3

000001

PACKAGE INFORMATION

CARTON BOX DIMENSIONS

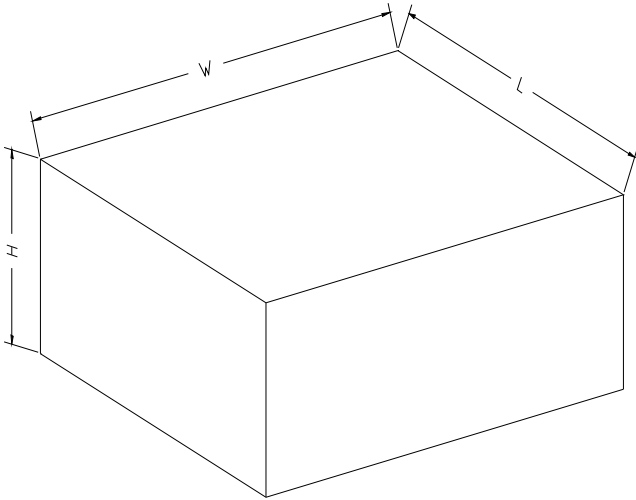

NOTE: The picture is only for reference. Please make the object as the standard.

KEY PARAMETER LIST OF CARTON BOX

Reel Type	Length (mm)	Width (mm)	Height (mm)	Pizza/Carton
7" (Option)	368	227	224	8
7"	442	410	224	18

D100002