



SGM3144

6-Channel PWM Dimming Charge Pump White LED Driver

GENERAL DESCRIPTION

The SGM3144 is a high performance white LED driver. It integrates current sources and automatic mode selection charge pump. The part maintains the high efficiency by utilizing a 1×/1.5× fractional charge pump and low dropout current sources. The small equivalent 1× mode open loop resistance and ultra-low dropout voltage of current source extend the operating time of 1× mode and optimize the efficiency of Li-ion battery in white LED applications.

The SGM3144 supports up to 6 white LEDs and regulates a constant current which the initial value can be set by an internal resistor. The part implements PWM dimming to adjust the brightness of LED. Users can easily configure the LED current from 0mA to 27mA by a digital PWM signal. SGM3144 can be turned off by EN pin. The operating voltage range is 2.7V to 5.5V. Internal soft-start circuitry effectively reduces the in-rush current while both start-up and mode transition.

The SGM3144 is available in Green TQFN-3×3-16L package and is rated over the -40°C to +85°C temperature range.

FEATURES

- **Input Voltage Range: 2.7V to 5.5V**
- **Drives up to 6 LEDs at 27mA Each**
- **PWM Dimming**
- **High Efficiency by Fractional Conversion with 1× and 1.5× Modes**
- **Switching Frequency: 0.93MHz**
- **Regulated Output Current with ±4.8% Matching**
- **Internal Soft-Start Limits Inrush Current**
- **Low Input Ripple and Low EMI**
- **Over Current and Over Temperature Protection**
- **Under Voltage Lockout with Hysteresis**
- **Available in Green TQFN-3×3-16L Package**

APPLICATIONS

Mobile Phone, DSC, MP3
White LED Backlighting
LCD Display Supply



PACKAGE/ORDERING INFORMATION

MODEL	ORDER NUMBER	PACKAGE DESCRIPTION	SPECIFIED TEMPERATURE RANGE	PACKAGE OPTION	MARKING INFORMATION
SGM3144	SGM3144YTQ16G/TR	TQFN-3×3-16L	-40°C to +85°C	Tape and Reel, 3000	3144TQ

ABSOLUTE MAXIMUM RATINGS

V _{IN} to GND.....	-0.3V to 6V
The Other Pins to GND.....	-0.3V to V _{IN}
Power Dissipation, P _D @ T _A = 25°C	
TQFN-3×3-16L.....	1.47W
Storage Temperature Range.....	-65°C to +150°C
Junction Temperature.....	150°C
Operating Temperature Range.....	-40°C to +85°C
Lead Temperature Range (Soldering 10 sec)	
.....	260°C
ESD Susceptibility	
HBM.....	2000V
MM.....	200V

NOTE:

Stresses beyond those listed under “Absolute Maximum Ratings” may cause permanent damage to the device. These are stress ratings only, and functional operation of the device at these or any other conditions beyond those indicated in the operational sections of the specifications is not implied. Exposure to absolute maximum rating conditions for extended periods may affect device reliability.

CAUTION

This integrated circuit can be damaged by ESD if you don't pay attention to ESD protection. SGMICRO recommends that all integrated circuits be handled with appropriate precautions. Failure to observe proper handling and installation procedures can cause damage. ESD damage can range from subtle performance degradation to complete device failure. Precision integrated circuits may be more susceptible to damage because very small parametric changes could cause the device not to meet its published specifications.

SGMICRO reserves the right to make any change in circuit design, specification or other related things if necessary without notice at any time. Please contact SGMICRO sales office to get the latest datasheet.



PIN CONFIGURATION (TOP VIEW)

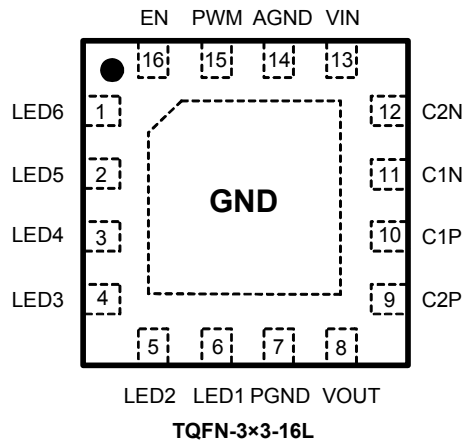

PIN DESCRIPTION

PIN	NAME	I/O	FUNCTION
1, 2, 3, 4, 5, 6	LED6 - LED1	I	Current Sink Input. Connect the cathode of the white LEDs to these inputs.
7	PGND	-	Power Ground.
8	VOUT	O	Output Voltage Source. Connect the output capacitor and the anode of the LEDs to this pin.
9	C2P	-	Positive Terminal of Bucket Capacitor 2.
10	C1P	-	Positive Terminal of Bucket Capacitor 1.
11	C1N	-	Negative Terminal of Bucket Capacitor 1.
12	C2N	-	Negative Terminal of Bucket Capacitor 2.
13	VIN	I	Supply Voltage Input.
14	AGND	-	Analog Ground.
15	PWM	I	PWM Dimming Pulse. Duty cycle = 0%, $I_{OUT} = 0\text{mA}$; duty cycle = 100%, $I_{OUT} = 27\text{mA}$.
16	EN	I	Enable or Disable SGM3144. Logic high to enable chip, logic low to disable chip. For normal operation, suggest connecting to VIN only after the VIN has settled if the VIN ramping up is slow.
Exposed Pad	GND	-	Exposed pad should be soldered to PCB board and connected to GND.

ELECTRICAL CHARACTERISTICS(V_{IN} = 3.6V, EN = V_{IN}, T_A = 25°C, unless otherwise noted.)

PARAMETER	SYMBOL	CONDITIONS	MIN	TYP	MAX	UNITS
SUPPLY VOLTAGE AND CURRENT						
Input Voltage Range	V _{IN}		2.7		5.5	V
Quiescent Power Supply Current	I _Q	V _{IN} = 4.2V, 1× Mode, I _{LEDx} = 0mA		155	240	μA
	I _Q	1.5× Mode, I _{LEDx} = 0mA		1.35		mA
Shutdown Supply Current	I _{SHDN}	EN = GND, V _{IN} = 4.2V		0.01	2.5	μA
CHARGE PUMP STAGE						
Overtolerance Limit	V _{OUT}			5.4		V
Start-Up Time		C _{OUT} = 1μF, I _{LEDx} ≥ 0.9 × I _{LEDx-set}		280		μs
Soft-Start Duration				150		μs
Switching Frequency	f		0.7	0.93	1.25	MHz
Efficiency	η	At 1× Mode before switching to 1.5× Mode		90		%
Shutdown Temperature		Temperature rising		140		°C
Shutdown Temperature Hysteresis				10		°C
Input Current Limit				300		mA
CURRENT SINKS						
Recommended Maximum Current per Current Sink	I _{LEDx}	3.2V ≤ V _{IN} ≤ 5.5V	24	27	30	mA
Current Matching between Any Two Outputs		V _{LEDx} = 3.2V, I _{LEDx} = 27mA	-4.8	1	4.8	%
Line Regulation		3.3V < V _{IN} < 5.5V, V _{LEDx} = 3.2V		1.4		%
Voltage at LED _x to GND	V _{SOURCE}	V _{IN} = 4.2V		550		mV
PWM AND EN LOGIC						
PWM Low Time for Dimming	T _{LO}		0.5			μs
PWM High Time for Dimming	T _{HI}		4			μs
Threshold	Logic-High Voltage	V _{IH}	1.2			V
	Logic-Low Voltage	V _{IL}			0.4	V
THRESHOLD OF SWITCHING BETWEEN 1× AND 1.5× MODE						
1× Mode to 1.5× Mode		V _{LEDx} = 3.2V		3.48		V
1.5× Mode to 1× Mode		V _{LEDx} = 3.2V		3.65		V

TYPICAL PERFORMANCE CHARACTERISTICS

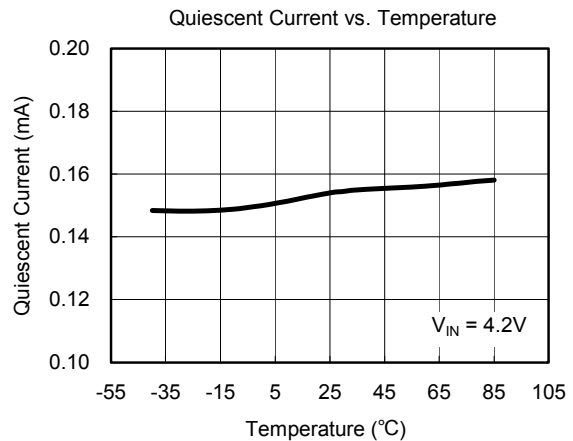
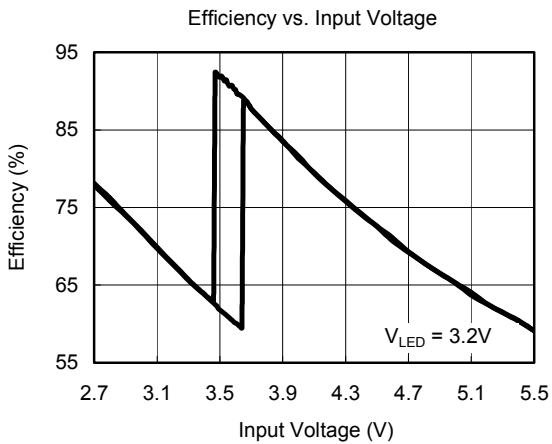
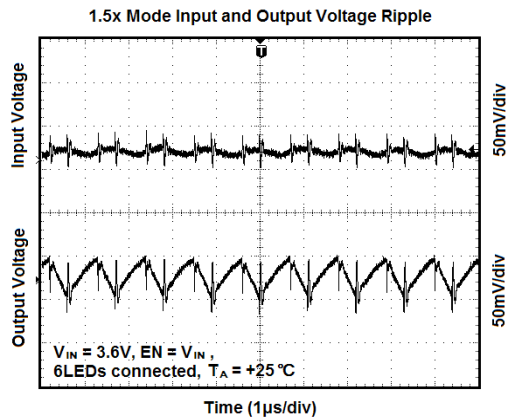
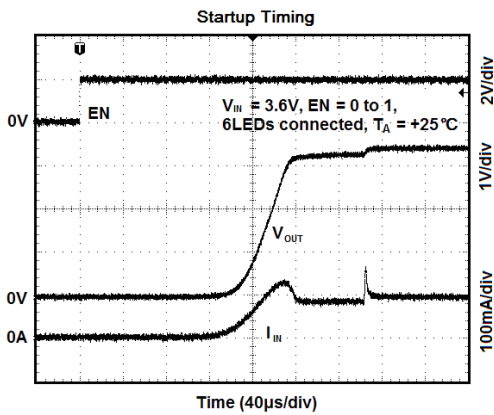
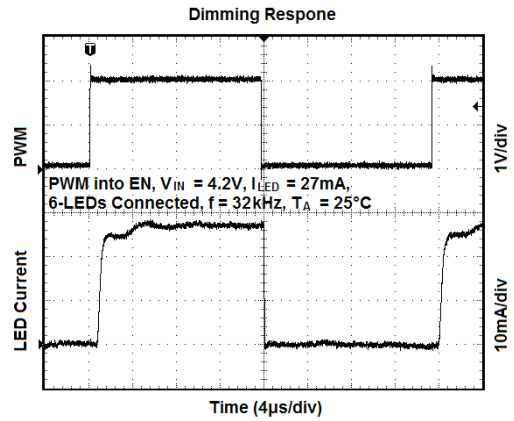
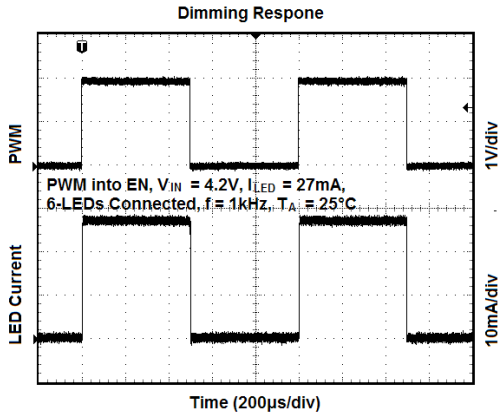

TYPICAL PERFORMANCE CHARACTERISTICS

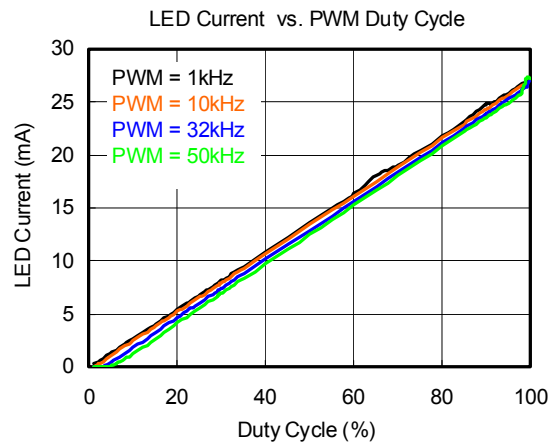
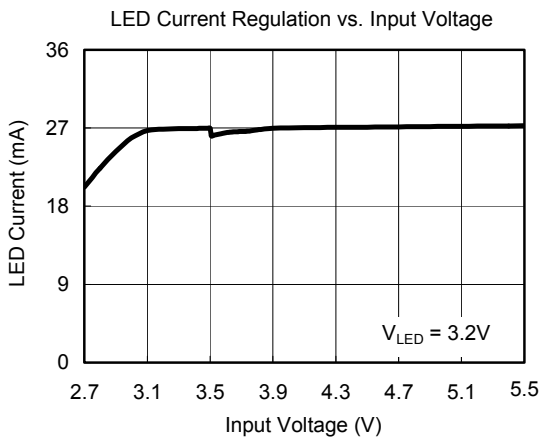
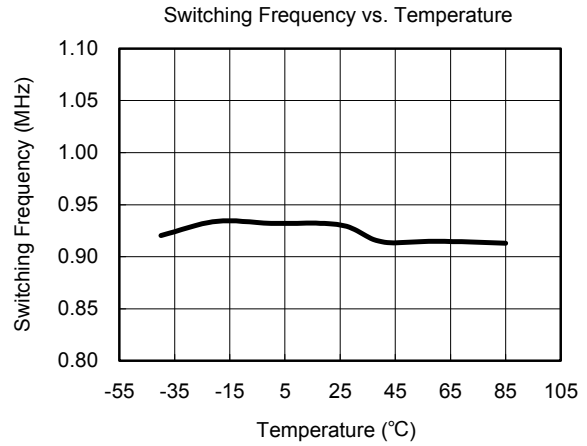
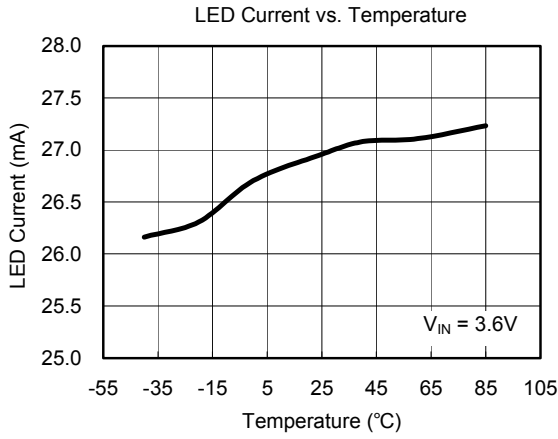

FUNCTION BLOCK DIAGRAM

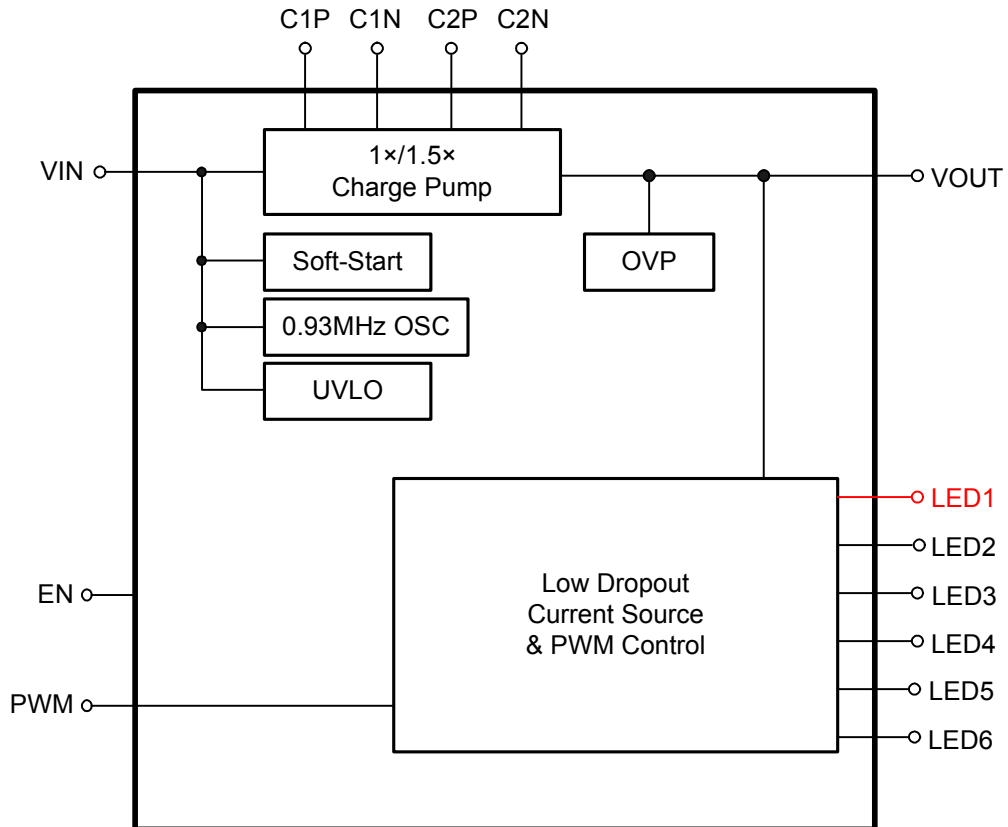

TYPICAL APPLICATION

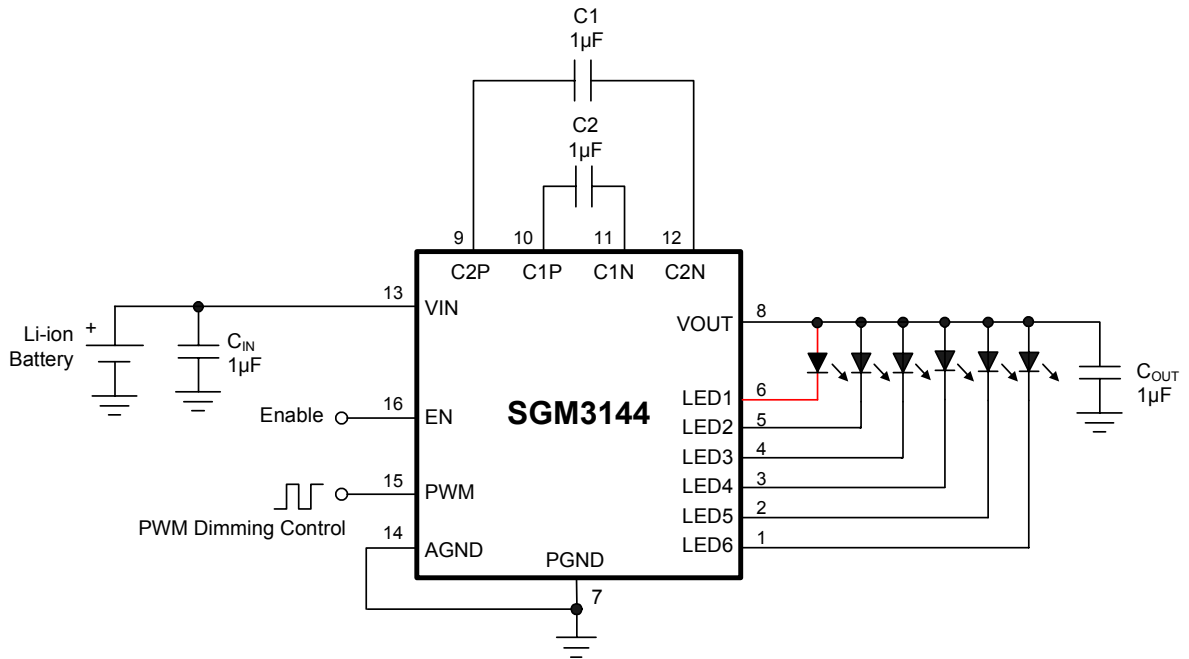

Figure 1. For 6-WLEDs Application Circuit

APPLICATION INFORMATION

The SGM3144 uses a fractional switched capacitor charge pump to power up to 6 white LEDs with a programmable current for uniform intensity. The part integrates current sources and automatic mode selection charge pump. It maintains the high efficiency by utilizing a 1×/1.5× fractional charge pump and current sources. The small equivalent 1× mode open loop resistance and ultra-low dropout voltage of current source extend the operating time of 1× mode and optimize the efficiency in white LED applications.

Input UVLO

The input operating voltage range of the SGM3144 is 2.7V to 5.5V. An input capacitor at the VIN pin could reduce ripple voltage. It is recommended to use a ceramic 1μF or larger capacitance as the input capacitor. This IC provides an under voltage lockout (UVLO) function to prevent it from unstable issue when startup. The UVLO threshold of input rising voltage is set at 2.15V typically with a hysteresis 30mV.

Soft Start

The SGM3144 employs a soft-start feature to limit the inrush current. The soft-start circuit prevents the excessive inrush current and input voltage droop. The soft-start clamps the input current over a typical period of 150μs.

Mode Decision

The SGM3144 uses a smart mode selection method to decide the working mode for optimizing the efficiency. Mode decision circuit senses the output and LED voltage for up/down selection. The SGM3144 automatically switches to 1.5× mode whenever the dropout condition is detected from the current source and returns to 1× mode whenever the dropout condition releases.

Chip Enable and Shutdown

When EN is in “High” status, SGM3144 will enter into active status. When EN is in “Low” status and SGM3144 will enter into shutdown status.

Over Voltage Protection

The SGM3144 equips over voltage protection function. When LED1 is open, the output voltage will be clamped to 5.4V.

LED Connection

The SGM3144 supports up to 6 white LEDs. The 6 LEDs are connected from VOUT to pin 1, 2, 3, 4, 5 and 6 respectively. Figure 1 shows the connection for 6-WLEDs application. LED1 to LED6 are controlled by EN pin. The SGM3144 internal current source reference circuit bases feedback from current sensed on the LED1 output. For best operation, the only requirement for this type of application is the output LED1 should always be connected to the load circuit. The other LED pins (LED2, 3, 4, 5 & 6) can be left floating if those white LEDs are not used.

LED Dimming Control Interface

An internal resistor sets the maximum LED current to be 27mA. One PWM signal at PWM pin can dim the brightness of LED from 0mA to 27mA. When duty cycle = 0%, the current is 0mA; when duty cycle = 100%, the current is 27mA.

Selecting Capacitors

To get the better performance of SGM3144, the selection of peripherally appropriate capacitor and value is very important. These capacitors determine some parameters such as input/output ripple voltage, power efficiency, and maximum supply current by charge pump. To reduce the input and output ripple effectively, the low ESR ceramic capacitors are recommended. For LED driver applications, the input voltage ripple is more important than output ripple. Input ripple is controlled by input capacitor C_{IN} , increasing the value of input capacitance can further reduce the ripple. Practically, the input voltage ripple depends on the power supply impedance. The flying capacitor C1 and C2 determine the supply current capability of the charge pump and to influence the overall efficiency of system. The lower value will improve efficiency, but it will limit the LED's current at low input voltage. For 6 × 27mA load over the entire input range of 2.7V to 5.5V, it is recommended to use a 1μF ceramic capacitor on the flying capacitor C1 and C2.



PACKAGE OUTLINE DIMENSIONS

TQFN-3×3-16L

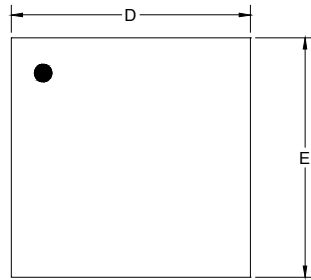

TOP VIEW

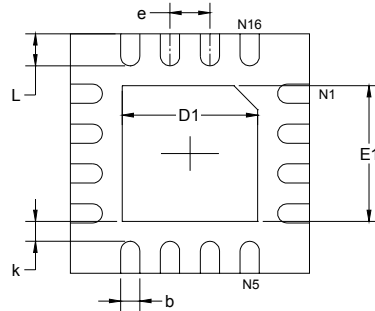

BOTTOM VIEW

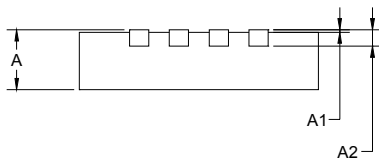

SIDE VIEW

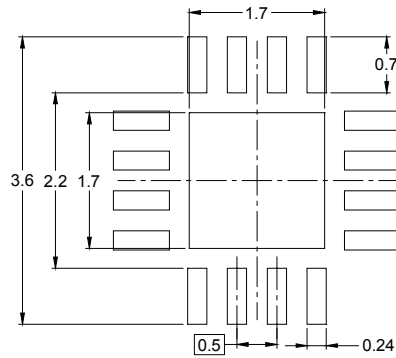

RECOMMENDED LAND PATTERN (Unit: mm)

Symbol	Dimensions In Millimeters		Dimensions In Inches	
	MIN	MAX	MIN	MAX
A	0.700	0.800	0.028	0.031
A1	0.000	0.050	0.000	0.002
A2	0.203 REF		0.008 REF	
D	2.900	3.100	0.114	0.122
D1	1.600	1.800	0.063	0.071
E	2.900	3.100	0.114	0.122
E1	1.600	1.800	0.063	0.071
k	0.200 MIN		0.008 MIN	
b	0.180	0.300	0.007	0.012
e	0.500 TYP		0.020 TYP	
L	0.300	0.500	0.012	0.020