

LB1909MC

Monolithic Digital IC

Stepping Motor Driver IC

Overview

The LB1909MC is motor driver IC that can operate on a wide supply voltage range (2.5V to 16V). The IC is ideal for use in 2-phase excitation drive of general-purpose 2-phase bipolar stepping motors including dampers for refrigerators.

Features

- Wide supply voltage range : 2.5V to 16V
- Low saturation voltage : $V_{O(sat)} = 0.25V$ typ at $I_O = 200mA$.
- Built-in shoot-through current protection circuit.
- No standby current consumption (or zero).
- Built-in thermal shutdown circuit.
- Small package : SOIC10

Specifications

Absolute Maximum Ratings at $T_a = 25^\circ C$

Parameter	Symbol	Conditions	Ratings	Unit
Maximum power source voltage	V_{CC} max		-0.3 to +20	V
Applied output voltage	V_{OUT} max		-0.3 to +20	V
Applied input voltage	V_{IN} max		-0.3 to +18	V
GND pin outflow current	I_{GND}		800	mA
Allowable power consumption	P_d max	Mounted on the specified board *	820	mW
Operating temperature	T_{opr}		-30 to +85	$^\circ C$
Storage temperature	T_{stg}		-40 to +150	$^\circ C$

* Specified board: 114.3mm × 76.1mm × 1.6mm, glass epoxy board.

Caution 1) Absolute maximum ratings represent the value which cannot be exceeded for any length of time.

Caution 2) Even when the device is used within the range of absolute maximum ratings, as a result of continuous usage under high temperature, high current, high voltage, or drastic temperature change, the reliability of the IC may be degraded. Please contact us for the further details.

Stresses exceeding Maximum Ratings may damage the device. Maximum Ratings are stress ratings only. Functional operation above the Recommended Operating Conditions is not implied. Extended exposure to stresses above the Recommended Operating Conditions may affect device reliability.

LB1909MC

Allowable Operating Range at Ta = 25°C

Parameter	Symbol	Conditions	Ratings	Unit
Supply voltage	V _{CC}		2.5 to 16	V
Input high level voltage	V _{IH}	Pins ENA, IN1, IN2	1.8 to 10	V
Input low level voltage	V _{IL}		-0.3 to +0.7	V

Electrical Characteristics at Ta = 25°C, V_{CC} = 12V

Parameter	Symbol	Conditions	Ratings			Unit
			min	typ	max	
Power source current	I _{CC0}	ENA = L		0.1	10	μA
	I _{CC1}	ENA = H		25	35	mA
Output saturation voltage	V _{OUT1}	I _{OUT} = 200mA		0.25	0.35	V
	V _{OUT2}	I _{OUT} = 400mA		0.50	0.75	V
Input current	I _{IN}	V _{IN} = 5V		120	160	μA
Thermal protection block *1						
Thermal shutdown operation temperature	T _{tSD}	Design guarantee *2		180		°C
Temperature hysteresis width	ΔT _{tSD}			60		°C
Spark killer diode						
Reverse current	I _{S(leak)}				30	μA
Forward voltage	V _{SF}	I _{OUT} = 400mA			1.7	V

*1 The thermal protection function is a feature to prevent the product from smoking and firing under unusual conditions. It is not intended to guarantee operation of the product under an ambient temperature exceeding the operating temperature range.

*2 Design guarantee is not tested in individual units.

Package Dimensions

unit : mm (typ)

3426A

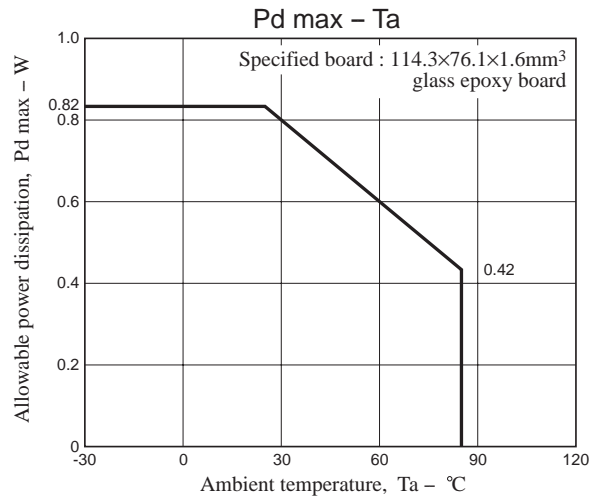
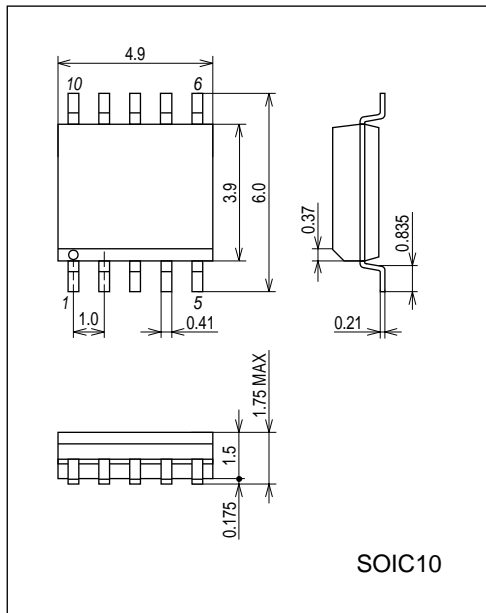

LB1909MC

Pin Assignment

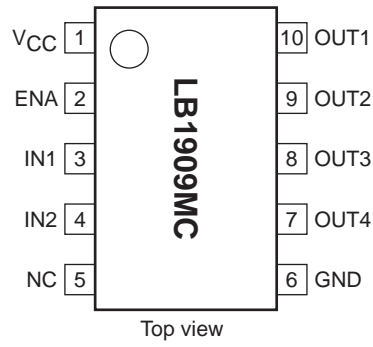

Truth table

Input			Output				Remarks	
ENA	IN1	IN2	OUT1	OUT2	OUT3	OUT4		
L	x	x	OFF	OFF	OFF	OFF	Standby mode	
H	L		H	L			Channel 1	Forward
	H		L	H				Reverse
		L			H	L	Channel 2	Forward
		H			L	H		Reverse

Block Diagram

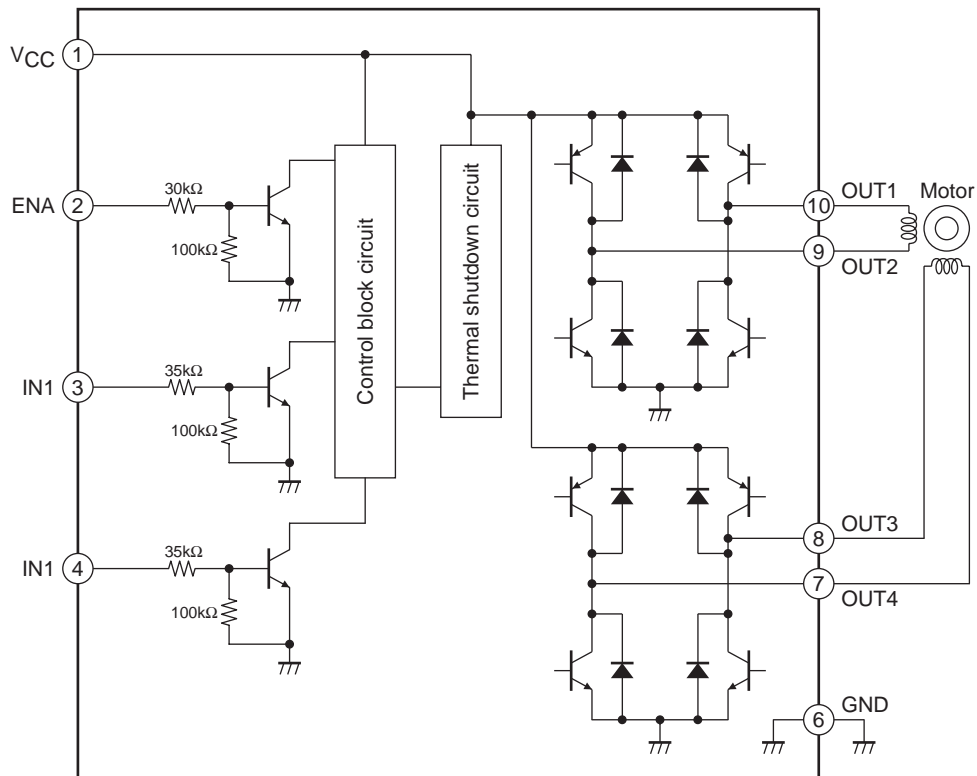

LB1909MC

Timing Chart (2 phase excitation drive)

