

500mA, 5.5V, Ultra Low Dropout Linear Regulator

General Description

The RT9081A is a high performance positive voltage regulator with separated bias voltage (V_{BIAS}), designed for applications requiring low input voltage and ultra low dropout voltage, output current up to 500mA. The feature of ultra low dropout voltage is ideal for applications where output voltage is very close to input voltage. The input voltage can be as low as 0.8V and the output voltage is adjustable by an external resistive divider. The RT9081A features very low quiescent current consumption for portable applications. The device is available in the ZADFN-6L 1.2x1.2 package.

Pin Configuration

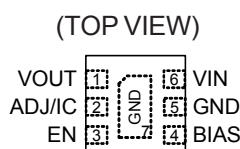

ZADFN-6L 1.2x1.2

Features

- Input Voltage Range : 0.8V to 5.5V
- Bias Voltage Range : 2.4V to 5.5V
- Output Voltage Fixed and Adjustable Versions
 - 0.9V to 1.8V (Fixed)
 - 0.8V to 3.6V (Adjustable)
- Accurate Output Voltage Accuracy (1.5%) Over Line, Load @ 25°C
- Ultra Low Dropout Voltage : 140mV at 500mA
- Low Bias Input Current
 - 80μA in Operating Mode
 - 0.5μA in Shutdown Mode
- Enable Control
- Output Active Discharge Function
- RoHS Compliant and Halogen Free

Applications

- Battery Powered Systems
- Portable Electronic Device
- Digital Set Top Boxes

Ordering Information

Product No.	Nominal Output Voltage	Package	Lead Plating System	Pin 1 Orientation
RT9081A-09GQZA(2)	0.90V	ZADFN-6L 1.2x1.2 (Z-Type)	G : Green (Halogen Free and Pb Free)	(2): Quadrant 2 Follow EIA-481-D ***Empty means Pin1 orientation is Quadrant 1
RT9081A-10GQZA	1.00V			
RT9081A-1KGQZA	1.05V			
RT9081A-11GQZA	1.10V			
RT9081A-1AGQZA(2)	1.15V			
RT9081A-12GQZA	1.20V			
RT9081A-1BGQZA(2)	1.25V			
RT9081A-13GQZA(2)	1.30V			
RT9081A-15GQZA(2)	1.50V			
RT9081A-18GQZA(2)	1.80V			
RT9081AGQZA(2)	Adjustable			

RT9081A

Marking Information

For marking information, contact our sales representative directly or through a Richtek distributor located in your area.

Typical Application Circuit

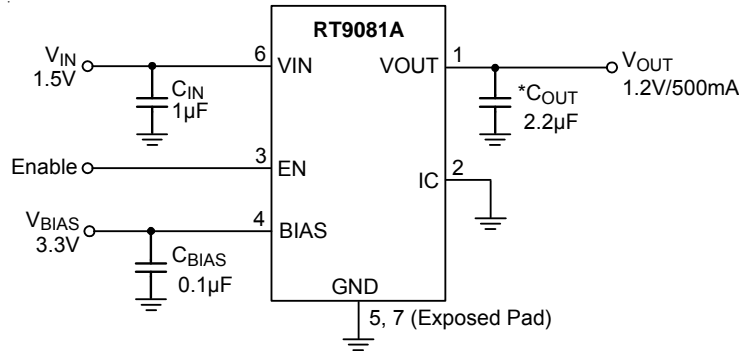

Figure 1. Fixed Voltage Regulator

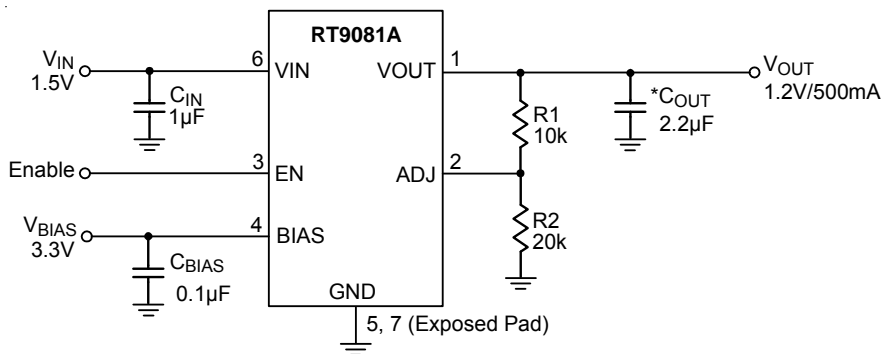

Figure 2. Adjustable Voltage Regulator

Table 1. Recommended External components

Component	Description	Vendor P/N
C _{BIAS}	0.1µF, 16V, X5R, 0402	CGA2B2X5R1C104M050BA (TDK) GRM155R61C104MA88J (Murata)
C _{IN}	1µF, 10V, X5R, 0402	GRM155R61A105KE15 (Murata)
*C _{OUT}	2.2µF, 6.3V, X5R, 0402	GRM153R60J225ME95 (Murata) C1005X5R0J225M050BC (TDK)
	4.7µF, 6.3V, X5R, 0402	GRM155R60J475ME47 (Murata) C1005X5R0J475M050BC (TDK)

Table 2. Suggested Component Values

V _{OUT} (V)	R1 (kΩ)	R2 (kΩ)	* C _{OUT} (µF)
1.2	10	20	2.2
1.8	10	8	2.2
2.5	10	4.7	4.7
3.3	10	3.16	4.7

* : Considering the effective capacitance derated with biased voltage level, the C_{OUT} component needs satisfy the effective capacitance at least 1µF or above at targeted output level for stable and normal operation.

Functional Pin Description

Pin No.	Pin Name	Pin Function
1	VOUT	Regulator output pin. Output capacitor should be placed directly at this pin.
2 (Fixed)	IC	Test pin. Internal pull down by 2 μ A. This pin should be floating or connected to ground.
2 (Adj)	ADJ	Adjustable output voltage feedback input pin.
3	EN	Chip enable pin. Pulling this pin below 0.54V turns the regulator off, reducing the quiescent current to a fraction of its operating value.
4	BIAS	Power supply input pin for the LDO control circuit. Mandatory to power up V _{BIAS} before V _{EN} and V _{IN} for the output soft start procedure works intended.
5, 7 (Expose pad)	GND	Ground. The exposed pad must be soldered to a large PCB and connected to GND for maximum power dissipation.
6	VIN	Regulator input pin. Input capacitor should be placed directly at this pin.

Functional Block Diagram

V_{OUT} Fixed Version

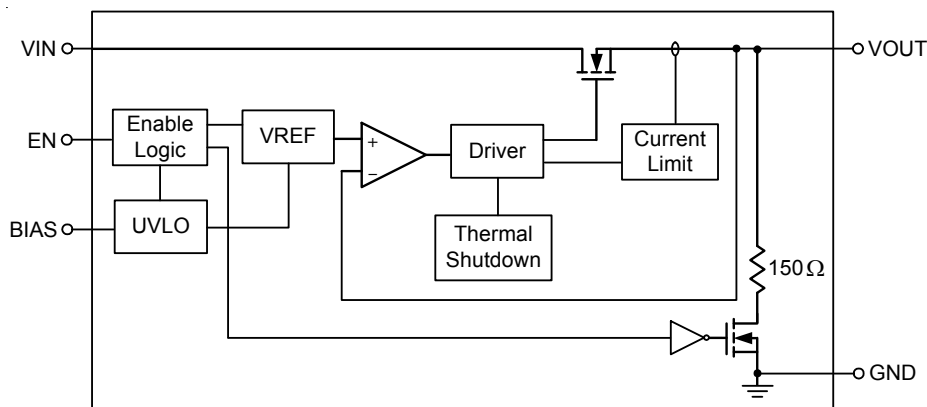

V_{OUT} Adjustable Version

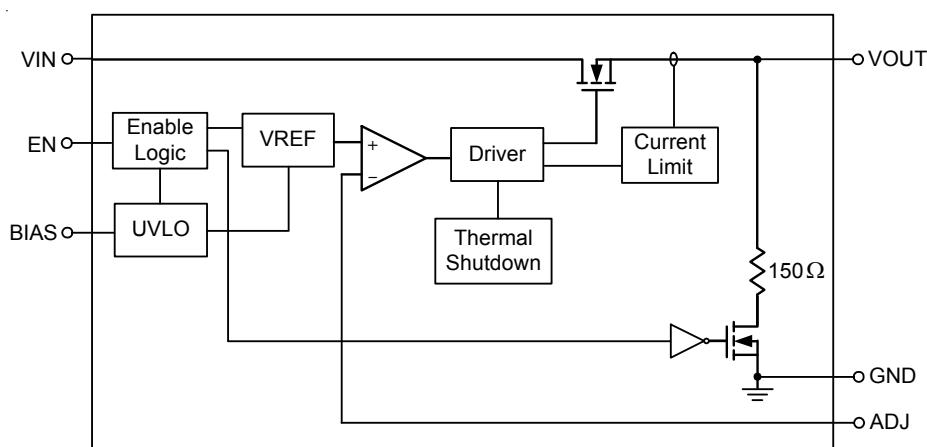

RT9081A

Operation

The RT9081A is using N-MOSFET pass transistor for output voltage regulation from VIN voltage. The separated bias voltage (V_{BIAS}) power the low current internal control circuit for applications requiring low input voltage and ultra low dropout voltage.

In steady-state operation, the feedback voltage is regulated to the reference voltage by the internal regulator. When the feedback voltage signal is less than the reference, the output current passes through the power MOSFET will be increased. The extra amount of the current is sent to the output until the voltage level of FB pin returns to the reference. On the other hand, if the feedback voltage is higher than the reference, the power MOSFET current is decreased. The excess charge at the output can be released by the loading current.

Chip Enable and Shutdown

The RT9081A provides an EN pin, as an external chip enable control, to enable or disable the device. V_{EN} below 0.54V turns the regulator off and enters the shutdown mode, while V_{EN} above 0.88V turns the regulator on. When the regulator is shutdown, the ground current is reduced to a maximum of 1 μ A.

Output Active Discharge

When the RT9081A is operating at shutdown mode, the device has an internal active pull down circuit that connects the output to GND through a 150 Ω resistor for output discharging purpose.

Current Limit

The RT9081A continuously monitors the output current to protect the pass transistor against abnormal operations. When an overload or short circuit is encountered, the current limit circuitry controls the pass transistor's gate voltage to limit the output within the predefined range.

Over-Temperature Protection (OTP)

The RT9081A has an over-temperature protection. When the device triggers the OTP, the device shuts down until the temperature back to normal state.

Absolute Maximum Ratings (Note 1)

• Supply Input Voltage, V_{IN}	-----	-0.3V to 6V
• All Other Pins	-----	-0.3V to 6V
• Power Dissipation, $P_D @ T_A = 25^\circ\text{C}$		
ZADFN-6L 1.2x1.2	-----	0.73W
• Package Thermal Resistance (Note 2)		
ZADFN-6L 1.2x1.2, θ_{JA}	-----	136.5°C/W
ZADFN-6L 1.2x1.2, θ_{JC}	-----	0.98°C/W
• Junction Temperature	-----	150°C
• Lead Temperature (Soldering, 10 sec.)	-----	260°C
• Storage Temperature Range	-----	-65°C to 150°C
• ESD Susceptibility (Note 3)		
HBM (Human Body Model)	-----	2kV
CDM (Charged Device Model)	-----	1kV

Recommended Operating Conditions (Note 4)

• Supply Input Voltage, V_{IN}	-----	0.8V to 5.5V
• Supply Input Voltage, V_{BIAS}	-----	2.4V to 5.5V
• Junction Temperature Range	-----	-40°C to 125°C

Electrical Characteristics

($V_{BIAS} \geq 2.4\text{V}$ and $V_{BIAS} \geq V_{OUT} + 1.6\text{V}$, $V_{IN} = V_{OUT(NOM)} + 0.3\text{V}$, $I_{OUT} = 1\text{mA}$, $V_{EN} = 1\text{V}$, $C_{IN} = 1\mu\text{F}$, $C_{OUT} = 2.2\mu\text{F}$, $T_A = 25^\circ\text{C}$, unless otherwise specified). (Note 6)

Parameter	Symbol	Test Conditions	Min	Typ	Max	Unit
Operating Input Voltage Range	V_{IN}		0.8	--	5.5	V
Operating Bias Voltage Range	V_{BIAS}		2.4	--	5.5	V
Under Voltage Lock-Out	V_{UVLO}	V_{BIAS} rising	--	1.6	--	V
		Hysteresis	--	0.2	--	V
Reference Voltage (Adj devices only)	V_{REF}		--	0.8	--	V
Output Voltage Accuracy	V_{OUT}	$V_{OUT} = 0.8\text{V}$, no load	-0.5	--	0.5	%
Output Voltage Accuracy (Note 5)	V_{OUT}	1. $V_{OUT(NOM)} + 0.3\text{V} \leq V_{IN} \leq V_{OUT(NOM)} + 1\text{V}$ 2. $V_{BIAS} \geq 2.4\text{V}$ and $V_{OUT(NOM)} + 1.6\text{V} \leq V_{BIAS} \leq 5.5\text{V}$ 3. $1\text{mA} \leq I_{OUT} \leq 500\text{mA}$	-1.5	--	1.5	%
V_{IN} Line Regulation	ΔV_{LINE_VIN}	$V_{OUT(NOM)} + 0.3\text{V} \leq V_{IN} \leq 5\text{V}$	--	0.01	--	%/V
V_{BIAS} Line Regulation	ΔV_{LINE_BIAS}	$V_{BIAS} \geq 2.4\text{V}$ and $V_{OUT(NOM)} + 1.6\text{V} \leq V_{BIAS} \leq 5.5\text{V}$	--	0.01	--	%/V

RT9081A

Parameter	Symbol	Test Conditions	Min	Typ	Max	Unit
Load Regulation	ΔV_{LOAD}	$I_{OUT} = 1mA \text{ to } 500mA$	--	1.5	--	mV
VIN Dropout Voltage	V_{DROP_VIN}	$I_{OUT} = 150mA$ (Note 7)	--	37	75	mV
		$I_{OUT} = 500mA$ (Note 7)	--	140	250	mV
VBIAS Dropout Voltage	V_{DROP_BIAS}	$I_{OUT} = 500mA, V_{IN} = V_{BIAS}$ (Note 7, Note 8)	--	1.1	1.5	V
Output Current Limit	I_{LIM}	$V_{OUT} = 90\% \text{ of } V_{OUT(NOM)}$	600	800	1000	mA
ADJ Pin Operating Current (ADJ devices only)	I_{ADJ}		--	0.1	0.5	μA
Bias Pin Operating Current	I_{BIAS}	$V_{BIAS} = 2.7V$	--	80	110	μA
Bias Pin Shutdown Current	$I_{BIAS(DIS)}$	$V_{EN} \leq 0.4V$	--	0.5	1	μA
VIN Pin Shutdown Current	$I_{VIN(DIS)}$	$V_{EN} \leq 0.4V$	--	0.5	1	μA
Enable Threshold Voltage	H-Level	V_{ENH}	0.68	0.78	0.88	V
	L-Level	V_{ENL}	0.54	0.65	0.75	
EN Pull Down Current	I_{EN}	$V_{EN} = 5.5V, V_{BIAS} = 5.5V$	--	1	--	μA
Turn-On Time	t_{ON}	From assertion of V_{EN} to $V_{OUT} = 90\% \text{ of } V_{OUT(NOM)}$, $V_{OUT(NOM)} = 1V$	--	150	--	μs
Power Supply Rejection Ratio	$PSRR_{VIN}$	V_{IN} to V_{OUT} , $f = 1kHz$, $I_{OUT} = 150mA, V_{IN} \geq V_{OUT} + 0.5V$	--	70	--	dB
	$PSRR_{VBIAS}$	V_{BIAS} to V_{OUT} , $f = 1kHz$, $I_{OUT} = 150mA, V_{IN} \geq V_{OUT} + 0.5V$	--	80	--	dB
Output Noise Voltage (Fixed Volt.)	e_{NO_FIXED}	$V_{IN} = V_{OUT} + 0.5V, V_{OUT(NOM)} = 1V$, $f = 10Hz \text{ to } 100kHz$	--	40	--	μV_{RMS}
Output Noise Voltage (Adj devices)	e_{NO_ADJ}	$V_{IN} = V_{OUT} + 0.5V, f = 10Hz \text{ to } 100kHz$	--	$50 \times V_{OUT}$	--	μV_{RMS}
Thermal Shutdown Threshold		Temperature increasing	--	160	--	$^{\circ}C$
		Temperature decreasing	--	140	--	$^{\circ}C$
Output Discharge Pull-Down	R_{DISCHG}	$V_{EN} \leq 0.4V, V_{OUT} = 0.5V$	--	150	--	Ω

- Note 1.** Stresses beyond those listed under “Absolute Maximum Ratings” may cause permanent damage to the device. These are stress ratings only, and functional operation of the device at these or any other conditions beyond those indicated in the operational sections of the specifications is not implied. Exposure to absolute maximum rating conditions may affect device reliability.
- Note 2.** θ_{JA} is measured under natural convection (still air) at $T_A = 25^\circ\text{C}$ with the component mounted on a two-layer Richtek Evaluation Board.
- Note 3.** Devices are ESD sensitive. Handling precaution is recommended.
- Note 4.** The device is not guaranteed to function outside its operating conditions.
- Note 5.** Adjustable devices tested at 0.8V; external resistor tolerance is not taken into account.
- Note 6.** Performance guaranteed over the indicated operating temperature range by design and/or characterization. Production tested at $T_A = 25^\circ\text{C}$. Low duty cycle pulse techniques are used during the testing to maintain the junction temperature as close to ambient as possible.
- Note 7.** Dropout voltage is characterized when V_{OUT} falls 3% below $V_{OUT(\text{Normal})}$.
- Note 8.** For output voltages below 0.9V, V_{BIAS} dropout voltage does not apply due to a minimum Bias operating voltage of 2.4V.

Typical Operating Characteristics

BIAS Voltage UVLO vs. Temperature

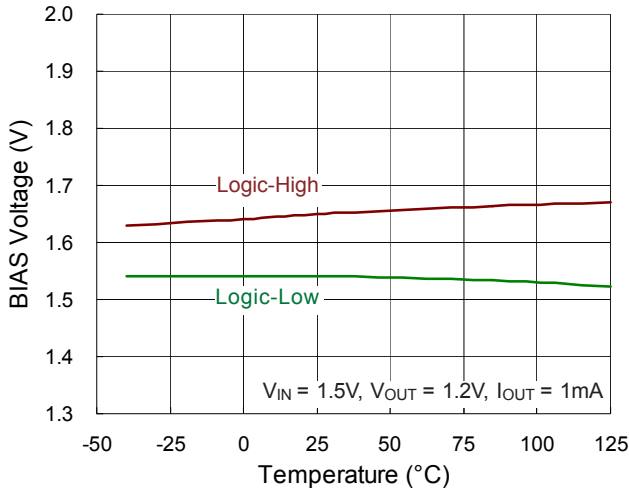

Enable Voltage Threshold vs. Temperature

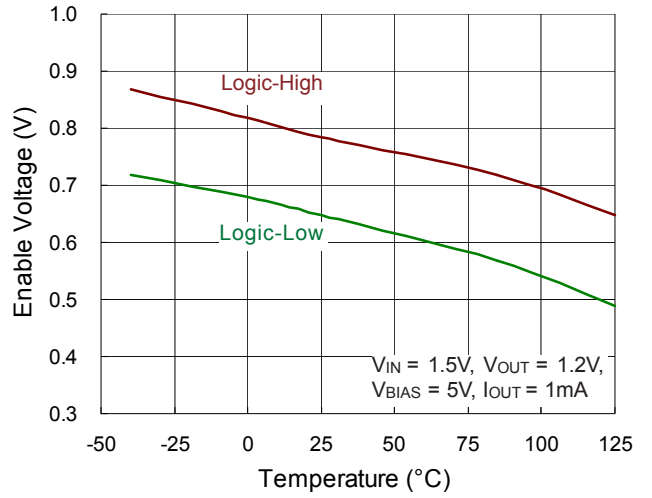

Reference Voltage vs. Temperature

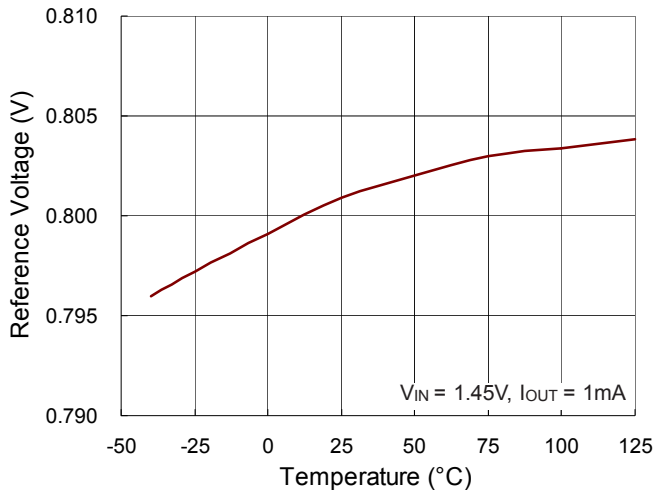

V_{IN} Dropout Voltage vs. (V_{BIAS} - V_{OUT})

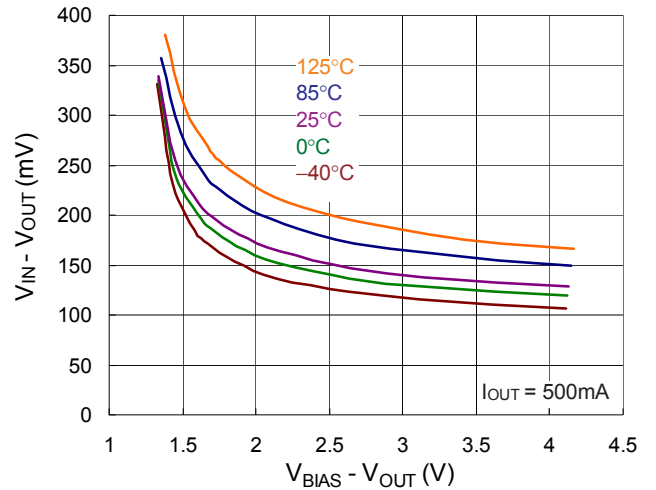

Dropout Voltage vs. Output Current

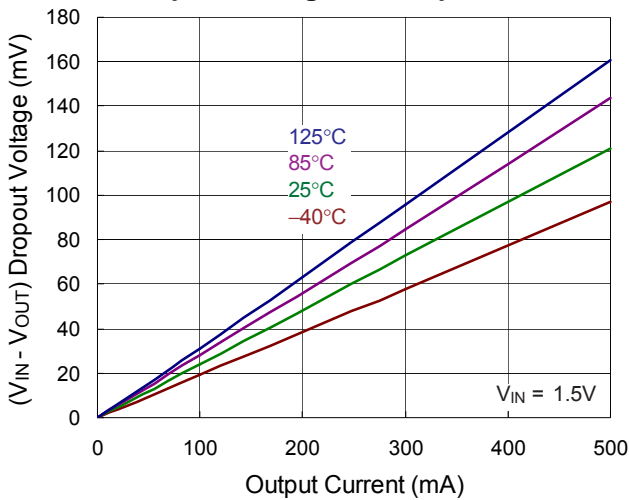

Output Spectral Noise Density

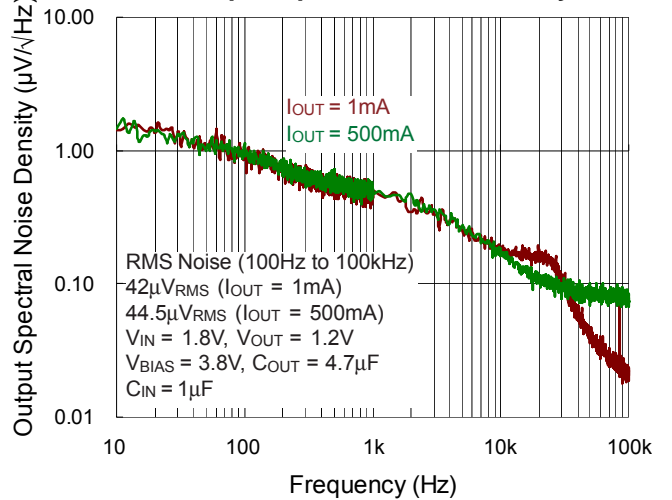

Power On from EN

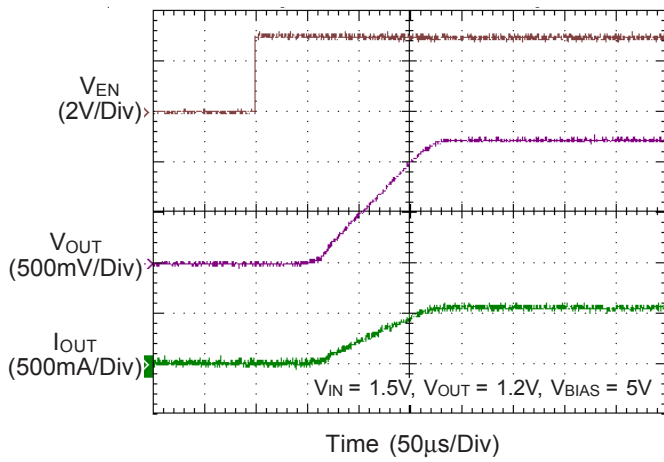

Power Off from EN

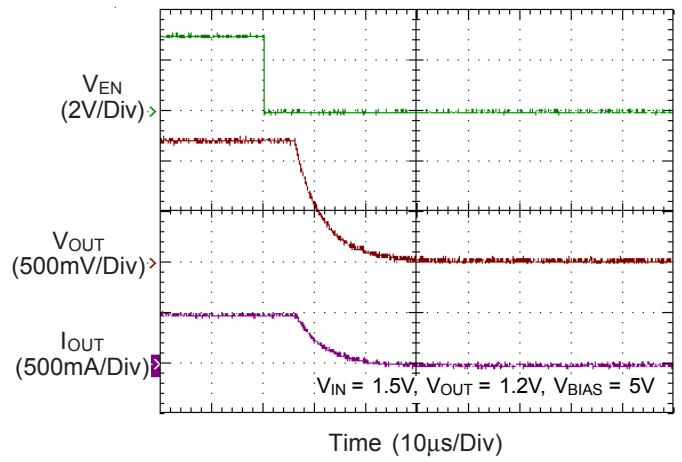

Output Current Limit Protection

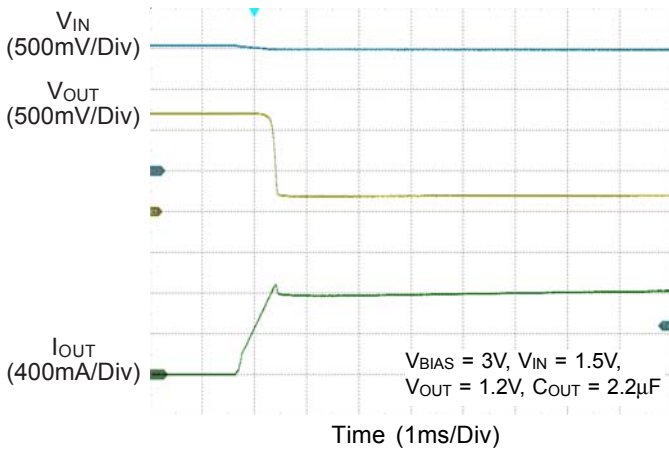

RT9081A

Application Information

The RT9081A is a low voltage, low dropout linear regulator with input voltage V_{IN} from 0.8V to 5.5V, V_{BIAS} from 2.4V to 5.5V and adjusted output voltage from 0.8V to $(V_{IN} - V_{DROP})$.

Output Voltage Setting

For the RT9081A, the voltage on the ADJ pin sets the output voltage and is determined by the values of R1 and R2. The values of R1 and R2 can be calculated for any voltage using the formula given in Equation :

$$V_{OUT} = 0.8V \times \left(\frac{R1 + R2}{R2} \right)$$

Using lower values for R1 and R2 is recommended to reduce the noise injected from the FB pin. Note that R1 is connected from VOUT pin to ADJ pin, and R2 is connected from ADJ to GND.

BIAS Pin Input

The V_{BIAS} supply rail that powers the LDO control circuit sinks very low current (approximately the quiescent current of the LDO), which must be higher than 2.4V and higher than the output voltage of 1.6V for normal operation.

Dropout Voltage

The dropout voltage refers to the voltage difference between the V_{IN} and V_{OUT} pins while operating at specific output current. The dropout voltage V_{DROP} also can be expressed as the voltage drop on the pass-FET at specific output current (I_{RATED}) while the pass-FET is fully operating at ohmic region and the pass-FET can be characterized as an resistance $R_{DS(ON)}$. Thus the dropout voltage can be defined as ($V_{DROP} = V_{IN} - V_{OUT} = R_{DS(ON)} \times I_{RATED}$). For normal operation, the suggested LDO operating range is ($V_{IN} > V_{OUT} + V_{DROP}$) for good transient response and PSRR ability. Vice versa, while operating at the ohmic region will degrade the performance severely.

C_{IN} and C_{OUT} Selection

The RT9081A is designed specifically to work with low ESR ceramic output capacitor for space saving and performance consideration. Using a ceramic capacitor with capacitance range from 1 μ F (Effective value) to 10 μ F on the RT9081A output ensures stability. The input capacitor

must be located at a distance of no more than 0.5 inch from the input pin of the chip. However, a capacitor with larger value and lower ESR (Equivalent Series Resistance) is recommended since it will provide better PSRR and line transient response. Any good quality ceramic capacitor can be used, $C_{IN} = 1\mu F$ and $C_{BIAS} = 0.1\mu F$ or greater are recommended.

Sequencing Requirements

The RT9081A supports power on the input V_{IN} , V_{BIAS} , and EN pins in any order without damage the device. However, for the output soft start procedure works as intended, it is mandatory to ensure $V_{BIAS} \geq V_{OUT} + 1.6V$ before $V_{IN} \geq V_{OUT} + 0.3V$, the device enabled by V_{EN} ($V_{EN} > V_{ENH}$) eventually. The BIAS pin supplies voltage for the LDO control circuit, and powering up V_{BIAS} first will ensure turn on time (t_{ON}) and output voltage accuracy to follow datasheet spec.

Thermal Considerations

The junction temperature should never exceed the absolute maximum junction temperature $T_{J(MAX)}$, listed under Absolute Maximum Ratings, to avoid permanent damage to the device. The maximum allowable power dissipation depends on the thermal resistance of the IC package, the PCB layout, the rate of surrounding airflow, and the difference between the junction and ambient temperatures. The maximum power dissipation can be calculated using the following formula :

$$P_{D(MAX)} = (T_{J(MAX)} - T_A) / \theta_{JA}$$

where $T_{J(MAX)}$ is the maximum junction temperature, T_A is the ambient temperature, and θ_{JA} is the junction-to-ambient thermal resistance.

For continuous operation, the maximum operating junction temperature indicated under Recommended Operating Conditions is 125°C. The junction-to-ambient thermal resistance, θ_{JA} , is highly package dependent. For a ZADFN-6L 1.2x1.2 package, the thermal resistance, θ_{JA} , is 136.5°C/W on a two-layer Richtek evaluation board. The maximum power dissipation at $T_A = 25^\circ C$ can be calculated as below :

$P_{D(MAX)} = (125^{\circ}\text{C} - 25^{\circ}\text{C}) / (136.5^{\circ}\text{C}/\text{W}) = 0.73\text{W}$ for a ZADFN-6L 1.2x1.2 package.

The maximum power dissipation depends on the operating ambient temperature for the fixed $T_{J(MAX)}$ and the thermal resistance, θ_{JA} . The derating curves in Figure 1 allows the designer to see the effect of rising ambient temperature on the maximum power dissipation.

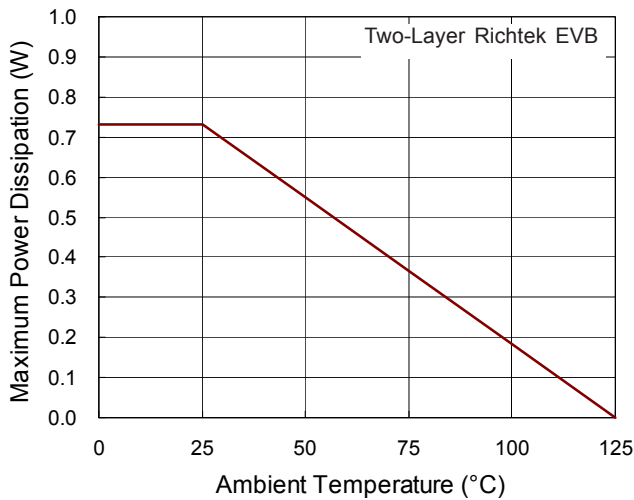

Figure 3. Derating Curve of Maximum Power Dissipation

Layout Considerations

For best performance of the RT9081A, the PCB layout suggestions below are highly recommend.

- ▶ All circuit components placed on the same side and as near to the respective LDO pin as possible, place the ground return path connection to the input and output capacitor.
- ▶ The ground plane connected by a wide copper surface for good thermal dissipation.
- ▶ Using vias and long power traces for the input and output capacitors connection is discouraged and have negatively affects on performance.

Figure 4 shows an example for the layout reference that reduce conduction trace loop, helping inductive parasitic minimize, load transient reduction and good circuit stability.

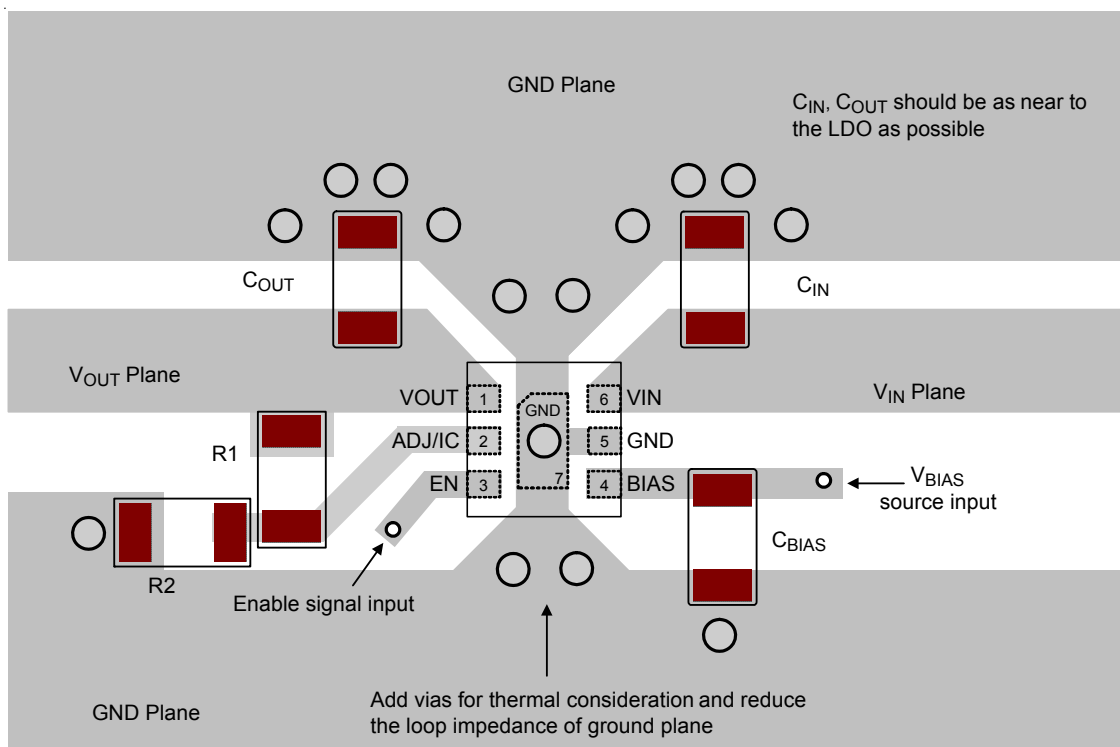
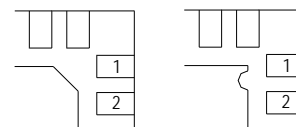
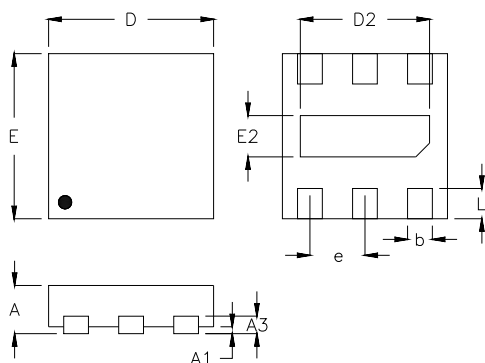

Figure 4. PCB Layout Guide

RT9081A

Outline Dimension



DETAIL A

Pin #1 ID and Tie Bar Mark Options

Note : The configuration of the Pin #1 identifier is optional, but must be located within the zone indicated.

Symbol	Dimensions In Millimeters		Dimensions In Inches	
	Min.	Max.	Min.	Max.
A	0.280	0.320	0.011	0.013
A1	0.000	0.010	0.000	0.000
A3	0.060		0.002	
b	0.130	0.230	0.005	0.009
D	1.100	1.300	0.043	0.051
D2	0.990	1.040	0.039	0.041
E	1.100	1.300	0.043	0.051
E2	0.350	0.400	0.014	0.016
e	0.400		0.016	
L	0.170	0.270	0.007	0.011

Z-Type 6L ADFN 1.2x1.2 Package

Footprint Information

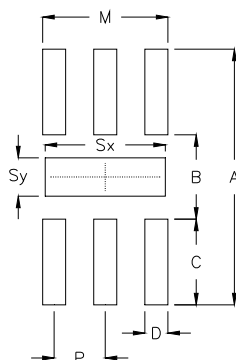

Package	Number of Pin	Footprint Dimension (mm)								Tolerance
		P	A	B	C	D	Sx	Sy	M	
U/X/ZADFN1.2*1.2-6	6	0.400	2.000	0.760	0.620	0.180	1.015	0.375	0.980	±0.050