

MPQ2019

40V, 300mA, Low-Quiescent Current Adjustable Output Linear Regulator AEC-Q100 Qualified

DESCRIPTION

The MPQ2019 is a low-power linear regulator that supplies power to systems with high-voltage batteries. It includes a wide 3V to 40V input range, low-dropout voltage and low-quiescent supply current. The low-quiescent current and low-dropout voltage allow operations at extremely low-power levels. Therefore, the MPQ2019 is ideal for low-power microcontrollers and battery-powered equipment.

The MPQ2019 provides a wide variety of fixed output-voltage options (if requested): 1.8V, 1.9V, 2.3V, 2.5V, 3.0V, 3.3V, 3.45V, and 5.0V; Also it provides the output-adjustable option (from 1.25V to 15V).

The regulator output current is limited internally, and the device is protected against short-circuit, over-load, and over-temperature conditions.

The MPQ2019 includes thermal shutdown (TSD), current-limiting fault protection, and is available in a SOIC-8 EP package.

FEATURES

- 3V to 40V Input Range
- 10 μ A Quiescent Supply Current
- Stable with Low-value Output Ceramic Capacitor ($> 0.47\mu$ F)
- 300mA Specified Current
- Fixed 5V, 3.3V, and Adjustable Output (1.2 V to 15 V) Versions
- Output $\pm 2\%$ Accuracy Over Temperature
- Specified Current Limit
- Power Good
- Programmable Power Good Delay
- Thermal Shutdown and Short-Circuit Protection
- -40°C to $+150^{\circ}\text{C}$ Specified Junction Temperature Range
- Available in a SOIC-8 EP Packages
- Available in AEC-Q100 Grade 1

APPLICATIONS

- Industrial/Automotive Applications
- Portable/Battery-Powered Equipment
- Ultra Low-Power Microcontrollers
- Cellular Handsets
- Medical Imaging

All MPS parts are lead-free, halogen free, and adhere to the RoHS directive. For MPS green status, please visit MPS website under Quality Assurance. "MPS" and "The Future of Analog IC Technology" are Registered Trademarks of Monolithic Power Systems, Inc.

TYPICAL APPLICATION

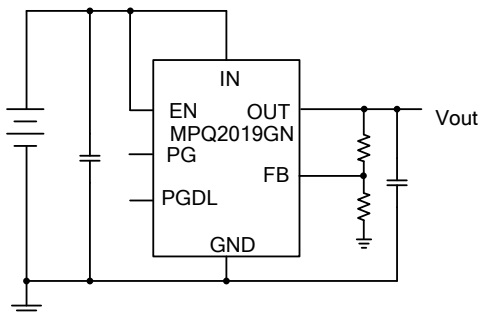

Output Adjustable Version

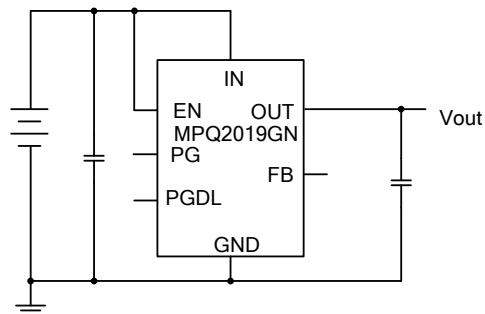

Output Fixed Version

ORDERING INFORMATION

Part Number*	Package	Top Marking
MPQ2019GN	SOIC8-EP	<i>See Below</i>
MPQ2019GN-33	SOIC8-EP	
MPQ2019GN-5	SOIC8-EP	
MPQ2019GN-AEC1	SOIC8-EP	
MPQ2019GN-33-AEC1	SOIC8-EP	
MPQ2019GN-5-AEC1	SOIC8-EP	

* For Tape & Reel, add suffix -Z (e.g. MPQ2019GN-Z)

TOP MARKING

MP2019
LLLLLLLL
MPSYWW

MP2019: part code of MPQ2019GN;
LLLLLLLL: lot number;
MPS: MPS prefix;
Y: year code;
WW: week code:

TOP MARKING

M2019-33
LLLLLLLL
MPSYWW

MP2019-33: part code of MPQ2019GN-33
LLLLLLLL: lot number;
MPS: MPS prefix;
Y: year code;
WW: week code:

TOP MARKING

MP2019-5
LLLLLLLL
MPSYWW

MP2019-5: part code of MPQ2019GN-5
LLLLLLLL: lot number;
MPS: MPS prefix;
Y: year code;
WW: week code:

PACKAGE REFERENCE

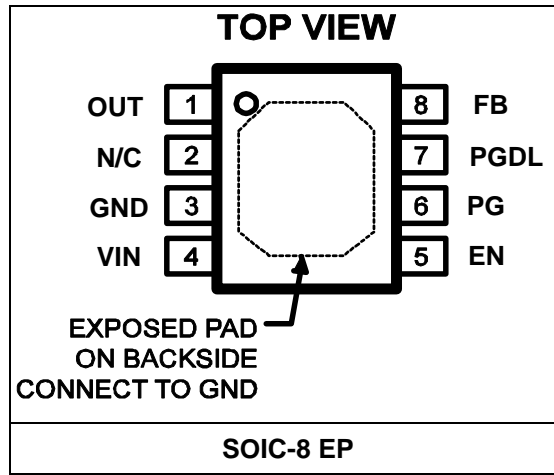

ABSOLUTE MAXIMUM RATINGS ⁽¹⁾

IN, EN.....	-0.3V to +42V
OUT.....	-0.3V to +17V
PG	-0.3V to +15V
PGDL, FB.....	-0.3V to +6V
Junction Temperature.....	+150°C
Lead Temperature	+260°C
Storage Temperature.....	-65°C to +150°C
Continuous Power Dissipation (T _A = +25°C) ⁽²⁾	
SOIC-8 EP.....	2.5W

ESD SUSCEPTIBILITY ⁽³⁾

HBM (Human Body Mode)	4kV
MM (Machine Mode).....	200V

Recommended Operating Conditions ⁽⁴⁾

Supply Voltage V _{IN}	3V to 40V
Output Voltage V _{OUT}	1.25V to 15V
Operating Temperature	T _A =-40°C to +125°C
	T _A ≤ T _J ≤ +150°C

Thermal Resistance ⁽⁵⁾	θ_{JA}	θ_{JC}
SOIC-8 EP.....	50	10 ...°C/W

Notes:

- 1) Exceeding these ratings may damage the device.
- 2) The maximum allowable power dissipation is a function of the maximum junction temperature T_J (MAX), the junction-to-ambient thermal resistance θ_{JA}, and the ambient temperature T_A. The maximum allowable continuous power dissipation at any ambient temperature is calculated by P_D (MAX) = (T_J (MAX) - T_A) / θ_{JA}. Exceeding the maximum allowable power dissipation produces an excessive die temperature, causing the regulator to go into thermal shutdown. Internal thermal shutdown circuitry protects the device from permanent damage.
- 3) Devices are ESD sensitive. Handle with precaution.
- 4) The device is not guaranteed to function outside of its operating conditions.
- 5) Measured on JESD51-7, 4-layer PCB.

ELECTRICAL CHARACTERISTICS

$V_{IN} = V_{EN} = 13.5V$, $T_A = -40^{\circ}C$ to $+125^{\circ}C$, $T_A \leq T_J \leq +150^{\circ}C$, unless otherwise noted. Typical values are at $T_A = +25^{\circ}C$.

Parameter	Symbol	Condition	Min	Typ	Max	Units	
Input Voltage	V_{IN}		3		40	V	
Output-Voltage Range	V_{OUT}		1.25		15	V	
GND Current	I_{GND}	MPQ2019GN	$0 < I_{LOAD} < 1mA$		10	15	μA
			$1mA < I_{LOAD} < 30mA$		15	21	
			$30mA < I_{LOAD} < 300mA$		65	95	
		MPQ2019GN-33	$0 < I_{LOAD} < 1mA$		12	16	μA
			$1mA < I_{LOAD} < 30mA$		16	22	
			$30mA < I_{LOAD} < 300mA$		65	95	
		MPQ2019GN-5	$0 < I_{LOAD} < 1mA$		12	16	μA
			$1mA < I_{LOAD} < 30mA$		16	22	
			$30mA < I_{LOAD} < 300mA$		65	95	
Shutdown Supply Current	I_S	$V_{EN} = 0V$			1	μA	
Load-Current Limit	I_{LIMIT}	$V_{IN} = 7V$, $V_{OUT} = 0V$, $T_A = +25^{\circ}C$	600	1000	1350	mA	
FB Voltage	V_{FB}	MPQ2019GN, FB = OUT, $I_{LOAD} = 5mA$	1.225	1.25	1.275	V	
Output Voltage Accuracy		MPQ2019GN-33, $I_{LOAD} = 5mA$	3.2	3.3	3.4	V	
		MPQ2019GN-5, $I_{LOAD} = 5mA$	4.85	5	5.15		
Dropout Voltage ⁽⁶⁾	$V_{DROPOUT}$	MPQ2019GN	$V_{OUT} = 5V$, $I_{LOAD} = 150mA$		200	400	mV
			$T_A = +25^{\circ}C$, $V_{OUT} = 5V$, $I_{LOAD} = 300mA$		420	550	
		MPQ2019GN-33	$V_{OUT} = 3.3V$, $I_{LOAD} = 150mA$		230	430	
			$T_A = +25^{\circ}C$, $V_{OUT} = 3.3V$, $I_{LOAD} = 300mA$		480	640	
		MPQ2019GN-5	$V_{OUT} = 5V$, $I_{LOAD} = 150mA$		230	430	
			$T_A = +25^{\circ}C$, $V_{OUT} = 5V$, $I_{LOAD} = 300mA$		480	640	
FB Input Current	I_{FB}	MPQ2019GN	$V_{FB} = 1.3V$		50	nA	
Line Regulation		MPQ2019GN	$V_{IN} = 3V$ to $40V$, $I_{LOAD} = 5mA$, $V_{OUT} = V_{FB}$	-10	1	10	mV
		MPQ2019GN-33	$V_{IN} = 5V$ to $40V$, $I_{LOAD} = 5mA$, $V_{OUT} = 3.3V$	-10	1	10	
		MPQ2019GN-5	$V_{IN} = 6V$ to $40V$, $I_{LOAD} = 5mA$, $V_{OUT} = 5V$	-10	1	10	

ELECTRICAL CHARACTERISTICS (continued)

$V_{IN} = V_{EN} = 13.5V$, $T_A = -40^{\circ}C$ to $+125^{\circ}C$, $T_A \leq T_J \leq +150^{\circ}C$, unless otherwise noted. Typical values are at $T_A = +25^{\circ}C$.

Parameter	Symbol	Condition	Min	Typ	Max	Units
Load Regulation		MPQ2019GN $I_{LOAD} = 5mA$ to $300mA$, $V_{OUT} = 5V, T_A = +25^{\circ}C$		1	15	mV
		MPQ2019GN-33 $I_{LOAD} = 5mA$ to $300mA$, $V_{OUT} = 3.3V, T_A = +25^{\circ}C$		1	15	
		MPQ2019GN-5 $I_{LOAD} = 5mA$ to $300mA$, $V_{OUT} = 5V, T_A = +25^{\circ}C$		1	15	
Output Voltage PSRR ⁽⁷⁾		100Hz, $C_{OUT} = 10\mu F$, $I_{LOAD} = 10mA$		57		dB
		1kHz, $C_{OUT} = 10\mu F$, $I_{LOAD} = 10mA$		45		
		100kHz, $C_{OUT} = 10\mu F$, $I_{LOAD} = 10mA$		51		
Start-Up Response Time		MPQ2019GN $R_{LOAD} = 500\Omega$, $V_{OUT} = 5V$, $C_{OUT} = 22\mu F$, V_{OUT} from 10% to 90%		0.9	1.5	ms
		MPQ2019GN-33 $R_{LOAD} = 500\Omega$, $V_{OUT} = 3.3V$, $C_{OUT} = 22\mu F$, V_{OUT} from 10% to 90%		0.5	1	
		MPQ2019GN-5 $R_{LOAD} = 500\Omega$, $V_{OUT} = 5V$, $C_{OUT} = 22\mu F$, V_{OUT} from 10% to 90%		0.9	1.5	
EN Threshold Voltage	V_{IL}				0.3	V
	V_{IH}		1.8			V
EN Input Current		EN = 0V or 15V		0.1	0.5	μA
PG Rising Threshold		MPQ2019GN	89%	93%	97%	V_{FB}
		MPQ2019GN-33	88%	92%	96%	
		MPQ2019GN-5	88%	92%	96%	
PG Rising Threshold Hysteresis				5%		V_{FB}
PG Low Voltage		Sink 1mA Current		0.1	0.4	V
PG Leakage Current		$V_{PG} = 5V$			1	μA
PGDL Charging Current		$V_{PGDL} = 1V$	3	5.5	9	μA
PGDL Rising Threshold			1.4	1.7	2	V
PGDL Falling Threshold			0.2	0.4	0.7	V
PG Delay Time		$C_{PGDL} = 47nF$	5	10	15	ms
PG Reaction Time		$C_{PGDL} = 47nF$		0.5	2	μs
Thermal Shutdown ⁽⁷⁾	T_{SD}			165		$^{\circ}C$
Thermal Shutdown Hysteresis ⁽⁷⁾	ΔT_{SD}			30		$^{\circ}C$

Notes:

6) Dropout Voltage: Measured when the output voltage V_{OUT} has dropped 100mV from the nominal value obtained at $V_{IN} = 13.5V$.

7) Derived from bench characterization. Not tested in production.

PIN FUNCTIONS

Pin #	Name	Description
1	OUT	Regulated Output Voltage. Only a low-value ceramic capacitor ($\geq 0.47\mu\text{F}$) on the output is required for stability.
2	NC	No Connection.
3	GND	Ground. Connect the exposed pad and GND to the same ground plane.
4	IN	Input Voltage. Connect a 3V to 40V supply to IN.
5	EN	Regulator On/Off Control Input. Logic low shuts down the IC; logic high starts up the IC. Connect EN to IN for automatic start-up.
6	PG	Power Good. If not used, pin can be left floating.
7	PGDL	Programmable Power-Good Delay Time. If not used, pin can be left floating.
8	FB	Feedback Input for Output Adjustable Version. FB is regulated to 1.25V nominally. This terminal is used to set the output voltage.

TYPICAL PERFORMANCE CHARACTERISTICS

Dropout Voltage vs. Junction Temperature

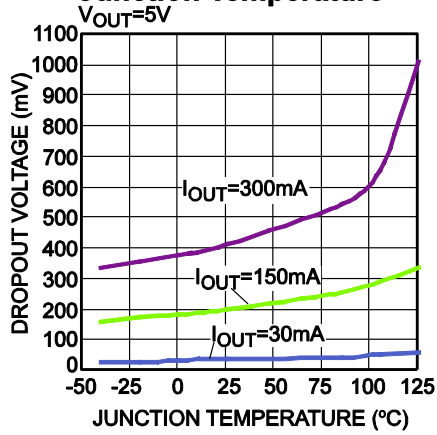

Feedback Voltage vs. Junction Temperature

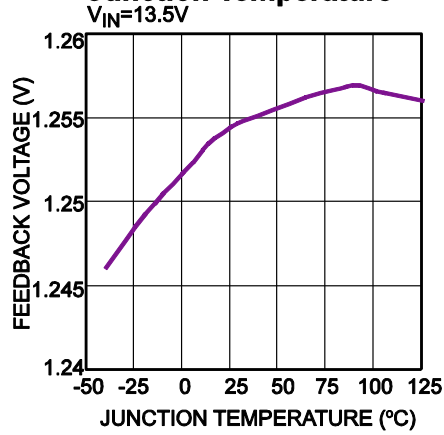

Current Limit vs. Junction Temperature

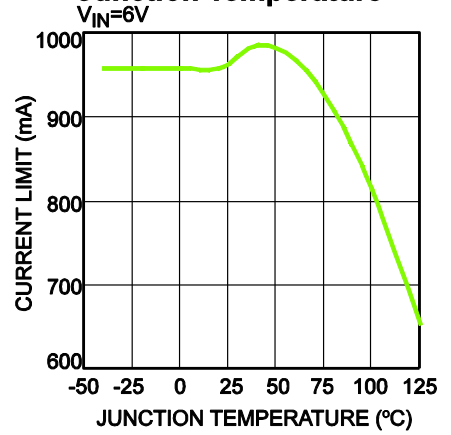

Shutdown Current vs. Junction Temperature

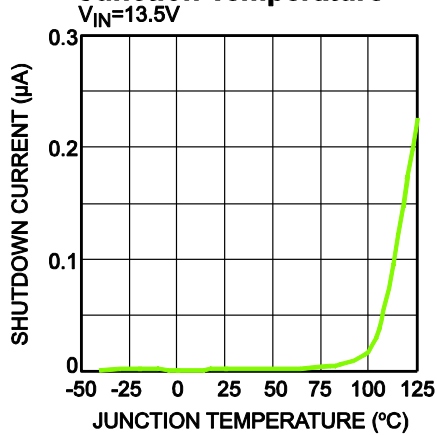

GND Current vs. Junction Temperature

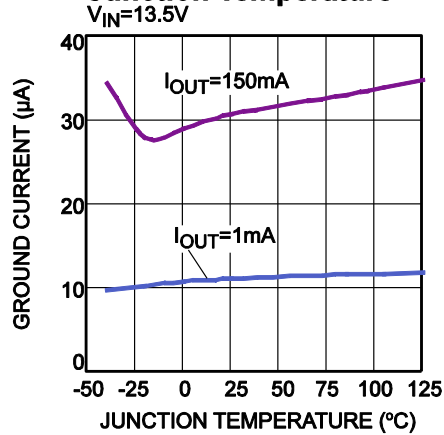

EN Threshold vs. Junction Temperature

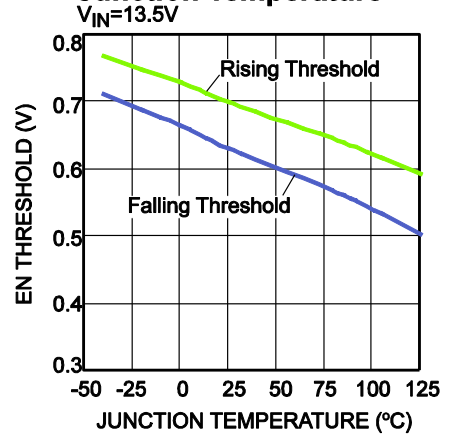

TYPICAL PERFORMANCE CHARACTERISTICS

$C_{IN} = 1\mu F$, $C_{OUT} = 22\mu F$, $V_{OUT} = 5V$, $T_A = 25^\circ C$, unless otherwise noted.

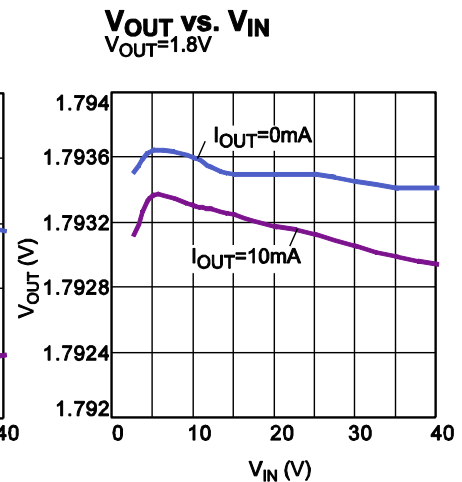
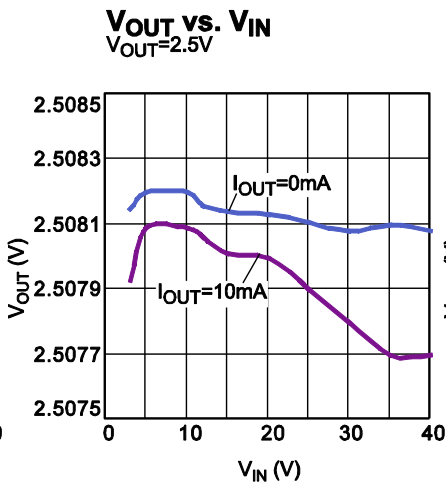
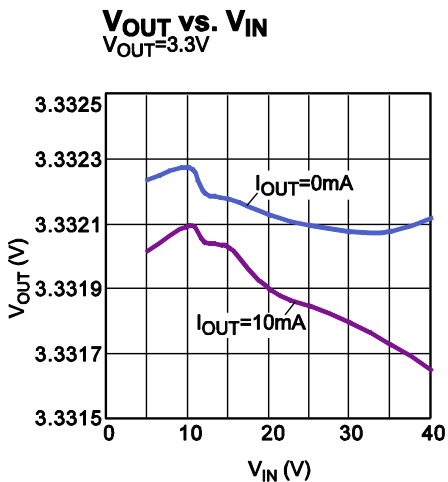
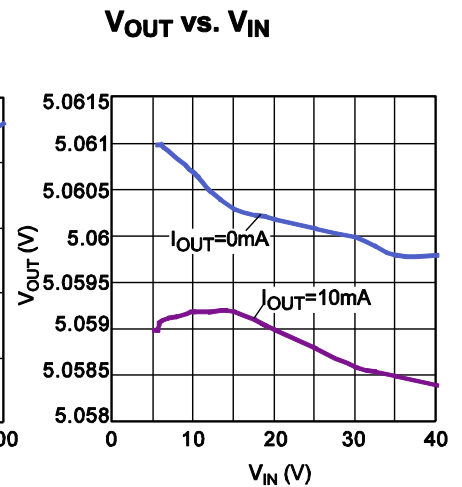
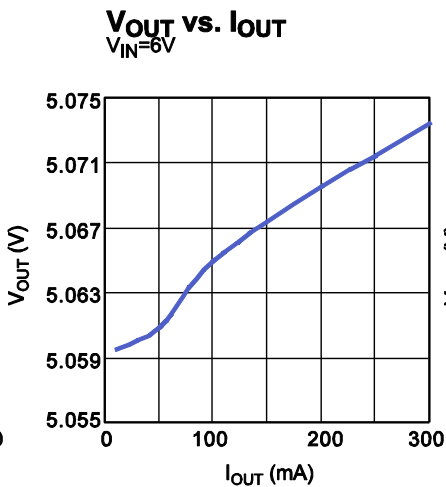
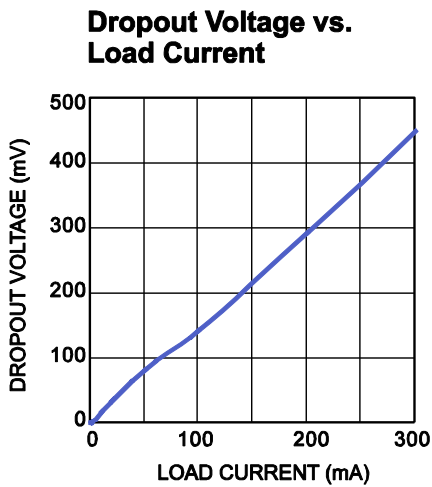
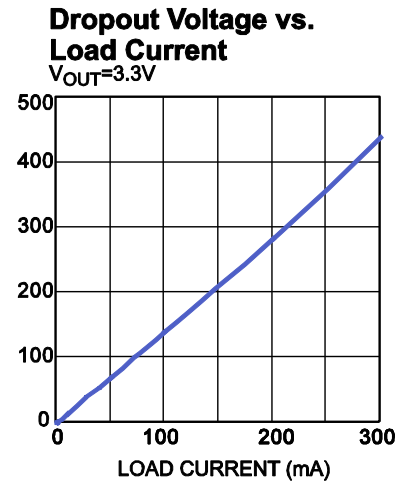
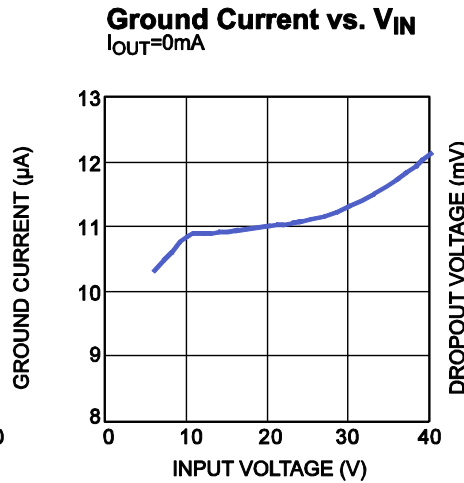
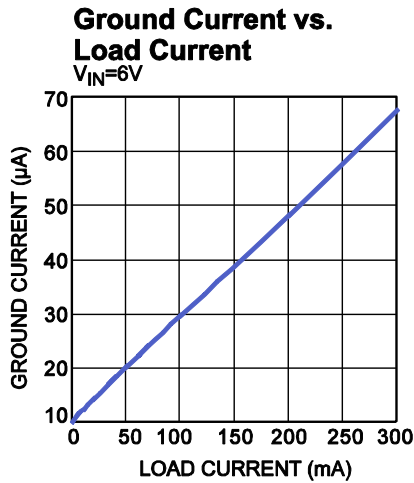

TYPICAL PERFORMANCE CHARACTERISTICS (continued)

$C_{IN} = 1\mu F$, $C_{OUT} = 22\mu F$, $V_{OUT} = 5V$, $T_A = 25^\circ C$, unless otherwise noted.

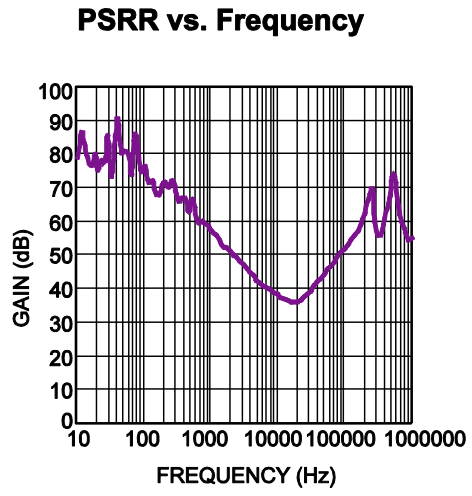
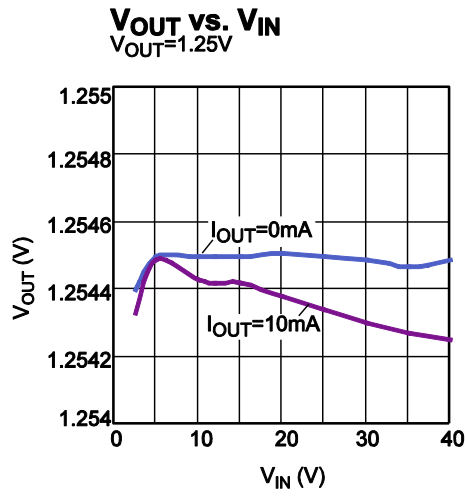

TYPICAL PERFORMANCE CHARACTERISTICS (continued)

$C_{IN} = 1\mu F$, $C_{OUT} = 22\mu F$, $V_{OUT} = 5V$, $T_A = 25^\circ C$, unless otherwise noted.

Load Transient

$V_{IN} = 12V$, $I_{OUT} = 300mA$

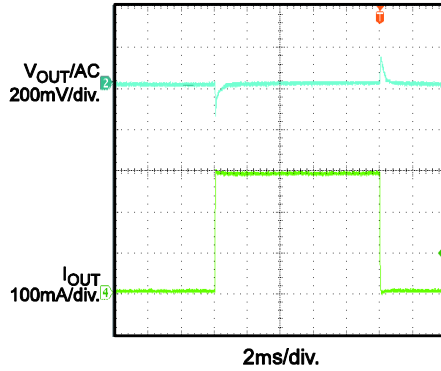

Line Transient

$V_{IN} = 6V-7V$, $I_{OUT} = 300mA$

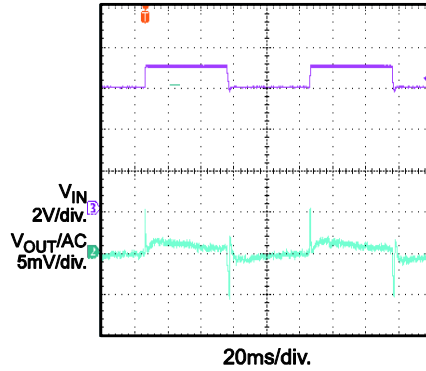

Start-Up through V_{IN}

$V_{IN} = 12V$, $I_{OUT} = 300mA$

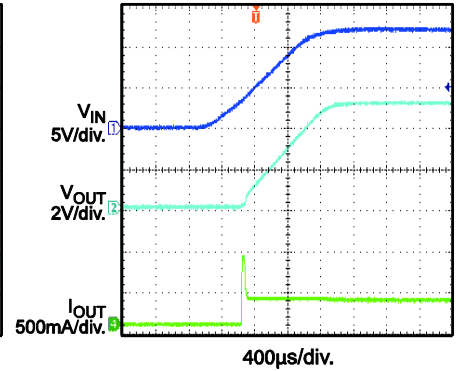

Shutdown through V_{IN}

$V_{IN} = 12V$, $I_{OUT} = 300mA$

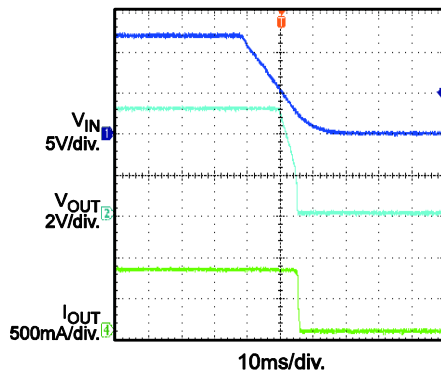

Short-Circuit Entry

$V_{IN} = 12V$,
 $I_{OUT} = 0mA$ to short circuit

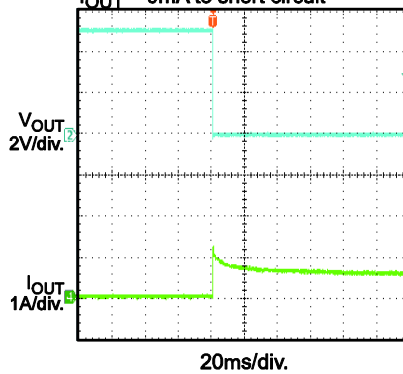

Short-Circuit Recovery

$V_{IN} = 12V$,
short circuit to $I_{OUT} = 0mA$

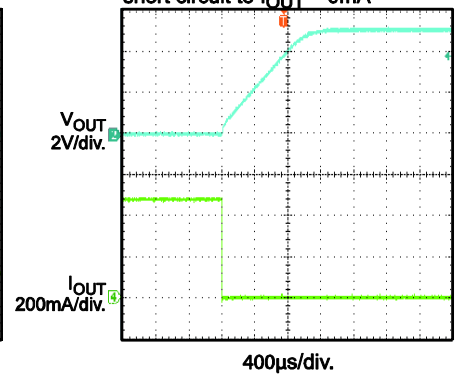

Short-Circuit Steady State

$V_{IN} = 12V$

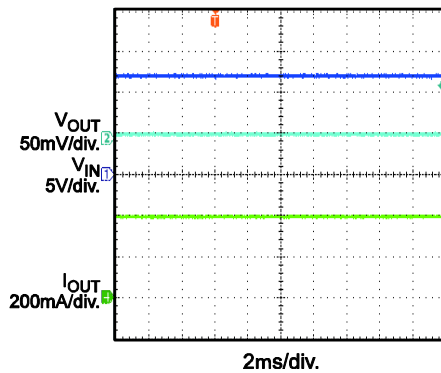

OPERATION

The MPQ2019 is a linear regulator that supplies power to systems with high-voltage batteries. It includes a wide 3V to 40V input range, low-dropout voltage, and a low-quiescent supply current (see Figure 1).

The MPQ2019 provides a wide variety of fixed output-voltage options: 1.8V, 1.9V, 2.3V, 2.5V, 3.0V, 3.3V, 3.45V, and 5.0V; Also, it provides the output-adjustable option (from 1.25V to 15V).

The output-adjustable version has an output that is adjustable from 1.25V to 15V with a simple resistor divider. It uses external feedback, allowing the user to set the output voltage with an external resistor divider. The FB threshold is 1.25V, typically.

The IC enters shutdown mode when EN is low. In shutdown mode, the pass transistor, control circuitry, reference, and all biases turn off; this reduces the supply current to <math><1\mu\text{A}</math>. Connect EN to IN for automatic start-up.

The regulator output current is limited internally, and the device is protected against short-circuit, over-load, and over-temperature conditions (see Figure 2).

The peak-output current is limited to around 1000mA, which exceeds the 300mA recommended continuous-output current.

When the junction temperature is too high, the thermal sensor sends a signal to the control logic

that shuts down the IC. The IC will re-start when the temperature has cooled sufficiently.

The maximum power-output current is a function of the package's maximum power dissipation for a given temperature.

The maximum power dissipation is dependent on the thermal resistance of the case and the circuit board, the temperature difference between the die junction and the ambient air, and the rate of air flow. GND and the exposed pad must be connected to the ground plane for proper dissipation.

MPQ2019 has one power good (PG) pin. The PG pin is the open drain of an internal MOSFET. It should be connected to V_{OUT} or external voltage source (<math><15\text{V}</math>) through a resistor (i.e. 100kohm). After the V_{FB} reaches 93% of nominal value, the MOSFET turns off and PG pin is pulled to high by V_{OUT} or external voltage source. When the V_{FB} drops to 88% of nominal value, the PG voltage is pulled to GND.

There is a delay time when PG asserts high. The delay time can be programmed by adding a capacitor on PGDL. To select a capacitor for PGDL, use below equation:

$$C_{PGDL} \text{ (nF)} = \frac{t_{PGDL} \text{ (ms)} \times I_{PGDL} \text{ (\mu A)}}{V_{th_PGDL} \text{ (V)}}$$

Where t_{PGDL} is the desired delay time for PG asserts high, I_{PGDL} is the PGDL charging current and V_{th_PGDL} is 1.7V.

Figure 2 shows the power good timing.

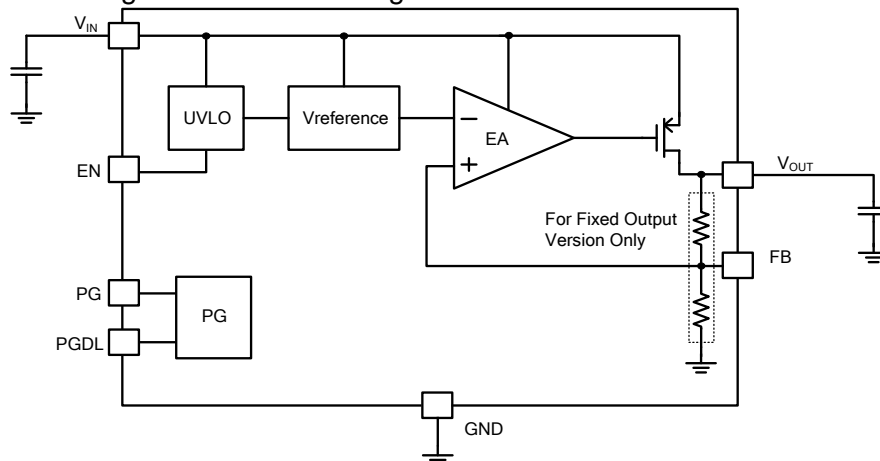

Figure 1. Functional Block Diagram

MPQ2019 - 40V, 300mA, LOW QUIESCENT CURRENT LINEAR REGULATOR

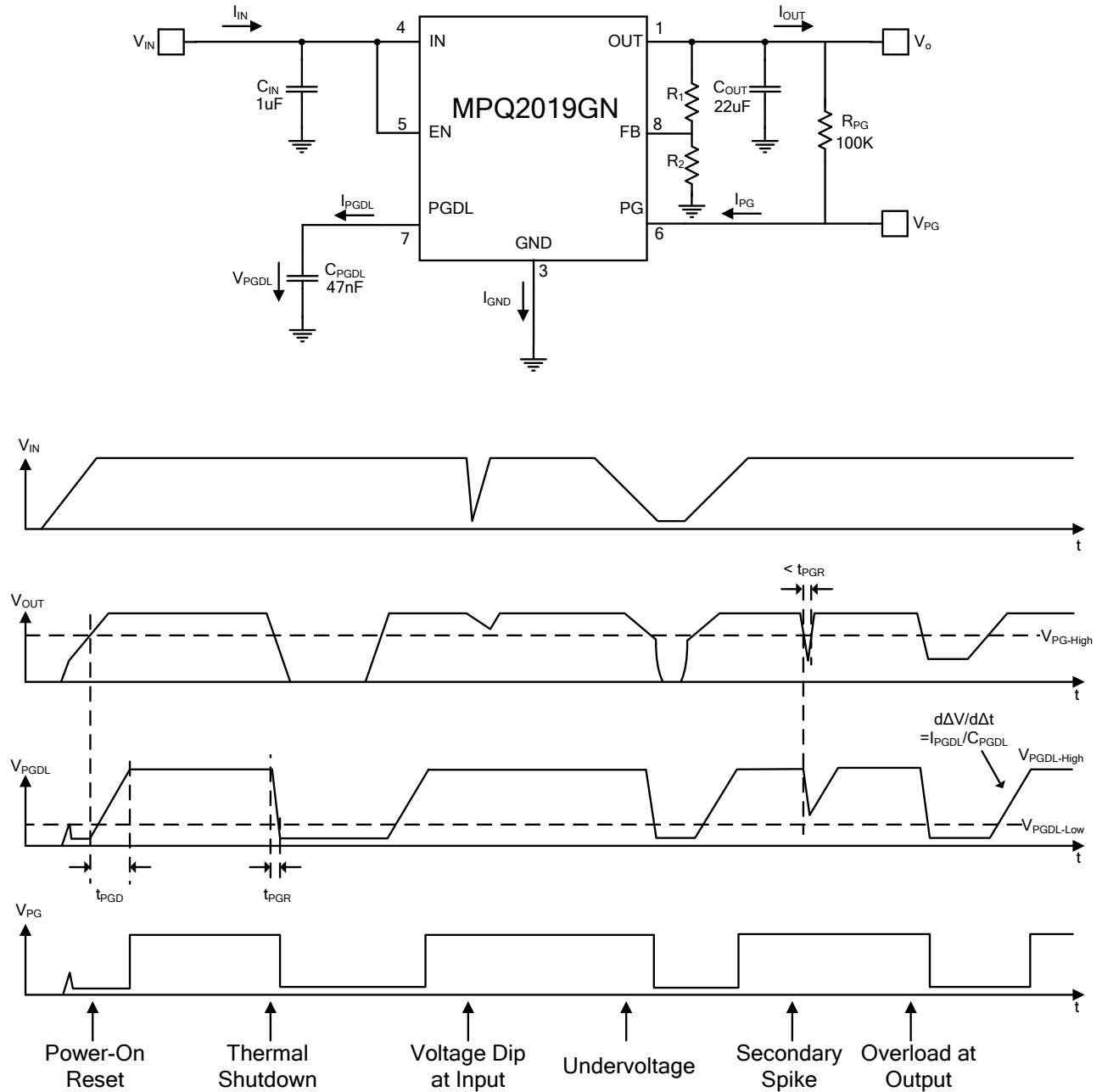

Figure 2. Power Good Timing

APPLICATION INFORMATION

COMPONENT SELECTION

Setting the Output Voltage

Set the output voltage of the MPQ2019 by using a resistor divider (see Figure 3).

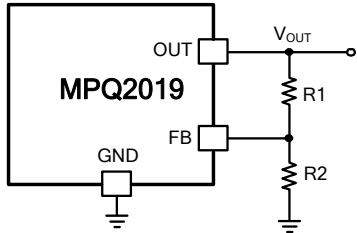

Figure 3. FB Resistor Divider to Set V_{OUT}

Choose R2=1MΩ to maintain a 1.215μA minimum load. Calculate the value for R1 using the following equation:

$$R1 = R2 \times \left(\frac{V_{OUT}}{1.25V} - 1 \right)$$

For a fixed-output version, V_{OUT} can also be adjusted by adding an external resistor divider. When choosing an external divider, just note to take the internal FB resistor divider into consideration.

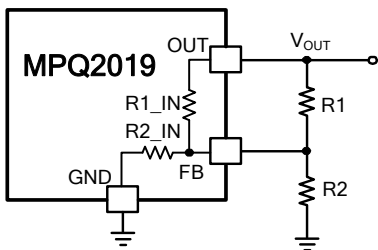

Figure 4. FB Divider for Fixed-Output Version

When R2 is selected, R1 can be calculated by below equation:

$$R1 = \frac{R1_IN}{\frac{1.25 \times R1_IN \times (R2 + R2_IN)}{(V_{OUT} - 1.25) \times R2 \times R2_IN} - 1}$$

The internal FB resistor dividers for different fixed- output versions are shown in below Table.

Table 1. Internal FB Resistor Divider

Fixed-Output Voltage	R1_IN	R2_IN
3.3V	1.64MΩ	1MΩ
5V	3MΩ	1MΩ

Table 2 is an example of external FB divider to get various output voltages on fixed 3.3V output version.

Table 2. 3.3V Fixed Output Version External FB Divider

V _{OUT} (V)	R1 (kΩ)	R2 (kΩ)
11	80.6	10
8.5	59	10
8	54.9	10
6.5	43	10
5	30.1	10

Enable Control (EA)

EN is a digital control pin that turns the regulator on and off. When EN is pulled below 0.3V, the chip shuts down. When EN is pulled above 1.8V, the chip starts up. If this function is not used, EN can be connected to V_{in} directly.

Input Capacitor

For efficient operation, place a ceramic capacitor (C1) between 1μF and 10μF of dielectric type (X5R or X7R) between the input pin and ground. Larger values in this range improve line transient response.

Output Capacitor

For stable operation, use a ceramic capacitor (C2) of type X5R or X7R between 1μF and 22μF. Larger values in this range improve load transient response and reduce noise. Output capacitors of other dielectric types may be used, but they are not recommended as their capacitance can deviate greatly from their rated value over temperature.

To improve load transient response, add a small ceramic (X5R, X7R, or Y5V dielectric) 2.2nF feed-forward capacitor in parallel with R1. The feed-forward capacitor is not required for stable operation.

Output Noise

The MPQ2019 exhibits noise on the output during normal operation. This noise is negligible for most applications. However, in applications that include analog-to-digital converters (ADCs) of more than 12 bits, consider the ADC's power supply rejection specifications. The feed-forward capacitor C2 across R1 reduces significantly the output noise.

External Reverse Voltage Protection

In some situations, e.g. a backup battery is connected as MPQ2019 load, the output voltage may be held up while the input is either pulled to ground, pulled to some intermediate voltage or is floating. Thus, the output voltage is higher than input voltage. Since the MPQ2019 PMOS pass element has a body diode, a current will conduct from the output to input and is not internally limited. It's possible that the IC will be damaged by this unlimited reverse current. To avoid this, it's recommended to place an external diode at input like below.

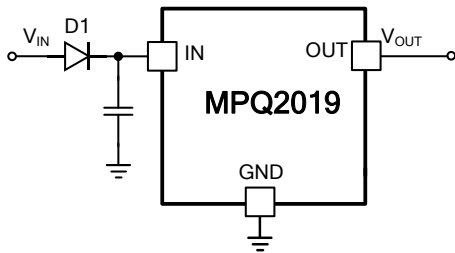

PCB Layout Guidelines

Efficient PCB layout is critical to achieve good regulation, ripple rejection, transient response, and thermal performance. It is recommended highly to duplicate the EVB layout for optimum performance.

If changes are necessary, refer to Figure 5 and follow the guidelines below:

- 1) Place input and output bypass ceramic capacitors close to IN and OUT, respectively.
- 2) Ensure all feedback connections are short and direct. Place the feedback resistors and compensation components as close to the chip as possible.
- 3) Connect IN, OUT, and especially, GND, respectively, to a large copper area to cool the chip. This improves thermal performance and long-term reliability.

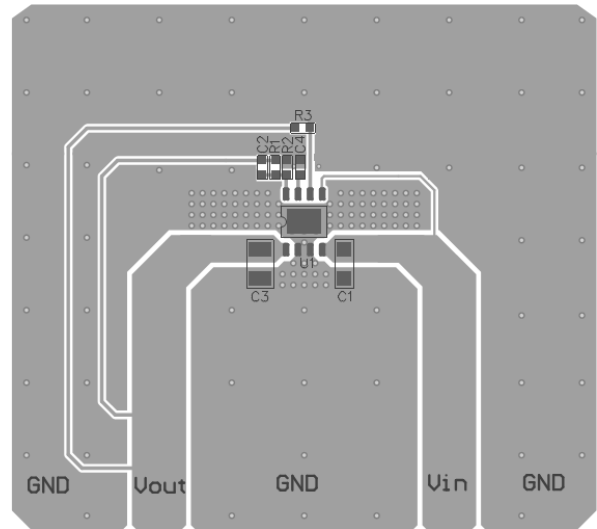
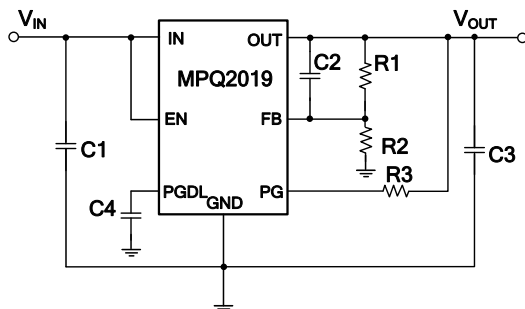

Top Layer

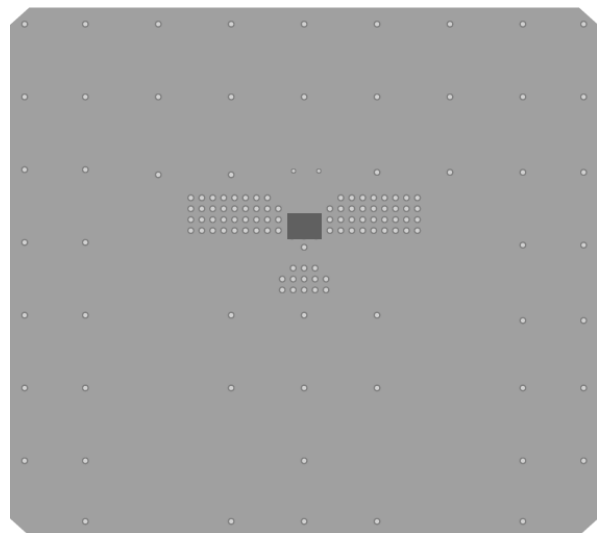

Bottom Layer

Figure 5. Recommended PCB Layout

DESIGN EXAMPLE

Figure 6 is a design example following the application guidelines for $V_{OUT}=3.3V$ with a feed-forward cap:

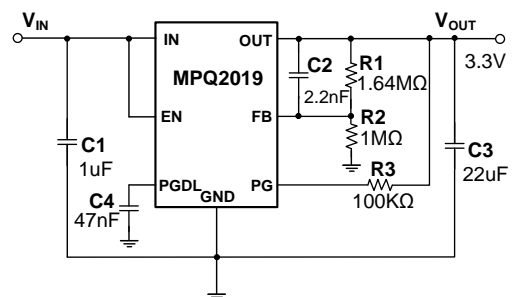

Figure 6. Design Example

TYPICAL APPLICATION CIRCUITS

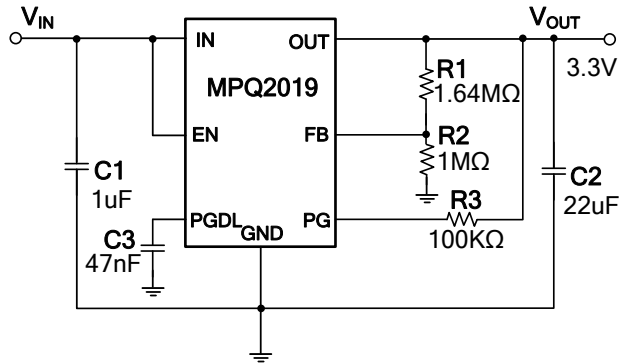

Figure 7. 3.3V Output Typical Application Circuit

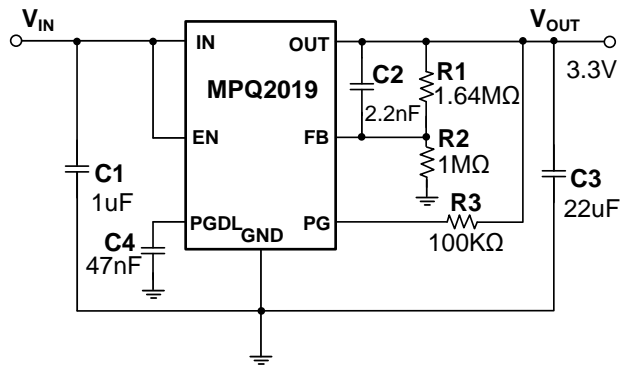
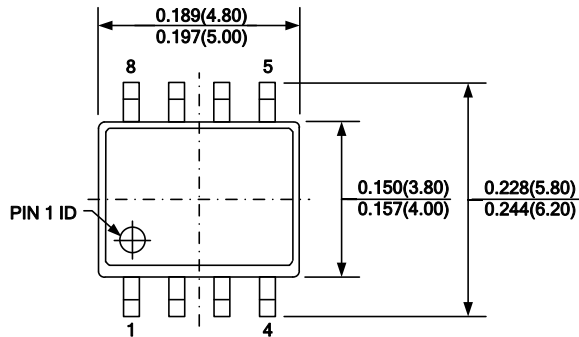

Figure 8. 3.3V Output with Feed-Forward Capacitor

PACKAGE INFORMATION

SOIC-8 EP



TOP VIEW

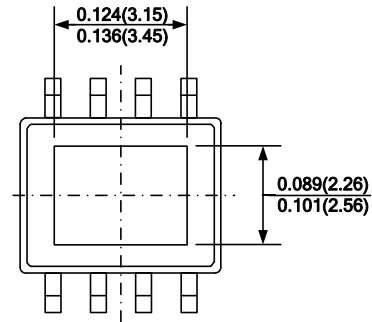

BOTTOM VIEW

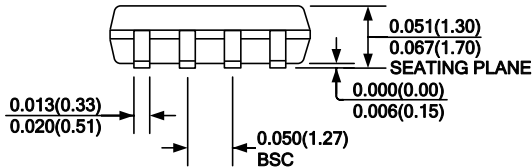

FRONT VIEW

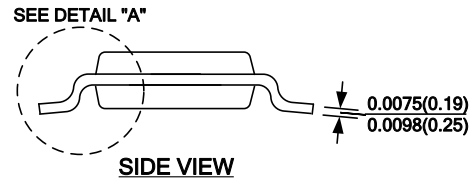

SIDE VIEW

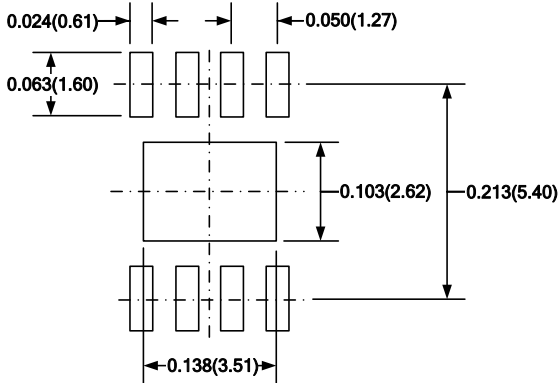

RECOMMENDED LAND PATTERN

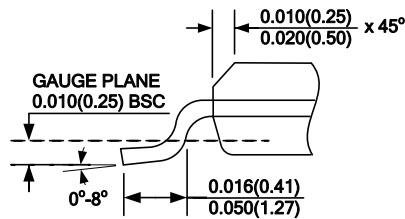

DETAIL "A"

NOTE:

- 1) CONTROL DIMENSION IS IN INCHES. DIMENSION IN BRACKET IS IN MILLIMETERS.
- 2) PACKAGE LENGTH DOES NOT INCLUDE MOLD FLASH, PROTRUSIONS, OR GATE BURRS.
- 3) PACKAGE WIDTH DOES NOT INCLUDE INTERLEAD FLASH OR PROTRUSIONS.
- 4) LEAD COPLANARITY (BOTTOM OF LEADS AFTER FORMING) SHALL BE 0.004" INCHES MAX.
- 5) DRAWING CONFORMS TO JEDEC MS-012, VARIATION BA.
- 6) DRAWING IS NOT TO SCALE.

NOTICE: The information in this document is subject to change without notice. Users should warrant and guarantee that third party Intellectual Property rights are not infringed upon when integrating MPS products into any application. MPS will not assume any legal responsibility for any said applications.