

SGM2217

1.5A, Low Dropout Positive Regulator

GENERAL DESCRIPTION

The SGM2217 is a low dropout linear regulator that operates from 2.8V to 30V and provides output current up to 1.5A. The SGM2217 supplies 1.5A current with a 1.3V typical dropout voltage. Two resistors are required to set the output voltage for the adjustable output voltage version.

The SGM2217 provides high PSRR, low noise and excellent line and load transient responses. Internal protection circuitry includes current limiting and thermal protection.

The SGM2217 is available in fixed output voltage versions and an adjustable output voltage version. The fixed output voltages include 1.8V, 2.5V, 2.8V, 3.0V, 3.3V, 5.0V and 12V.

The SGM2217 is available in Green TO-263-3A and TDFN-4×4-8L packages. It operates over an operating temperature range of -40°C to +125°C.

FEATURES

- **Wide Input Voltage Range: 2.8V to 30V**
- **Adjustable Output Voltage Range: 1.25V to 26V**
- **Fixed Output Voltages: 1.8V, 2.5V, 2.8V, 3.0V, 3.3V, 5.0V and 12V**
- **Maximum Output Current: 1.5A**
- **Low Dropout Voltage: 1.3V (TYP) at 1.5A**
- **Line Regulation: 0.04% (TYP)**
- **Load Regulation: 0.04% (TYP)**
- **Current Limiting and Thermal Protection**
- **Output Voltage is Stable with Ceramic Capacitor**
- **-40°C to +125°C Operating Temperature Range**
- **Available in Green TO-263-3A and TDFN-4×4-8L Packages**

APPLICATIONS

High-Efficiency Linear Regulators
Battery Chargers
Post Regulation for Switching Supplies
Constant Current Regulators
Microprocessor Supplies

TYPICAL APPLICATION

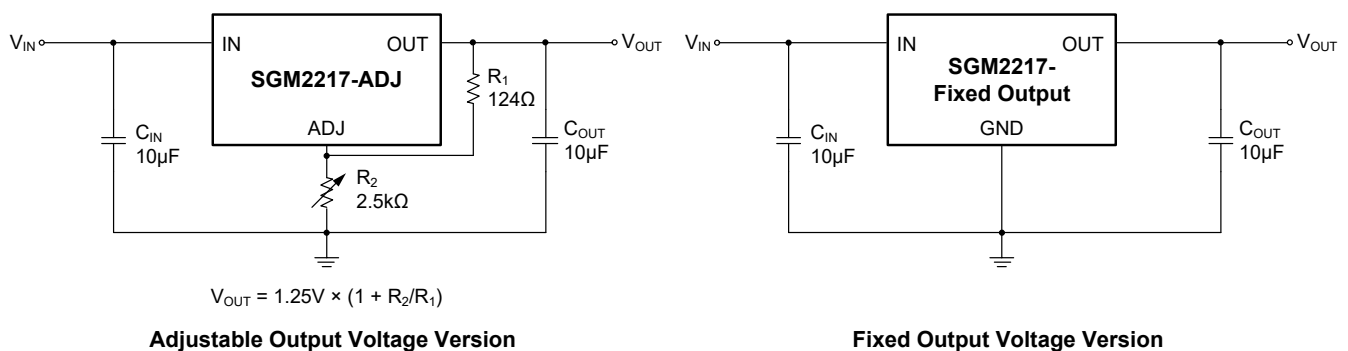

Figure 1. Typical Application Circuits

PACKAGE/ORDERING INFORMATION

MODEL	PACKAGE DESCRIPTION	SPECIFIED TEMPERATURE RANGE	ORDERING NUMBER	PACKAGE MARKING	PACKING OPTION
SGM2217-1.8	TO-263-3A	-40°C to +125°C	SGM2217-1.8XOA3G/TR	SGMR9B XOA3 XXXXXX	Tape and Reel, 800
	TDFN-4x4-8L	-40°C to +125°C	SGM2217-1.8XTEL8G/TR	SGMR9D XTEL8 XXXXXX	Tape and Reel, 3000
SGM2217-2.5	TO-263-3A	-40°C to +125°C	SGM2217-2.5XOA3G/TR	SGMRBA XOA3 XXXXXX	Tape and Reel, 800
	TDFN-4x4-8L	-40°C to +125°C	SGM2217-2.5XTEL8G/TR	SGMRBB XTEL8 XXXXXX	Tape and Reel, 3000
SGM2217-2.8	TO-263-3A	-40°C to +125°C	SGM2217-2.8XOA3G/TR	SGMRBC XOA3 XXXXXX	Tape and Reel, 800
	TDFN-4x4-8L	-40°C to +125°C	SGM2217-2.8XTEL8G/TR	SGMRBD XTEL8 XXXXXX	Tape and Reel, 3000
SGM2217-3.0	TO-263-3A	-40°C to +125°C	SGM2217-3.0XOA3G/TR	SGMRBE XOA3 XXXXXX	Tape and Reel, 800
	TDFN-4x4-8L	-40°C to +125°C	SGM2217-3.0XTEL8G/TR	SGMRBF XTEL8 XXXXXX	Tape and Reel, 3000
SGM2217-3.3	TO-263-3A	-40°C to +125°C	SGM2217-3.3XOA3G/TR	SGMRC0 XOA3 XXXXXX	Tape and Reel, 800
	TDFN-4x4-8L	-40°C to +125°C	SGM2217-3.3XTEL8G/TR	SGMRC1 XTEL8 XXXXXX	Tape and Reel, 3000
SGM2217-5.0	TO-263-3A	-40°C to +125°C	SGM2217-5.0XOA3G/TR	SGMRC2 XOA3 XXXXXX	Tape and Reel, 800
	TDFN-4x4-8L	-40°C to +125°C	SGM2217-5.0XTEL8G/TR	SGMRC3 XTEL8 XXXXXX	Tape and Reel, 3000
SGM2217-12	TO-263-3A	-40°C to +125°C	SGM2217-12XOA3G/TR	SGMR9C XOA3 XXXXXX	Tape and Reel, 800
	TDFN-4x4-8L	-40°C to +125°C	SGM2217-12XTEL8G/TR	SGMRA3 XTEL8 XXXXXX	Tape and Reel, 3000
SGM2217-ADJ	TO-263-3A	-40°C to +125°C	SGM2217-ADJXOA3G/TR	SGM2217 XOA3 XXXXXX	Tape and Reel, 800
	TDFN-4x4-8L	-40°C to +125°C	SGM2217-ADJXTEL8G/TR	SGM2217 XTEL8 XXXXXX	Tape and Reel, 3000

MARKING INFORMATION

NOTE: XXXXX = Date Code, Trace Code and Vendor Code.

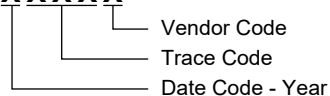
XXXXX

Green (RoHS & HSF): SG Micro Corp defines "Green" to mean Pb-Free (RoHS compatible) and free of halogen substances. If you have additional comments or questions, please contact your SGMICRO representative directly.

ABSOLUTE MAXIMUM RATINGS

Input to Output Voltage	31V
Package Thermal Resistance	
TO-263-3A, θ_{JA}	30°C/W
TO-263-3A, θ_{JB}	32°C/W
TO-263-3A, $\theta_{JC(TOP)}$	5°C/W
TO-263-3A, $\theta_{JC(BOT)}$	2°C/W
TDFN-4×4-8L, θ_{JA}	42°C/W
TDFN-4×4-8L, θ_{JB}	16°C/W
TDFN-4×4-8L, $\theta_{JC(TOP)}$	27°C/W
TDFN-4×4-8L, $\theta_{JC(BOT)}$	2°C/W
Junction Temperature	+150°C
Storage Temperature Range	-65°C to +150°C
Lead Temperature (Soldering, 10s)	+260°C
ESD Susceptibility	
HBM	3000V
CDM	1000V

RECOMMENDED OPERATING CONDITIONS

Input Voltage Range	2.8V to 30V
Input Capacitance, C_{IN}	2.3 μ F (MIN)
Output Capacitance, C_{OUT}	2.3 μ F to 100 μ F
Capacitor Effective Series Resistance, ESR	1m Ω to 8 Ω
Operating Junction Temperature Range	-40°C to +125°C

OVERSTRESS CAUTION

Stresses beyond those listed in Absolute Maximum Ratings may cause permanent damage to the device. Exposure to absolute maximum rating conditions for extended periods may affect reliability. Functional operation of the device at any conditions beyond those indicated in the Recommended Operating Conditions section is not implied.

ESD SENSITIVITY CAUTION

This integrated circuit can be damaged if ESD protections are not considered carefully. SGMICRO recommends that all integrated circuits be handled with appropriate precautions. Failure to observe proper handling and installation procedures can cause damage. ESD damage can range from subtle performance degradation to complete device failure. Precision integrated circuits may be more susceptible to damage because even small parametric changes could cause the device not to meet the published specifications.

DISCLAIMER

SG Micro Corp reserves the right to make any change in circuit design, or specifications without prior notice.

PIN CONFIGURATIONS

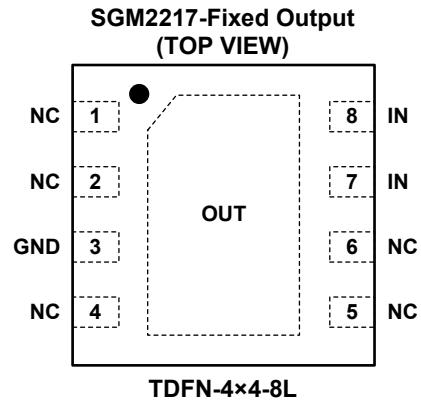
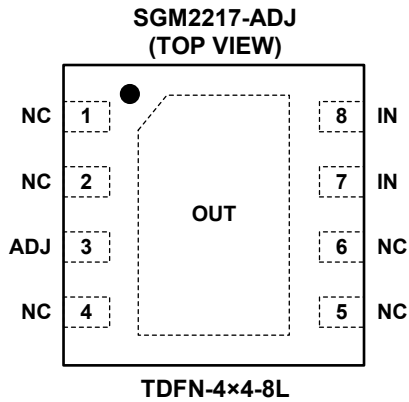
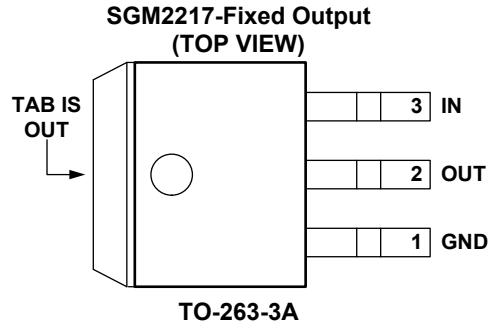
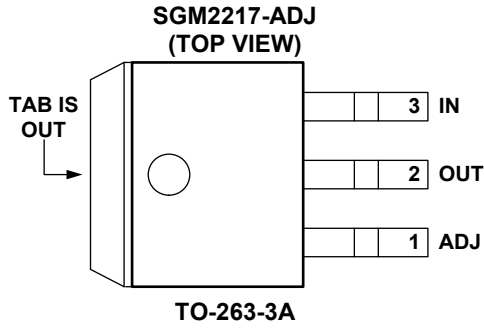

PIN DESCRIPTION

PIN		NAME	FUNCTION
TO-263-3A	TDFN-4x4-8L		
1	3	ADJ	Adjustable Input (adjustable output voltage version only). An external resistor divider sets the output voltage.
		GND	Ground (fixed output voltage version only).
2, TAB	Exposed Pad	OUT	Regulated Output Voltage. It is recommended to use output capacitor with effective capacitance in the range of 2.3μF to 100μF with an ESR of 8Ω or less.
3	7, 8	IN	Regulator Input Supply. Bypass IN pin to GND with a 4.7μF or larger capacitor. The capacitor should be located very close to this pin. Additional capacitance may be required to provide a stable input voltage.
—	1, 2, 4, 5, 6	NC	No Connection.

ELECTRICAL CHARACTERISTICS

(T_J = -40°C to +125°C, typical values are at T_J = +25°C, C_{IN} = C_{OUT} = 10μF (ceramic capacitor), unless otherwise noted.)

PARAMETER	SYMBOL	CONDITIONS	MIN	TYP	MAX	UNITS
Reference Voltage (SGM2217-ADJ)	V _{REF}	I _{OUT} = 5mA, (V _{IN} - V _{OUT}) = 3V, T _J = +25°C	1.238	1.25	1.262	V
		I _{OUT} = 5mA to 1.5A ⁽¹⁾ , V _{IN} = (1.55V + V _{OUT}) to 30V	1.225		1.275	
Output Voltage Accuracy (SGM2217-Fixed Output)	V _{OUT}	I _{OUT} = 0mA, (V _{IN} - V _{OUT}) = 3V, T _J = +25°C	-1		+1	%
		I _{OUT} = 0mA to 1.5A ⁽¹⁾ , V _{IN} = (1.55V + V _{OUT}) to 30V	-2		+2	
Line Regulation	$\frac{\Delta V_{OUT}}{V_{OUT}}$	I _{OUT} = 5mA, V _{IN} = (1.55V + V _{OUT}) to 30V, SGM2217-ADJ, T _J = +25°C		0.04	0.16	%
		I _{OUT} = 5mA, V _{IN} = (1.55V + V _{OUT}) to 30V, SGM2217-ADJ			0.20	
		I _{OUT} = 0mA, V _{IN} = (1.55V + V _{OUT}) to 30V, SGM2217-Fixed Output, T _J = +25°C		0.04	0.16	
		I _{OUT} = 0mA, V _{IN} = (1.55V + V _{OUT}) to 30V, SGM2217-Fixed Output			0.20	
Load Regulation	$\frac{\Delta V_{OUT}}{V_{OUT}}$	I _{OUT} = 5mA to 1.5A, (V _{IN} - V _{OUT}) = 3V, T _J = +25°C		0.04	0.3	%
		I _{OUT} = 5mA to 1.5A, (V _{IN} - V _{OUT}) = 3V			0.4	
		I _{OUT} = 0mA to 1.5A, (V _{IN} - V _{OUT}) = 3V, T _J = +25°C		0.04	0.3	
		I _{OUT} = 0mA to 1.5A, (V _{IN} - V _{OUT}) = 3V			0.4	
Dropout Voltage	V _{DROP}	I _{OUT} = 1.5A, ΔV _{OUT} = 1%		1.3	1.55	V
Output Current Limit	I _{LIMIT}	(V _{IN} - V _{OUT}) = 5V, ΔV _{OUT} = 5%	1.55	3		A
		(V _{IN} - V _{OUT}) = 25V, V _{OUT} = 0V	0.05	0.3		
Thermal Regulation		30ms Pulse, T _J = +25°C		0.01	0.07	%/W
Supply Pin Current	I _Q	V _{IN} = 30V, I _{OUT} = 0mA, SGM2217-Fixed Output		2	5	mA
Minimum Load Current ⁽¹⁾	I _{OUT_MIN}	V _{IN} = 30V, SGM2217-ADJ		2	5	mA
ADJ Pin Current	I _{ADJ}	I _{OUT} = 5mA, (V _{IN} - V _{OUT}) = 3V, SGM2217-ADJ		8	20	μA
ADJ Pin Current Change	ΔI _{ADJ}	I _{OUT} = 5mA to 1.5A ⁽²⁾ , (V _{IN} - V _{OUT}) = 1.55V to 15V, SGM2217-ADJ		0.2	2	μA
Turn-On Time	t _{ON}	From assertion of V _{IN} to V _{OUT} = 95% × V _{OUT(NOM)}		0.2	1	ms
Temperature Stability				0.5		%
Long Term Stability		1000 hours, T _J = +125°C		0.3		%
Power Supply Ripple Rejection	PSRR	ΔV _{RIPPLE} = 3V _{P-P} , (V _{IN} - V _{OUT}) = 3V, I _{OUT} = 1.5A, f _{RIPPLE} = 120Hz, C _{OUT} = 20μF	C _{ADJ} = 25μF, SGM2217-ADJ		72	dB
			V _{OUT} = 1.8V		68	
			V _{OUT} = 3.3V		64	
			V _{OUT} = 5.0V		60	
			V _{OUT} = 12V		53	
Output Voltage Noise	e _n	f = 10Hz to 10kHz, I _{OUT} = 1.5A		0.004		%
Thermal Shutdown Temperature	T _{SHDN}			160		°C
Thermal Shutdown Hysteresis	ΔT _{SHDN}			20		°C

NOTES:

- The minimum output current required to maintain regulation.
- Output current limit is a function of input-to-output voltage. See short-circuit current curve for available output current at the input-to-output differential.

TYPICAL PERFORMANCE CHARACTERISTICS

$T_J = +25^\circ\text{C}$, $(V_{IN} - V_{OUT}) = 3\text{V}$, $C_{IN} = C_{OUT} = 10\mu\text{F}$ (ceramic capacitor), unless otherwise noted.

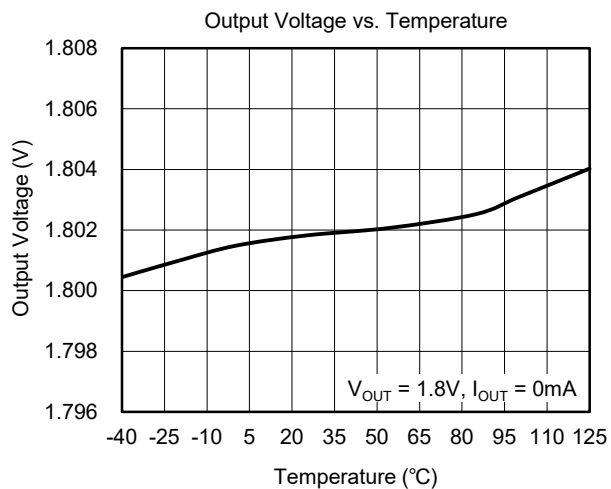
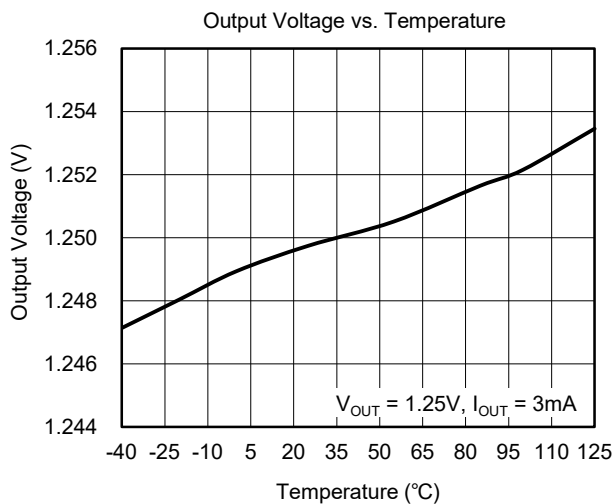
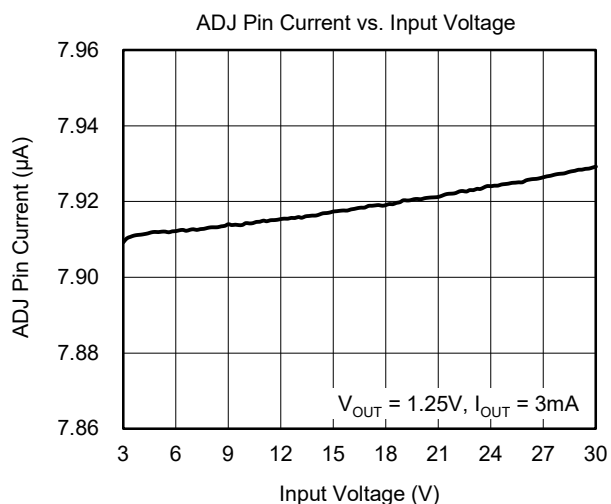
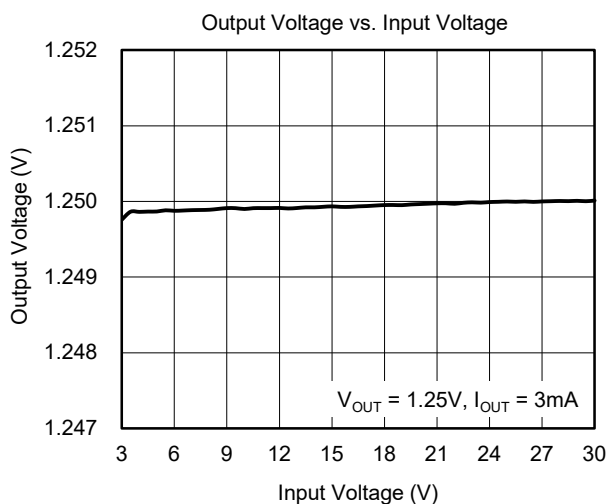
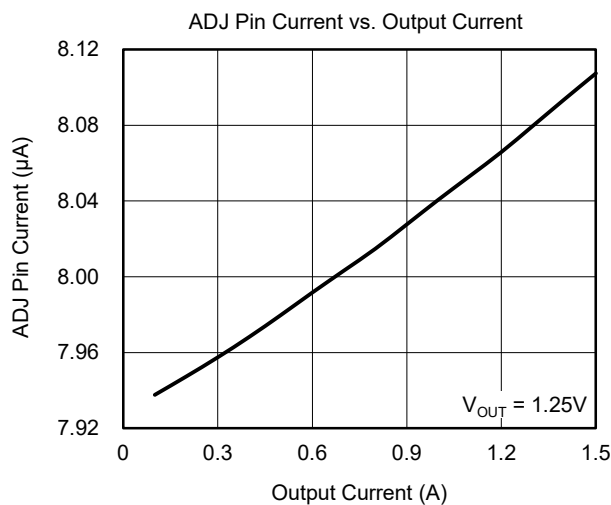
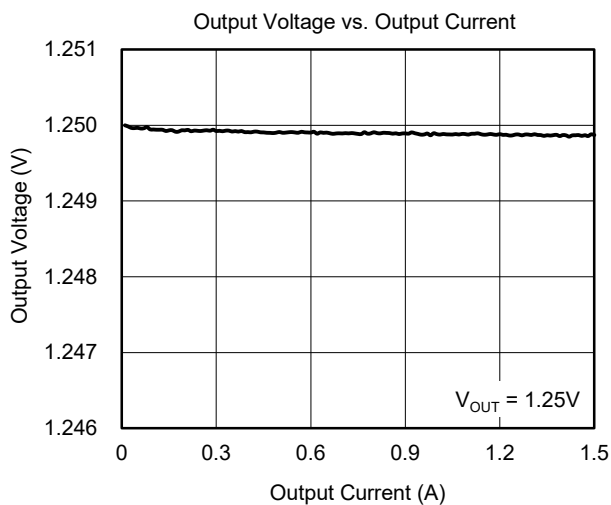

TYPICAL PERFORMANCE CHARACTERISTICS (continued)

$T_J = +25^\circ\text{C}$, $(V_{IN} - V_{OUT}) = 3\text{V}$, $C_{IN} = C_{OUT} = 10\mu\text{F}$ (ceramic capacitor), unless otherwise noted.

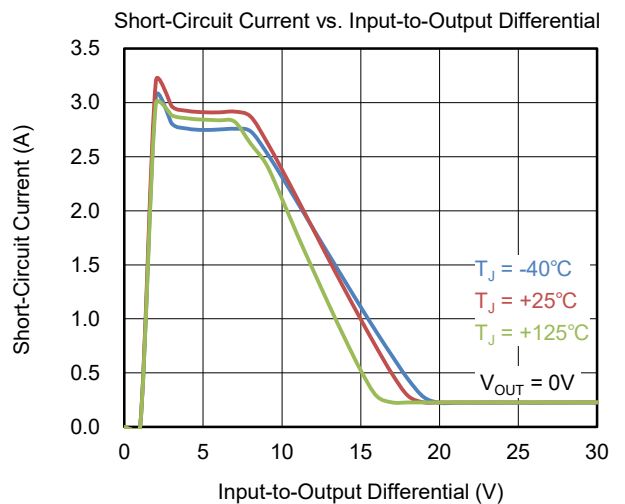
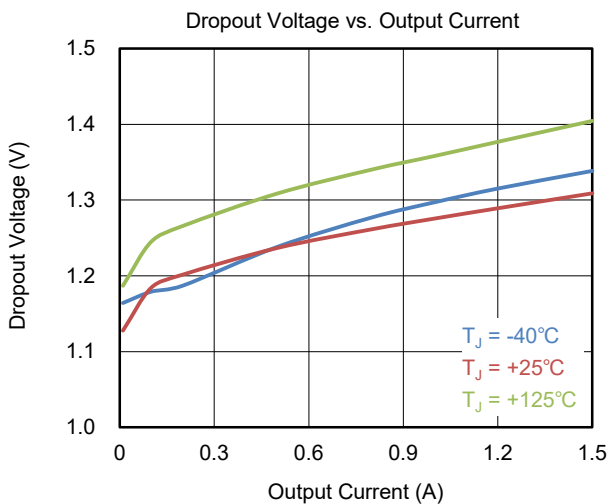
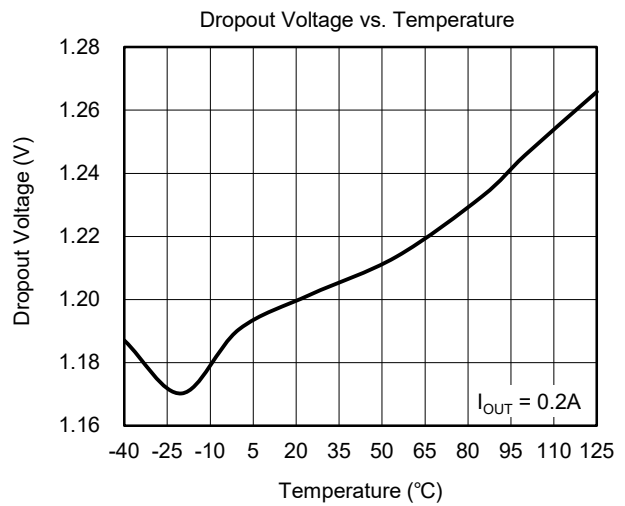
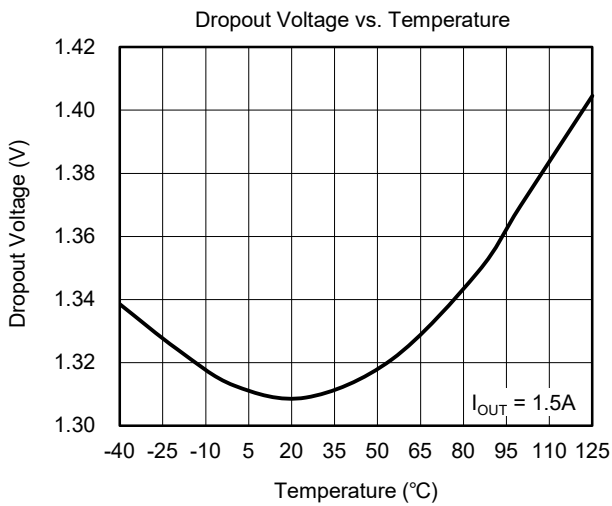
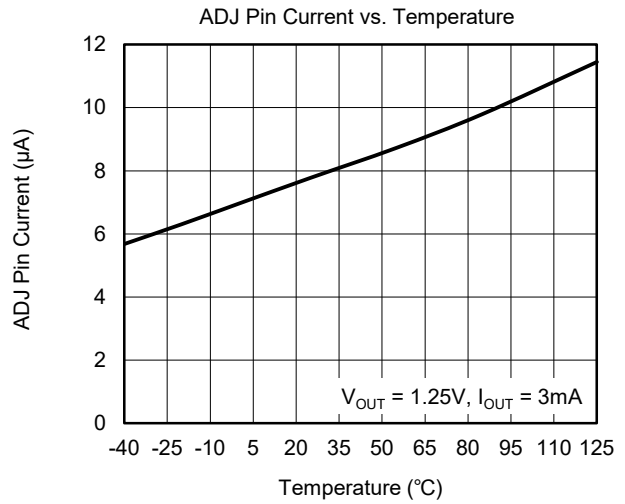
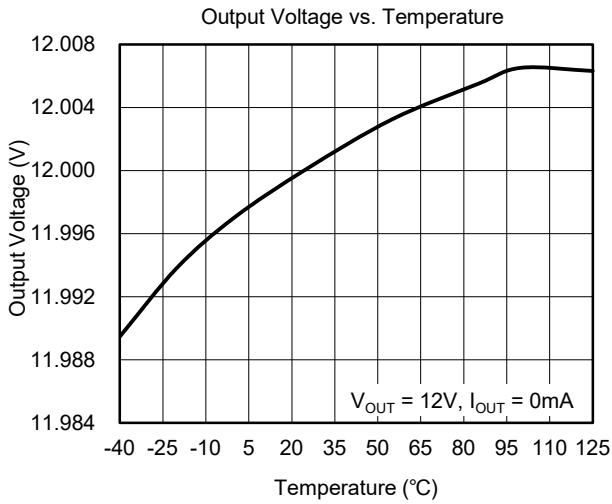

TYPICAL PERFORMANCE CHARACTERISTICS (continued)

$T_J = +25^\circ\text{C}$, $(V_{IN} - V_{OUT}) = 3\text{V}$, $C_{IN} = C_{OUT} = 10\mu\text{F}$ (ceramic capacitor), unless otherwise noted.

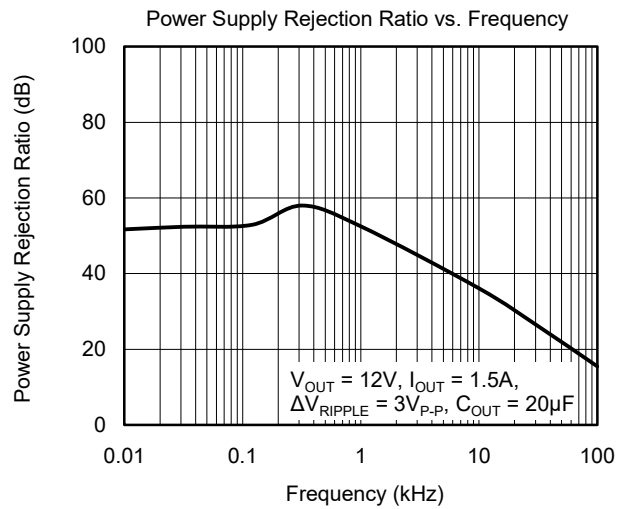
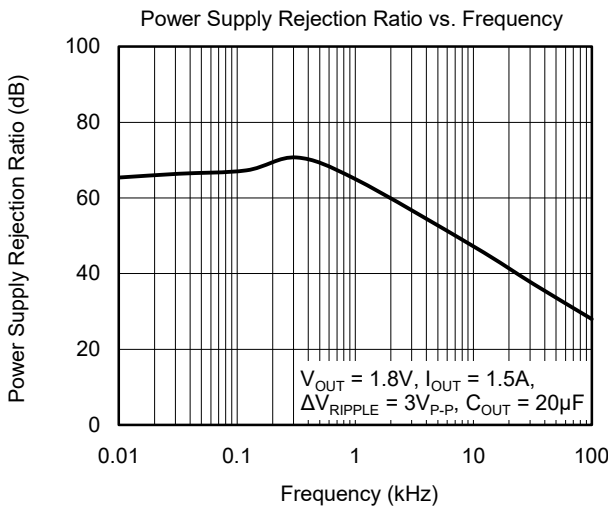
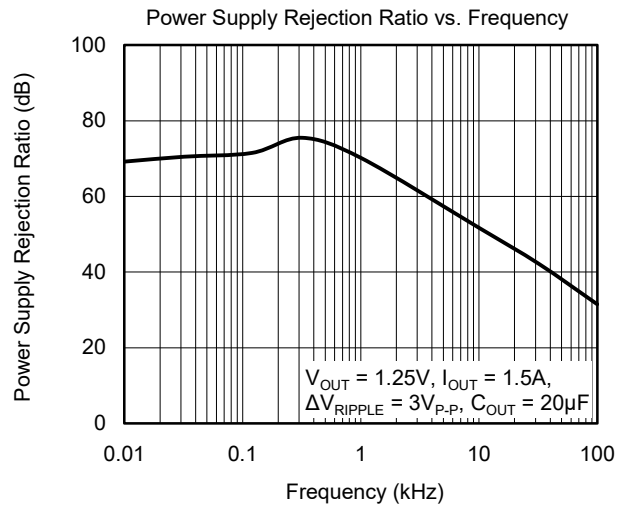
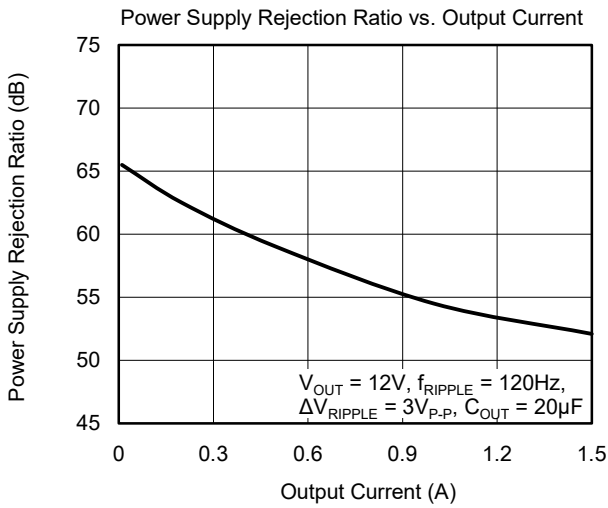
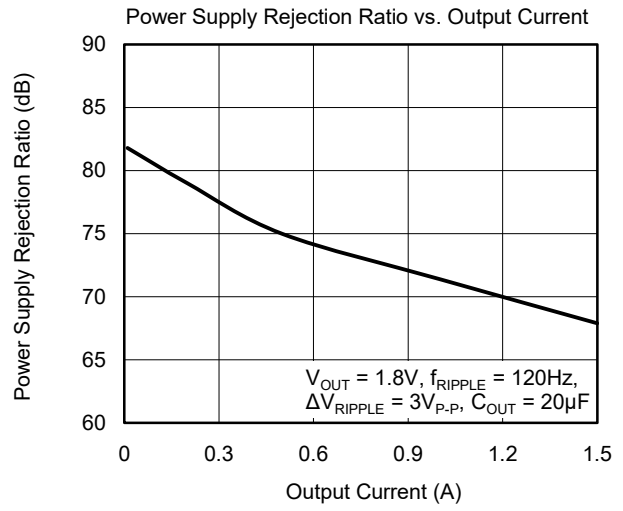
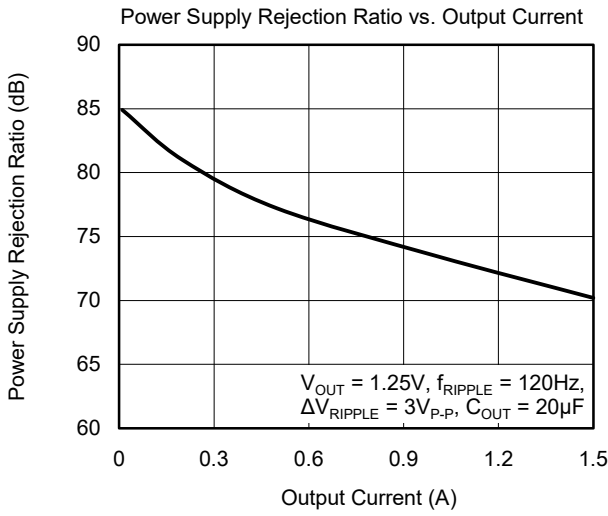

TYPICAL PERFORMANCE CHARACTERISTICS (continued)

$T_J = +25^\circ\text{C}$, $(V_{IN} - V_{OUT}) = 3\text{V}$, $C_{IN} = C_{OUT} = 10\mu\text{F}$ (ceramic capacitor), unless otherwise noted.

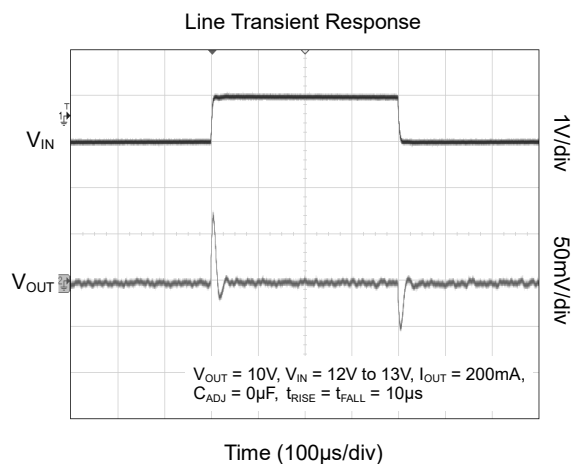
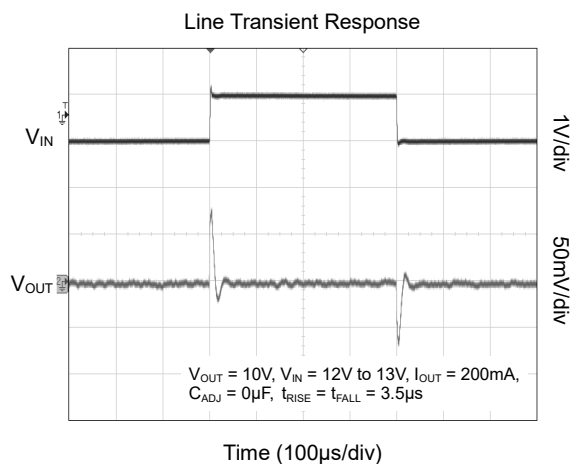
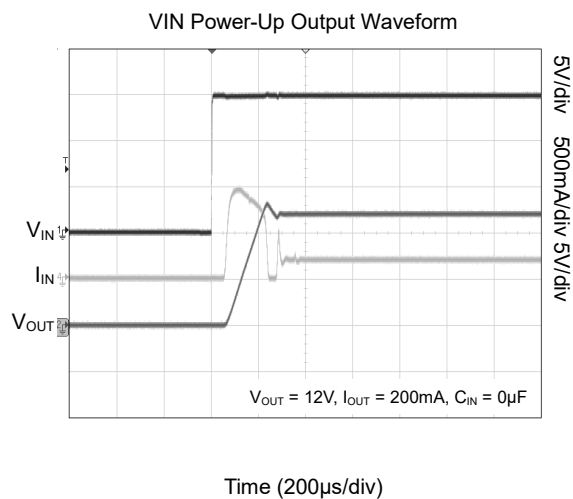
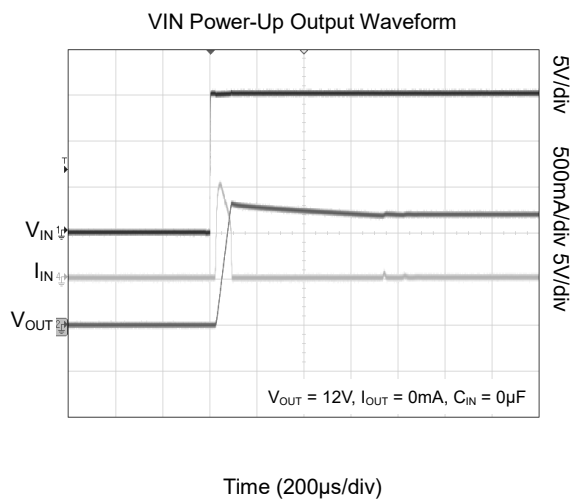
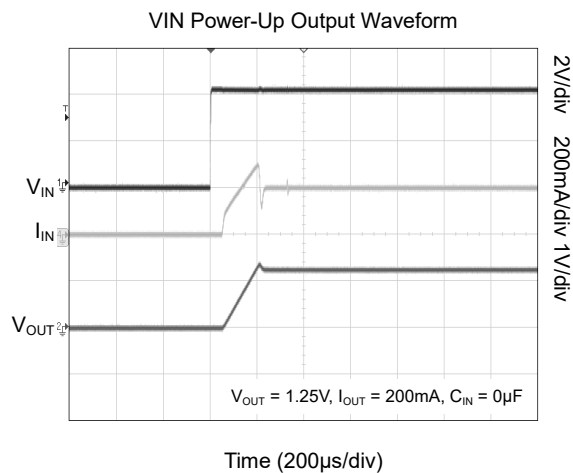
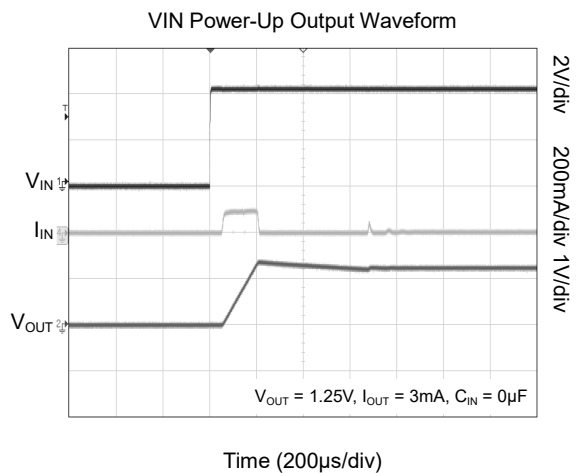

TYPICAL PERFORMANCE CHARACTERISTICS (continued)

$T_J = +25^\circ\text{C}$, $(V_{IN} - V_{OUT}) = 3\text{V}$, $C_{IN} = C_{OUT} = 10\mu\text{F}$ (ceramic capacitor), unless otherwise noted.

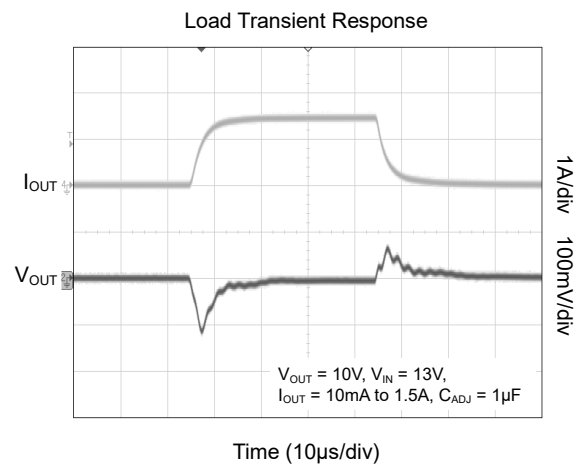
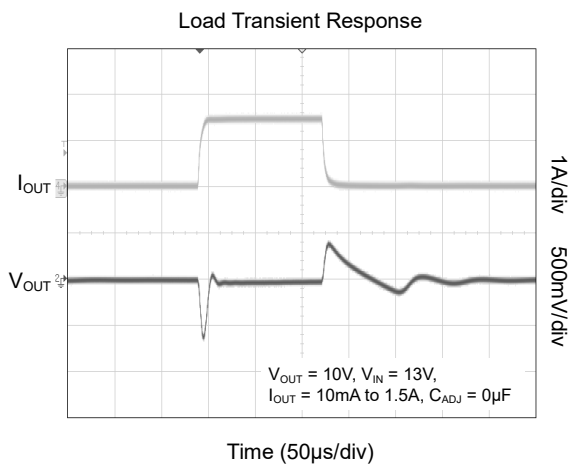
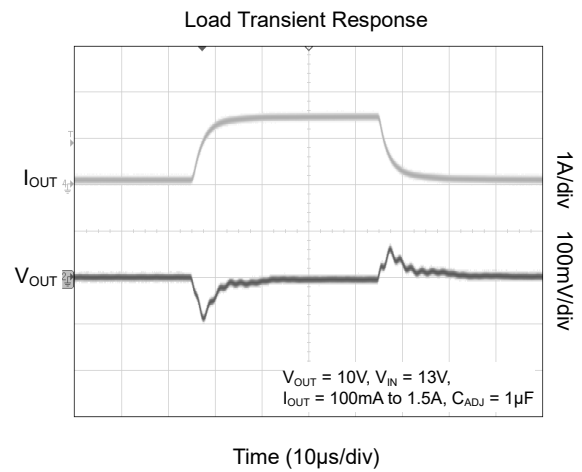
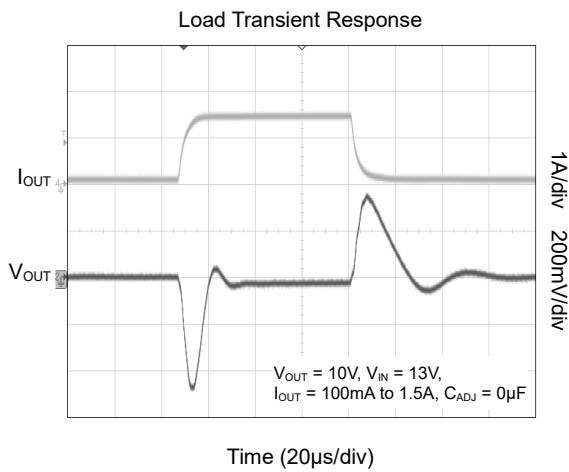
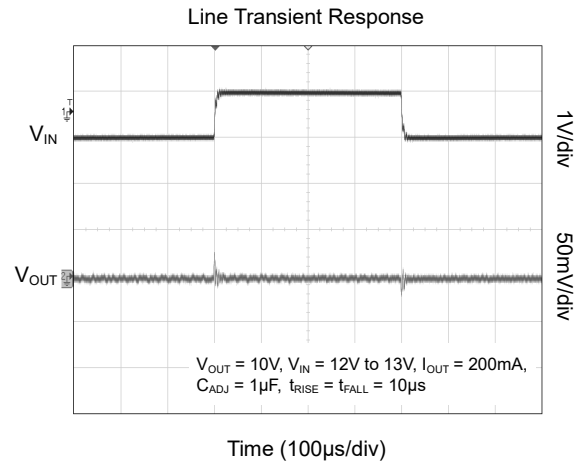
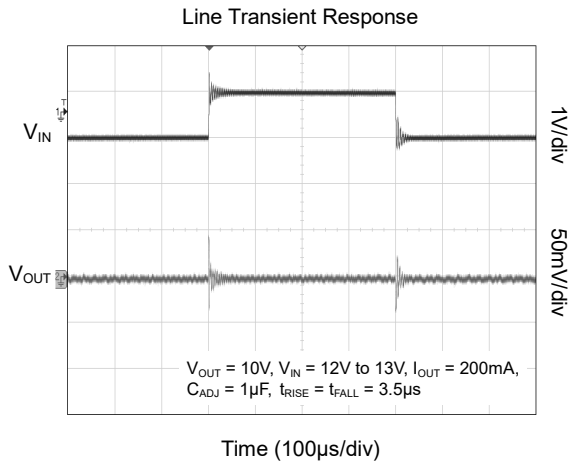

TYPICAL PERFORMANCE CHARACTERISTICS (continued)

$T_J = +25^\circ\text{C}$, $(V_{IN} - V_{OUT}) = 3\text{V}$, $C_{IN} = C_{OUT} = 10\mu\text{F}$ (ceramic capacitor), unless otherwise noted.

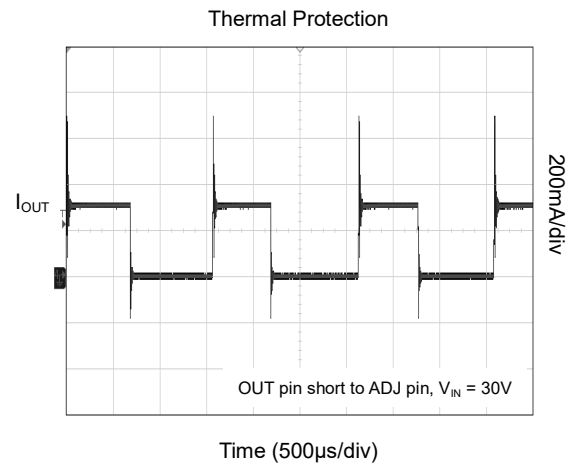
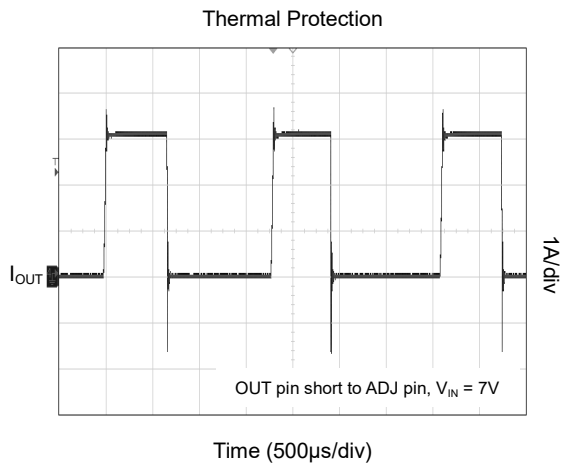

FUNCTIONAL BLOCK DIAGRAM

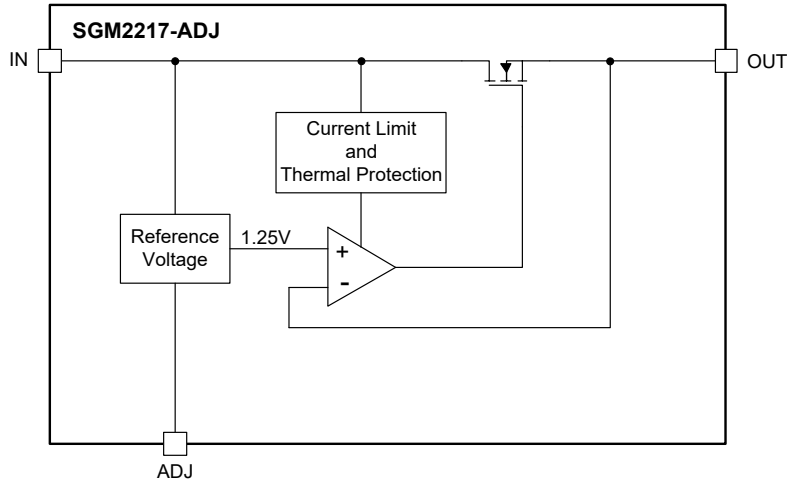

Figure 2. Adjustable Output Voltage Internal Block Diagram

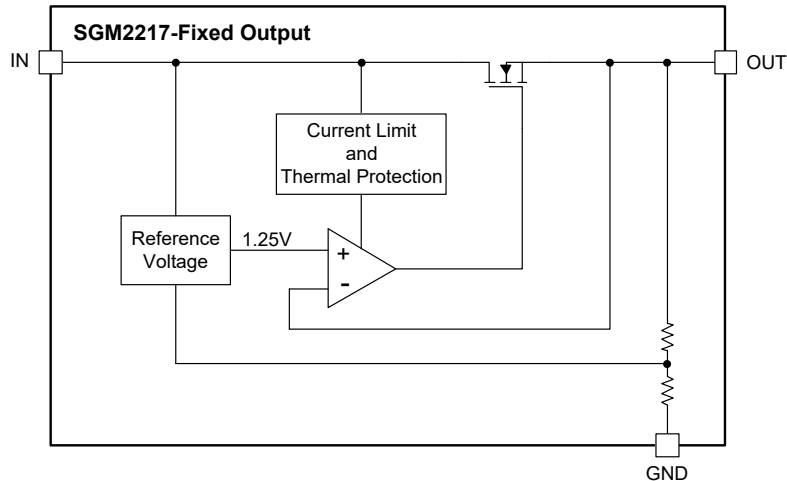

Figure 3. Fixed Output Voltage Internal Block Diagram

DETAILED DESCRIPTION

A basic functional diagram for the SGM2217-ADJ is shown in Figure 2. Internally, the SGM2217-ADJ consists of a voltage reference, an error amplifier and an NMOS pass transistor. Output current is delivered via the NMOS pass device, which is controlled by the error amplifier.

Overload Recovery

Overload recovery refers to regulator's ability to recover from a short circuited output. A key factor in the recovery process is the current limiting used to protect the output from drawing too much power. The current limiting

circuit reduces the output current as the input-to-output differential increases after 2ms of power-on.

During normal start-up, the input-to-output differential is small since the output follows the input. But, if the output is shorted, then the recovery involves a large input-to-output differential. Sometimes during this condition the current limiting circuit is slow in recovering. If the limited current is too low to develop a voltage at the output, the voltage will stabilize at a lower level. Under these conditions it may be necessary to recycle the power of the regulator in order to get the smaller differential voltage and thus adequate start-up conditions.

APPLICATION INFORMATION

Output Voltage

The SGM2217-ADJ develops a 1.25V reference voltage (V_{REF}) between the output and the adjustment terminal. As shown in Figure 4, this voltage is applied across resistor R_1 to generate a constant current I_1 . This constant current then flows through R_2 . The resulting voltage drop across R_2 adds to the reference voltage to set the desired output voltage.

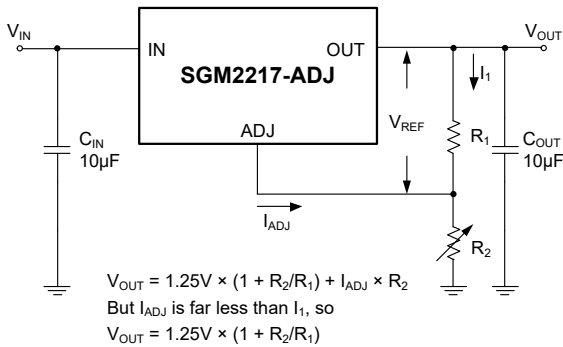

Figure 4. Basic Adjustable Regulator

Power Supply Rejection Ratio and Noise

Power Supply Rejection Ratio is a function of the open-loop gain within the feedback loop (refer to Figure 2 and Figure 4). The SGM2217-ADJ exhibits 72dB (TYP) of ripple rejection. When adjusted voltages higher than V_{REF} , the ripple rejection decreases as a function of adjustment gain: $(1 + R_2/R_1)$ or V_{OUT}/V_{REF} . Therefore, a 5V adjustment decreases ripple rejection by a factor of four (-12dB). Output ripple increases as adjustment voltage increases.

The ultra-low output noise is achieved by keeping the LDO error amplifier in unity gain and setting the reference voltage equal to the output voltage. The adjustable output uses the more conventional architecture where the reference voltage is fixed, and the error amplifier gain is a function of the output voltage. The disadvantage of the conventional LDO architecture is that the output voltage noise is proportional to the output voltage.

However, the PSRR and noise of adjustable LDO circuit can be modified slightly to levels close to that of the unity-gain LDO. The adjustment terminal can be bypassed to ground with a capacitor (C_{ADJ}). The impedance of the C_{ADJ} should be equal to or less than R_2 at the desired frequency.

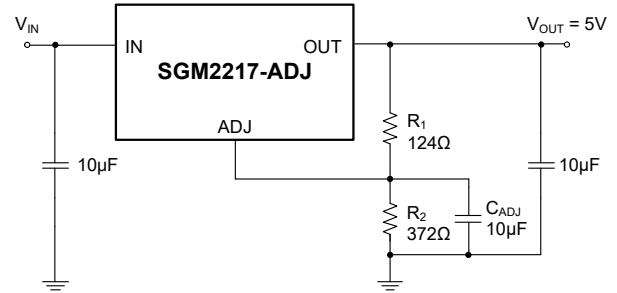

Figure 5. PSRR Enhancement and Noise Reduction Modification

Output Capacitor Selection

The SGM2217 is designed to operate with small size ceramic capacitors; moreover, other types of capacitors also can be used. The ESR of capacitor is the most important parameter to be taken into account, and the ESR of the output capacitor affects the stability of the LDO. A capacitor with effective capacitance in the range of 2.3µF to 100µF with an ESR of 8Ω or less is recommended to ensure the stability of the SGM2217. If good load transient response is important in application, larger output capacitor and lower ESR can be used.

Power Supply Recommendations

The linear regulator input supply should be well regulated and kept at a voltage level such that the maximum input-to-output voltage differential allowed by the device is not exceeded. The minimum dropout voltage ($V_{IN} - V_{OUT}$) should be met with extra headroom when possible in order to keep the output well regulated. A 10µF or higher capacitor should be placed at the input to bypass noise.

Layout Guidelines

For the best overall performance, some layout guidelines should be followed. Place all circuit components on the same side of the circuit board and as close as practical to the respective linear regulator pins connections. Traces should be kept short and wide to reduce the amount of parasitic elements into the system. The actual width and thickness of traces will depend on the current carrying capability and heat dissipation required by the end system. An array of plated vias can be placed on the pad area underneath the TAB to conduct heat to any inner plane areas or to a bottom-side copper plane.

PACKAGE INFORMATION

PACKAGE OUTLINE DIMENSIONS

TO-263-3A

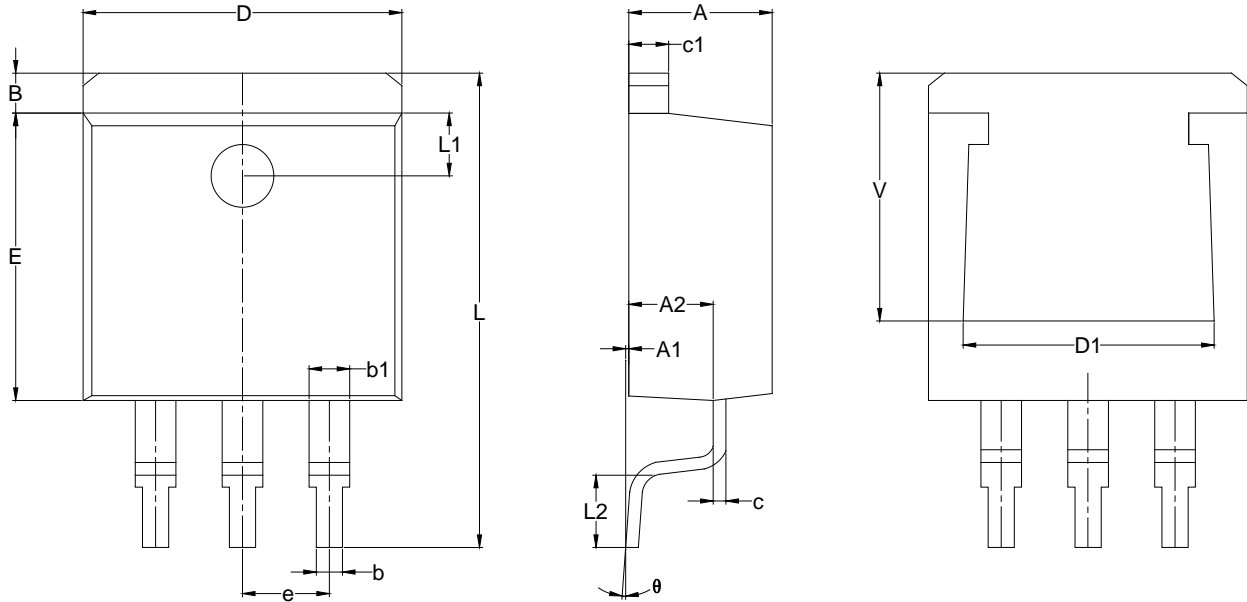

Symbol	Dimensions In Millimeters		
	MIN	MOD	MAX
A	4.400	4.570	4.700
A1	0.000	0.100	0.250
A2	2.590	2.690	2.790
B	1.170	1.270	1.400
b	0.770	-	0.900
b1	1.230	-	1.360
c	0.340	-	0.470
c1	1.220	-	1.320
D	10.060	10.160	10.260
D1	7.800	-	8.200
E	9.050	9.150	9.250
e	2.540 BSC		
L	14.700	15.100	15.500
L1	2.000 REF		
L2	2.000	2.300	2.600
V	6.600	-	-
θ	0°		8°

NOTE: This drawing is subject to change without notice.

PACKAGE INFORMATION

PACKAGE OUTLINE DIMENSIONS

TDFN-4x4-8L

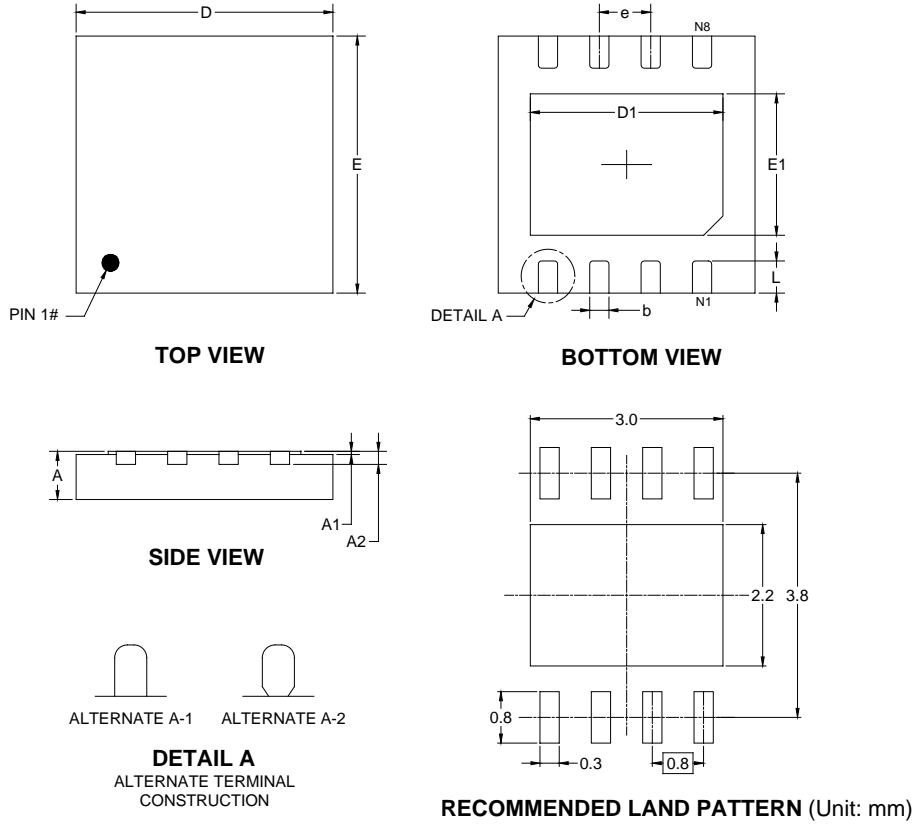

Symbol	Dimensions In Millimeters		
	MIN	MOD	MAX
A	0.700	0.750	0.800
A1	-	-	0.050
A2	0.203 REF		
D	3.950	4.000	4.050
D1	2.950	3.000	3.050
E	3.950	4.000	4.050
E1	2.150	2.200	2.250
b	0.250	0.300	0.350
e	0.800 BSC		
L	0.450	0.500	0.550

NOTE: This drawing is subject to change without notice.

PACKAGE INFORMATION

TAPE AND REEL INFORMATION

REEL DIMENSIONS

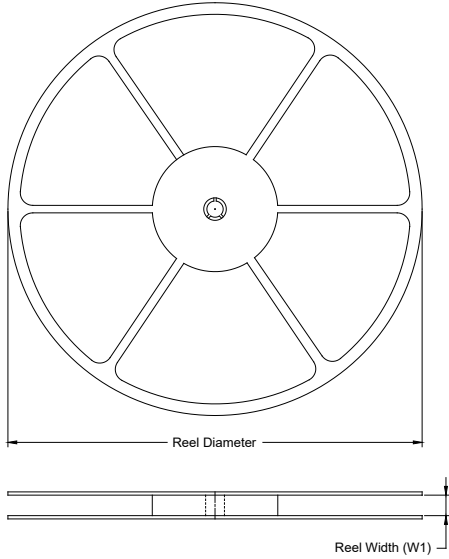

TAPE DIMENSIONS



NOTE: The picture is only for reference. Please make the object as the standard.

KEY PARAMETER LIST OF TAPE AND REEL

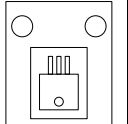
Package Type	Reel Diameter	Reel Width W1 (mm)	A0 (mm)	B0 (mm)	K0 (mm)	P0 (mm)	P1 (mm)	P2 (mm)	W (mm)	Pin1 Quadrant
TO-263-3A	13"	24.4	10.80	16.30	5.11	4.0	16.0	2.0	24.0	
TDFN-4x4-8L	13"	12.4	4.30	4.30	1.10	4.0	8.0	2.0	12.0	Q2

DD0001

PACKAGE INFORMATION

CARTON BOX DIMENSIONS



NOTE: The picture is only for reference. Please make the object as the standard.

KEY PARAMETER LIST OF CARTON BOX

Reel Type	Length (mm)	Width (mm)	Height (mm)	Pizza/Carton
13"	386	280	370	5

DD0002