

TMI8420/Q Dual-Bridge Motor Controller IC

FEATURES

- 8V to 45-V Operating Supply Voltage Range
- PWM Microstepping Stepper Motor Driver
 - Built-In Microstepping Indexer
 - Up to 1/32 Microstepping
- Multiple Decay Modes
 - Mixed Decay
 - Slow Decay
 - Fast Decay
- 2.5-A Maximum Drive Current at 24 V and TA=25°C
- Simple STEP/DIR Interface
- Low Current Sleep Mode
- Built In 3.3-V Reference Output
- Protection Features
 - Overcurrent Protection (OCP)
 - Thermal Shutdown (TSD)
 - VM Undervoltage Lockout (UVLO)
 - Fault Condition Indication Pin (nFAULT)
- Small Packages
 - TMI8420: HTSSOP28
 - TMI8420Q: QFN5*5-28

APPLICATIONS

- Automatic Teller Machines
- Money Handling Machines
- Video Security Cameras
- Printers
- Scanners
- Office Automation Machines
- Gaming Machines
- Factory Automation
- Robotics

GENERAL DESCRIPTION

The TMI8420/Q provides an integrated motor driver solution for printers, scanners, and other automated equipment applications. The device has two H-bridge drivers and a microstepping indexer, and is intended to drive a bipolar stepper motor. The output driver block consists of N-channel power MOSFET's configured as full H-bridges to drive the motor windings. The TMI8420/Q is capable of driving up to 2.5-A of current from each output.

A simple STEP/DIR interface allows easy interfacing to controller circuits. Mode pins allow for configuration of the motor in full-step up to 1/32-step modes. Decay mode is configurable so that slow decay, fast decay, or mixed decay can be used. A low-power sleep mode is provided which shuts down internal circuitry to achieve very low quiescent current draw. This sleep mode can be set using a dedicated nSLEEP pin.

The TMI8420/Q which comply with ROHS specifications, and the lead frame is 100% lead-free.

TYPICAL APPLICATION

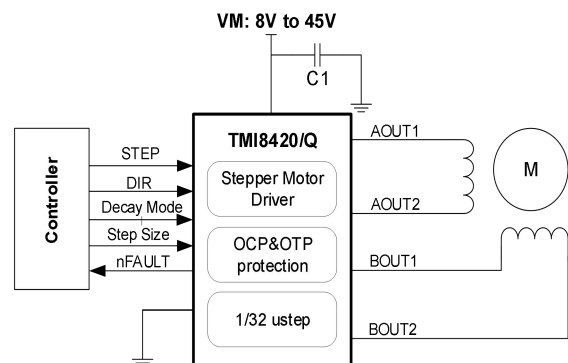

Figure 1. Basic Application Circuit

ABSOLUTE MAXIMUM RATINGS (Note 1)

Parameter	Min	Max	Unit
Power supply voltage (VM)	-0.3	48	V
Power supply ramp rate (VMx)		1	V/ μ s
Digital pin voltage	-0.5	7	V
Reference input pin voltage (VREF)	-0.3	4	V
Continuous motor drive output current	0	2.5	A
Operating ambient temperature, T _A	-40	85	°C
Operating virtual junction temperature, T _J	-40	150	°C
Storage temperature, T _{stg}	-60	150	°C

ESD RATING

Items	Description	Value	Unit
V _{ESD}	Human body model	\pm 2000	V
	Charged device model (CDM)	\pm 750	V

PACKAGE/ORDER INFORMATION

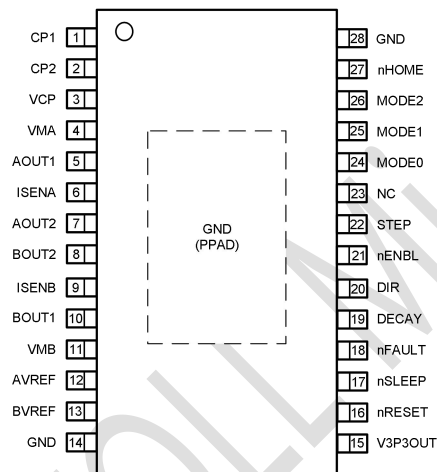

HTSSOP28(Top view)
TMI8420

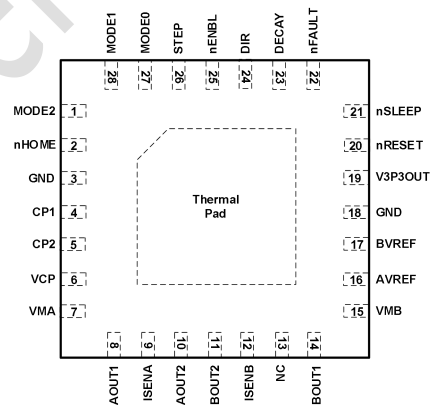

QFN5*5-28(Top view)
TMI8420Q

TMI8420/XXXXX (TMI8420: Device Code, XXXXX: Inside Code) for TMI8420

Part Number	Package	Top mark	Quantity/ Reel
TMI8420	HTSSOP28	TMI8420 XXXXX	4500
TMI8420Q	QFN5*5-28	TMI8420Q XXXXX	5000

The TMI8420/Q device is Pb-free and RoHS compliant.

PIN FUNCTIONS

Pin		Name	I/O ^(Note2)	Function
HTSSOP	QFN			
14、28	3、18	GND	-	Device ground.
4	7	VMA	-	Bridge A power supply, Connect a 0.1μF bypass capacitor to ground, as well as a sufficient bulk capacitance rated for VM.
11	15	VMB	-	Bridge B power supply. Connect a 0.1μF bypass capacitor to ground, as well as a sufficient bulk capacitance rated for VM.
15	19	V3P3OUT	O	3.3V regulator output.
1	4	CP1	I/O	Charge pump flying capacitor, Connect a 0.01-μF 50-V capacitor between CP1 and CP2
2	5	CP2	I/O	
3	6	VCP	I/O	High-side gate drive voltage. Connect a 0.1μF ceramic capacitor and 1-MΩ resistor to VM.
21	25	nENBL	I	Enable input, Logic high to disable device outputs and indexer operation, logic low to enable. Internal pull-down.
20	24	DIR	I	Direction input, Level sets the direction of stepping. Internal pull-down
24	27	MODE0	I	MODE0 through MODE2 set the step mode - full, 1/2, 1/4, 1/8, 1/16, or 1/32 step. Internal pull-down.
25	28	MODE1	I	
26	1	MODE2	I	
22	26	STEP	I	Step input, Rising edge causes the indexer to move one step. Internal pull-down
23	13	NC		No connect, Leave this pin unconnected.
27	2	nHOME	OD	Home position, Logic low when at home state of step table
19	23	DECAY	I	Decay mode. Low = slow decay, open = mixed decay, high = fast decay.
16	20	nRESET	I	Reset input. Active-low reset input initializes internal logic and disables the H-bridge outputs.
17	21	nSLEEP	I	Sleep mode input. Logic high to enable device, logic low to enter low-power sleep mode.
12	16	AVREF	I	Bridge A current set reference input.
13	17	BVREF	I	Bridge B current set reference input.
18	22	nFAULT	OD	Fault. Logic low when in fault condition
6	9	ISENA	I/O	Bridge A ground / Isense. Connect to current sense resistor for bridge A.

PIN FUNCTIONS(Continued)

Pin			I/O ^(Note2)	Function
HTSSOP	QFN	Name		
9	12	ISENB	I/O	Bridge B ground / Isense. Connect to current sense resistor for bridge B.
5	8	AOUT1	O	Bridge A output 1.
7	10	AOUT2	O	Bridge A output 2.
10	14	BOUT1	O	Bridge B output 1.
8	11	BOUT2	O	Bridge B output 2.

RECOMMENDED OPERATING CONDITIONS

Items	Description	Min	Max	Unit
VM	Power supply voltage range ^(Note3)	8.0	45	V
VREF	VREF input voltage ^(Note4)	1	3.5	V
IV3P3	V3P3OUT load current		10	mA
f _{PWM}	Externally applied PWM frequency	0	100	kHz

Note 1: Absolute Maximum Ratings are those values beyond which the life of a device may be impaired.

Note2: Directions: I = input, O = output, OD = open-drain output, IO = input/output.

Note3: All VM pins must be connected to the same supply voltage.

Note4: Operational at VREF between 0V and 1V, but accuracy is degraded.

ELECTRICAL CHARACTERISTICS

T_A = 25°C, over recommended operating conditions (unless otherwise noted)

PARAMETER	SYMBOL	TEST CONDITIONS	MIN	TYP	MAX	UNIT
POWER SUPPLY						
VM operating supply current	I _{VM}	VM = 24 V, f _{PWM} < 50 kHz		2	5	mA
VM sleep mode supply current	I _{VMQ}	VM = 24V		1	10	μA
VM undervoltage lockout voltage	V _{UVLO}	VM rising		6	8	V
V3P3OUT voltage	V _{3P3}	IOUT = 0 to 1mA, VM = 24 V, T _J = 25°C	3.18	3.30	3.40	V
		IOUT = 0 to 1mA	3.10	3.30	3.50	V
	V _{3P3UVLO}			2		V
LOGIC-LEVEL INPUTS						
Input low voltage	V _{IL}			0.7	0.8	V
Input high voltage	V _{IH}		1.8		5.25	V
Input hysteresis	V _{HYS}			0.45		V
Input low current	I _{IL}	V _{IN} = 0V	-20		20	μA
Input high current	I _{IH}	V _{IN} = 3.3V		35	50	μA
Pulldown resistance	R _{PD}			100		kΩ
nFAULT OUTPUT (OPEN-DRAIN OUTPUT)						
output low voltage	V _{OL}	I _o = 5mA			0.5	V
output high leakage current	I _{OH}	V _o = 3.3 V			1	μA
DECAY INPUT						
Input low threshold voltage	V _{IL}	For slow decay mode	0		1.2	V
Input high threshold voltage	V _{IH}	For fast decay mode	1.8			V
Input current		Decay = 5V			±70	μA
Pullup resistance(to 3.3V)	R _{PU}			130		kΩ
Pulldown resistance	R _{PD}			80		kΩ
H-BRIDGE FETS						
HS FET on resistance	R _{DS(ON)}	VM = 24 V, I _o = 1 A		0.2		Ω
LS FET on resistance	R _{DS(ON)}	VM = 24 V, I _o = 1 A		0.2		Ω
Off-state leakage current	I _{OFF}		-10		10	μA
MOTOR DRIVER						
Internal PWM frequency	f _{PWM}			30		kHz
Current sense blanking time	t _{BLANK}			4		μs
Rise time	t _R	VM = 24 V	20		200	ns
Fall time	t _F	VM = 24 V	20		200	ns
Dead time	t _{DEAD}			400		ns
Input deglitch time	t _{DEG}		1.7		2.5	μs

ELECTRICAL CHARACTERISTICS (Continued)

T_A = 25°C, over recommended operating conditions (unless otherwise noted)

PARAMETER	SYMBOL	TEST CONDITIONS	MIN	TYP	MAX	UNIT
CURRENT CONTROL						
xVREF input current	IREF	xVREF = 3.3 V	-3		3	μA
xISENSE trip voltage	V _{TRIP}	V(xVREF)=3.3V, 100% current setting	635	660	685	mV
xISENSE current trip accuracy	ΔI _{TRIP}	xVREF=3.3V, 5% current setting	-25		25	%
		xVREF=3.3V, 10%-34% current setting	-15		15	%
		xVREF=3.3V, 38%-67% current setting	-10		10	%
		xVREF=3.3V, 71%-100% current setting	-5		5	%
Current sense amplifier gain	A _{ISENSE}	Reference only		5		V/V
PROTECTION CIRCUITS						
Overcurrent protection trip level	I _{OC}		4	4.5	5	A
Overcurrent deglitch time	t _{DEG}			3		μs
Thermal shutdown temperature	T _{SD} (Note3)		150	170	180	°C
Thermal shutdown hysteresis	T _{HYS} (Note 4)			30		°C

Note 1: Absolute Maximum Ratings are those values beyond which the life of a device may be impaired.

Note 2: T_J is calculated from the ambient temperature T_A and power dissipation P_D according to the following formula: T_J = T_A + P_D × θ_{JA}. The maximum allowable continuous power dissipation at any ambient temperature is calculated by P_{D (MAX)} = (T_{J(MAX)} - T_A) / θ_{JA}.

Note 3: Thermal shutdown threshold and hysteresis are guaranteed by design.

OPERATION

Overview

The TMI8420/Q provides an integrated motor driver solution for printers, scanners, and other automated equipment applications. The device has two H-bridge drivers and a microstepping indexer, and is intended to drive a bipolar stepper motor. The output driver block consists of N-channel power MOSFET's configured as full H-bridges to drive the motor windings. The TMI8420/Q is capable of driving up to 2.5 A of current from each output (with proper heat sinking, at 24 V and 25°C).

A simple STEP/DIR interface allows easy interfacing of the motor in full-step up to 1/32-step modes. Decay mode is configurable so that slow decay, fast decay, or mixed decay can be used. A low-power sleep mode is provided which shuts down internal circuitry to achieve very low quiescent current draw. This sleep mode can be set using a dedicated nSLEEP pin.

Internal shutdown functions are provided for overcurrent, short circuit, under voltage lockout and over temperature. Fault conditions are indicated via the nFAULT pin.

Control Modes

Built-in indexer logic in the TMI8420/Q allows a number of different stepping configurations. The MODE0 through MODE2 pins are used to configure the stepping format as shown in Table 1.

Table 1. Stepping Format

MODE2	MODE1	MODE0	STEP MODE
0	0	0	Full step (2-phase excitation) with 71% current
0	0	1	1/2 step (1-2 phase excitation)
0	1	0	1/4 step (W1-2 phase excitation)
0	1	1	8 microsteps/step
1	0	0	16 microsteps/step
1	0	1	32 microsteps/step
1	1	0	32 microsteps/step
1	1	1	32 microsteps/step

Table 2 shows the relative current and step directions for different settings of MODEx. At each rising edge of the STEP input, the indexer travels to the next state in the table. The direction is shown with the DIR pin high; if the DIR pin is low the sequence is reversed. Positive current is defined as xOUT1 = positive with respect to xOUT2.

Table 2. Relative Current and Step Directions

1/32 STEP	1/16 STEP	1/8 STEP	1/4 STEP	1/2 STEP	FULL STEP 70%	WINDING CURRENT A	WINDING CURRENT B	ELECTRICAL ANGLE
1	1	1	1	1		100%	0%	0
2						100%	5%	3
3	2					100%	10%	6
4						99%	15%	8
5	3	2				98%	20%	11
6						97%	24%	14
7	4					96%	29%	17
8						94%	34%	20
9	5	3	2			92%	38%	23
10						90%	43%	25
11	6					88%	47%	28
12						86%	51%	31
13	7	4				83%	56%	34
14						80%	60%	37
15	8					77%	63%	39
16						74%	67%	42
17	9	5	3	2	1	71%	71%	45
18						67%	74%	48
19	10					63%	77%	51
20						60%	80%	53
21	11	6				56%	83%	56
22						51%	86%	59
23	12					47%	88%	62
24						43%	90%	65
25	13	7	4			38%	92%	68
26						34%	94%	70
27	14					29%	96%	73
28						24%	97%	76
29	15	8				20%	98%	79
30						15%	99%	82
31	16					10%	100%	84
32						5%	100%	87
33	17	9	5	3		0%	100%	90
34						-5%	100%	93
35	18					-10%	100%	96
36						-15%	99%	98
37	19	10				-20%	98%	101
38						-24%	97%	104

Table 2. Relative Current and Step Directions (continued)

1/32 STEP	1/16 STEP	1/8 STEP	1/4 STEP	1/2 STEP	FULL STEP 70%	WINDING CURRENT A	WINDING CURRENT B	ELECTRICAL ANGLE
39	20					-29%	96%	107
40						-34%	94%	110
41	21	11	6			-38%	92%	113
42						-43%	90%	115
43	22					-47%	88%	118
44						-51%	86%	121
45	23	12				-56%	83%	124
46						-60%	80%	127
47	24					-63%	77%	129
48						-67%	74%	132
49	25	13	7	4	2	-71%	71%	135
50						-74%	67%	138
51	26					-77%	63%	141
52						-80%	60%	143
53	27	14				-83%	56%	146
54						-86%	51%	149
55	28					-88%	47%	152
56						-90%	43%	155
57	29	15	8			-92%	38%	158
58						-94%	34%	160
59	30					-96%	29%	163
60						-97%	24%	166
61	31	16				-98%	20%	169
62						-99%	15%	172
63	32					-100%	10%	174
64						-100%	5%	177
65	33	17	9	5		-100%	0%	180
66						-100%	-5%	183
67	34					-100%	-10%	186
68						-99%	-15%	188
69	35	18				-98%	-20%	191
70						-97%	-24%	194
71	36					-96%	-29%	197
72						-94%	-34%	200
73	37	19	10			-92%	-38%	203
74						-90%	-43%	205
75	38					-88%	-47%	208
76						-86%	-51%	211

Table 2. Relative Current and Step Directions (continued)

1/32 STEP	1/16 STEP	1/8 STEP	1/4 STEP	1/2 STEP	FULL STEP 70%	WINDING CURRENT A	WINDING CURRENT B	ELECTRICAL ANGLE
77	39	20				-83%	-56%	214
78						-80%	-60%	217
79	40					-77%	-63%	219
80						-74%	-67%	222
81	41	21	11	6	3	-71%	-71%	225
82						-67%	-74%	228
83	42					-63%	-77%	231
84						-60%	-80%	233
85	43	22				-56%	-83%	236
86						-51%	-86%	239
87	44					-47%	-88%	242
88						-43%	-90%	245
89	45	23	12			-38%	-92%	248
90						-34%	-94%	250
91	46					-29%	-96%	253
92						-24%	-97%	256
93	47	24				-20%	-98%	259
94						-15%	-99%	262
95	48					-10%	-100%	264
96						-5%	-100%	267
97	49	25	13	7		0%	-100%	270
98						5%	-100%	273
99	50					10%	-100%	276
100						15%	-99%	278
101	51	26				20%	-98%	281
102						24%	-97%	284
103	52					29%	-96%	287
104						34%	-94%	290
105	53	27	14			38%	-92%	293
106						43%	-90%	295
107	54					47%	-88%	298
108						51%	-86%	301
109	55	28				56%	-83%	304
110						60%	-80%	307
111	56					63%	-77%	309
112						67%	-74%	312
113	57	29	15	8	4	71%	-71%	315
114						74%	-67%	318

Table 2. Relative Current and Step Directions (continued)

1/32 STEP	1/16 STEP	1/8 STEP	1/4 STEP	1/2 STEP	FULL STEP 70%	WINDING CURRENT A	WINDING CURRENT B	ELECTRICAL ANGLE
115	58					77%	-63%	321
116						80%	-60%	323
117	59	30				83%	-56%	326
118						86%	-51%	329
119	60					88%	-47%	332
120						90%	-43%	335
121	61	31	16			92%	-38%	338
122						94%	-34%	340
123	62					96%	-29%	343
124						97%	-24%	346
125	63	32				98%	-20%	349
126						99%	-15%	352
127	64					100%	-10%	354
128						100%	-5%	357

Current Regulation

In TMI8420/Q, motor peak current can be limited by the analog reference input VREF and the resistance of external sense resistor on the SENSEx pin approximately according to the below equation:

$$I_{\text{CHOP}} \text{ (A)} = \frac{V_{\text{REF}} \text{ (V)}}{A_V \times R_{\text{ISEN}} \text{ (}\Omega\text{)}} = \frac{V_{\text{REF}} \text{ (V)}}{5 \times R_{\text{ISEN}} \text{ (}\Omega\text{)}}$$

For example:

If VREF = 3.3 V and a RISEN = 0.5 Ω, the TMI8420/Q full-scale (100%) chopping current will be 1.32A;

Decay Mode

During PWM current chopping, the H-bridge is enabled to drive current through the motor winding until the PWM current chopping threshold is reached. This is shown in Figure 2 as case 1. The current flow direction shown indicates positive current flow.

Once the chopping current threshold is reached, the H-bridge can operate in two different states, fast decay or slow decay.

In fast decay mode, once the PWM chopping current level has been reached, the H-bridge reverses state to allow winding current to flow in a reverse direction. As the winding current approaches zero, the bridge is disabled to prevent any reverse current flow. Fast decay mode is shown in Figure 2 as case 2.

In slow decay mode, winding current is re-circulated by enabling both of the low-side FETs in the bridge. This is shown in Figure 2 as case 3.

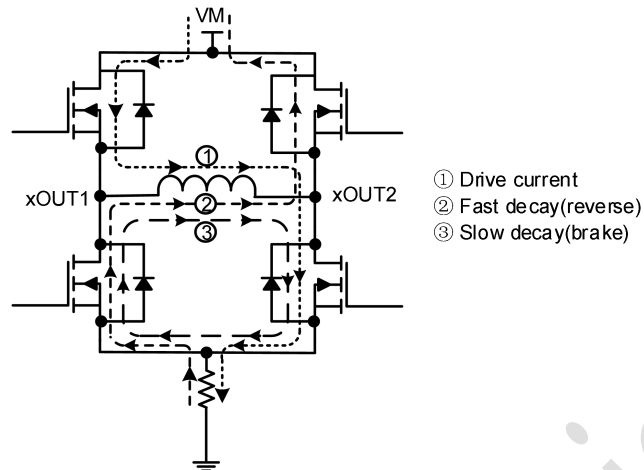

Figure 2. Decay Mode

The TMI8420/Q supports fast decay, slow decay and a mixed decay mode. Slow, fast, or mixed decay mode is selected by the state of the DECAY pin - logic low selects slow decay, open selects mixed decay operation, and logic high sets fast decay mode. The DECAY pin sets the decay mode for both H-bridges.

Mixed decay mode begins as fast decay, but at a fixed period of time (75% of the PWM cycle) switches to slow decay mode for the remainder of the fixed PWM period.

VM Undervoltage Lockout (UVLO)

If at any time the voltage on the VM pin falls below the undervoltage-lockout threshold voltage, all FETs in the H-bridge will be disabled. Operation resumes when VM rises above the UVLO threshold.

Overcurrent Protection (OCP)

An analog current limit circuit on each FET limits the current through the FET by removing the gate drive. If this analog current limit persists for longer than the OCP time, all FETs in the H-bridge will be disabled and the nFAULT pin will be driven low. The device will remain disabled until either nRESET pin is applied, or VM is removed and reapplied.

Overcurrent conditions on both high and low side devices; that is, a short to ground, supply, or across the motor winding will all result in an overcurrent shutdown. Note that overcurrent protection does not use the current sense circuitry used for PWM current control, and is independent of the ISENSE resistor value or VREF voltage

Thermal Shutdown (TSD)

If the die temperature exceeds safe limits, all FETs in the H-bridge are disabled. After the die temperature has fallen to a safe level, operation automatically resumes.

VM Control

In some systems, varying VM as a means of changing motor speed is desirable.

Application Curves

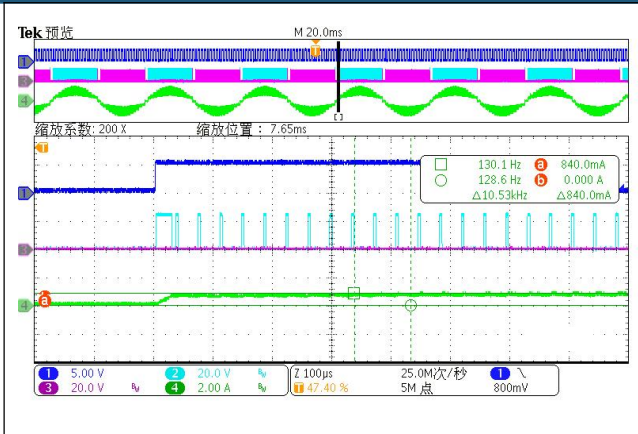

TMI8420/Q Slow decay waveform

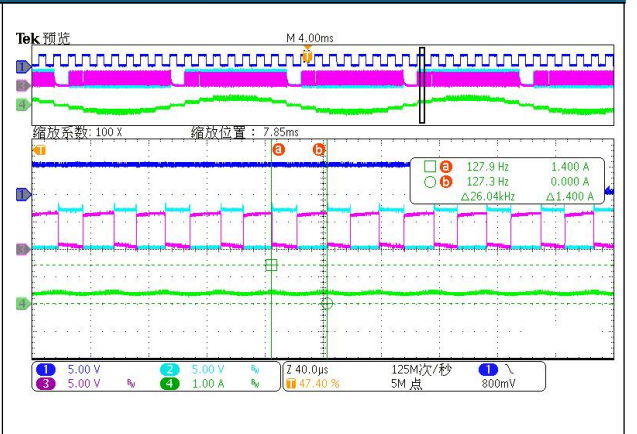

TMI8420/Q Fast decay waveform

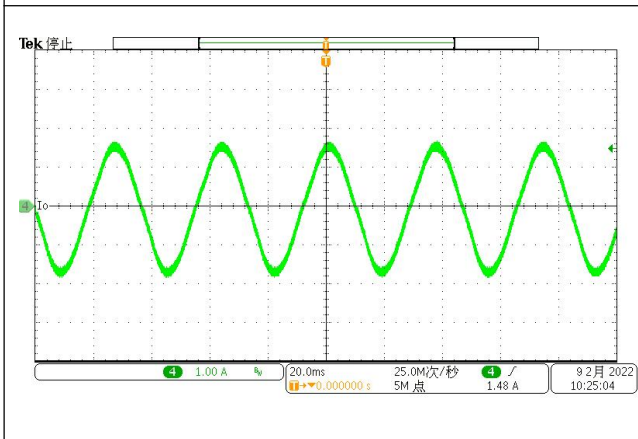

TMI8420/Q Drive Stepper Motor

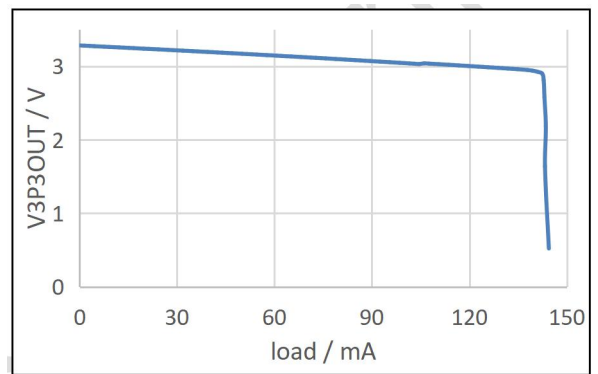

TMI8420/Q V3OUT3 Load Capacity

APPLICATION INFORMATION

Application information

The TMI8420/Q is used in bipolar stepper control. The microstepping motor driver provides additional precision and a smooth rotation from the stepper motor. The following design is a common application of the TMI8420/Q.

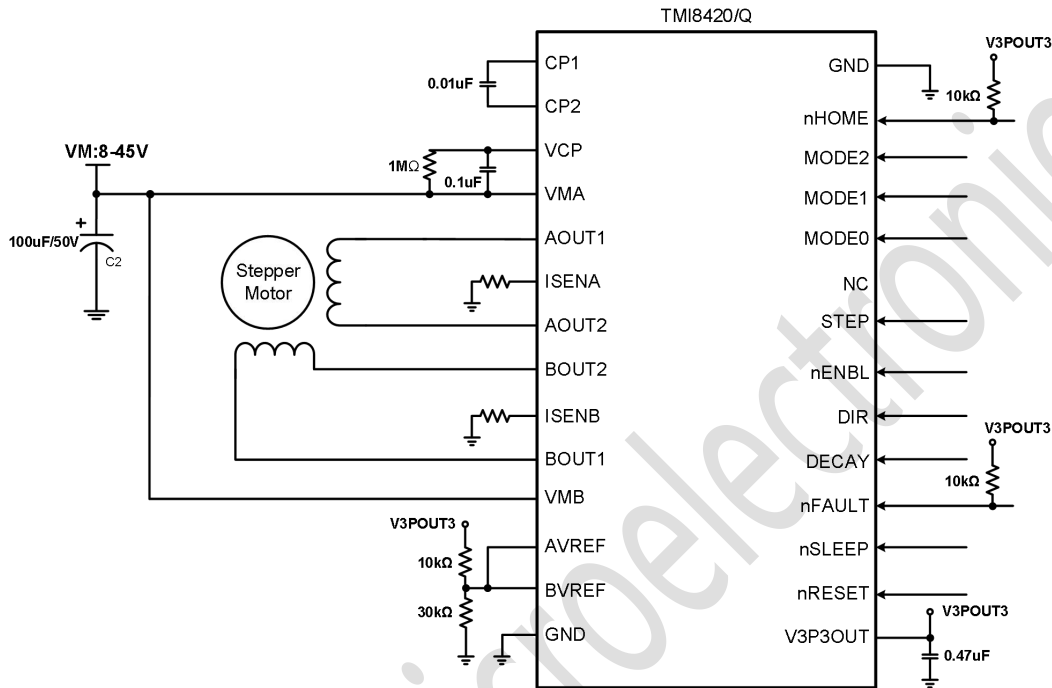

Figure 3. TMI8420/Q Typical Application

Block Diagram

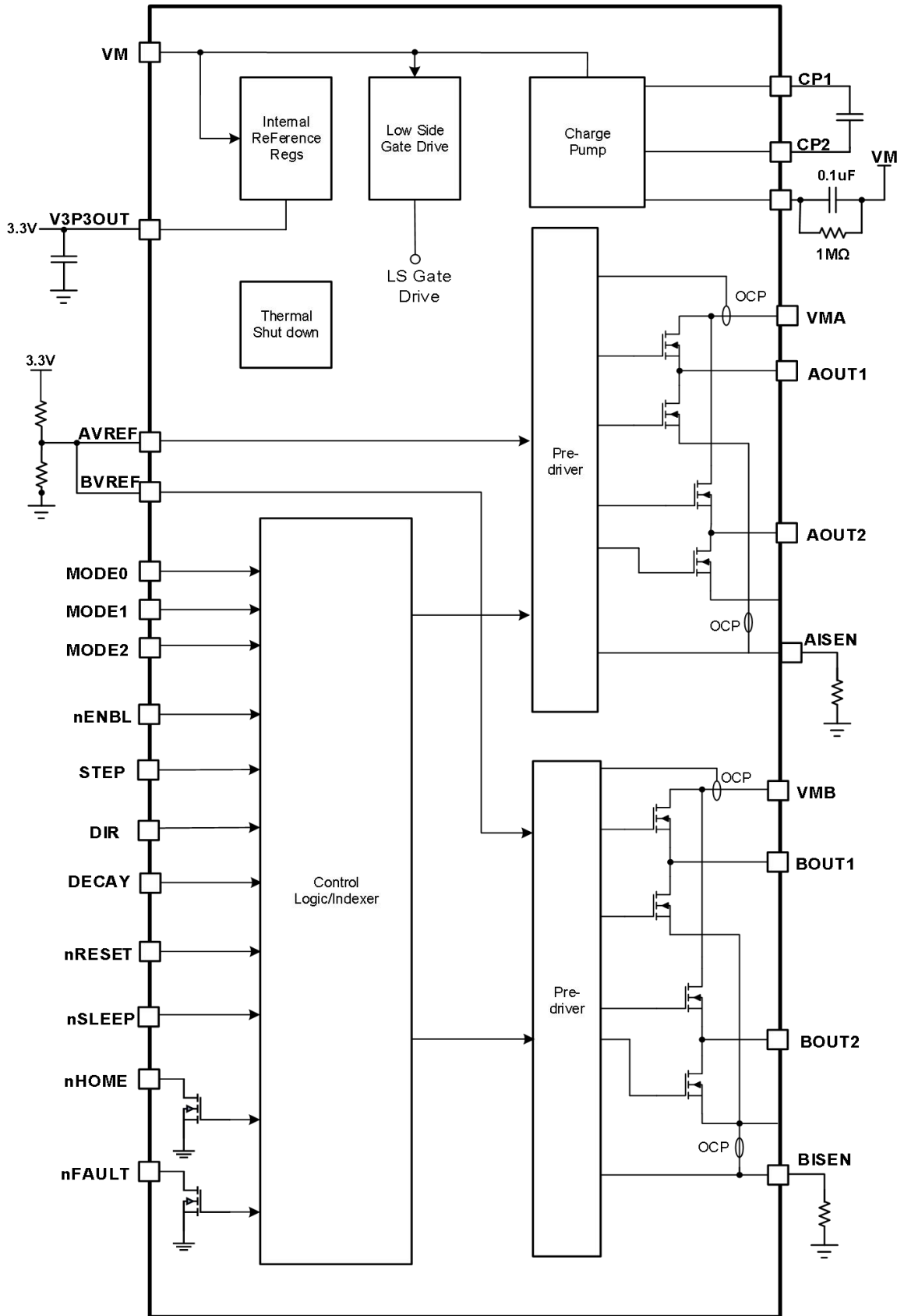
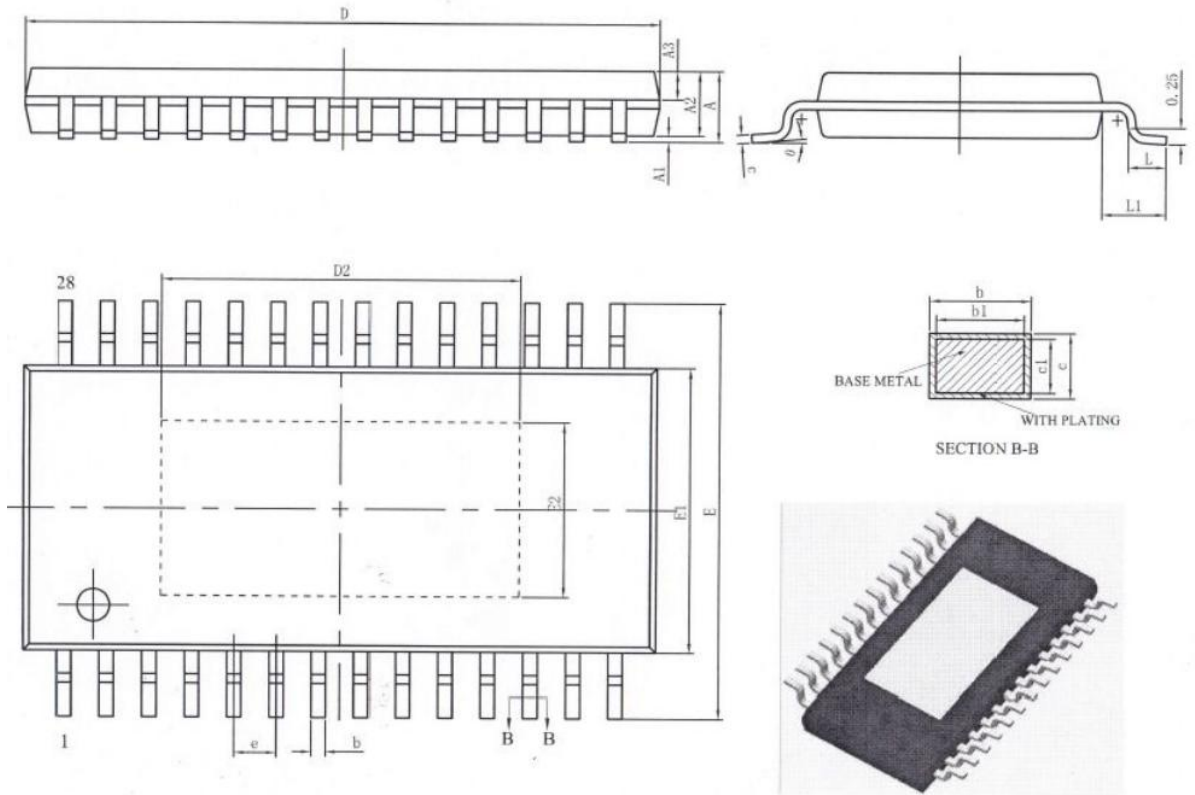

Figure 4. TMI8420/Q Block Diagram

PACKAGE INFORMATION

HTSSOP28



Unit: mm

Symbol	Dimensions In Millimeters			Symbol	Dimensions In Millimeters		
	Min	NOM	Max		Min	NOM	Max
A	-	-	1.20	D2	3.95	4.05	4.15
A1	0.05	-	0.15	E	6.20	6.40	6.60
A2	0.80	-	1.00	E1	4.30	4.40	4.50
A2	0.39	0.44	0.49	E2	2.75	2.85	2.95
b	0.20	-	0.29	e	0.65BSC		
b1	0.19	0.22	0.25	L	0.45	0.60	0.75
c	0.13	-	0.18	L1	1.00BSC		
c1	0.12	0.13	0.15	θ	0°	-	8°
D	9.60	9.70	9.80				

Note:

- 1) All dimensions are in millimeters.
- 2) Package length does not include mold flash, protrusion or gate burr.
- 3) Package width does not include inter lead flash or protrusion.
- 4) Lead popularity (bottom of leads after forming) shall be 0.10 millimeters max.
- 5) Pin 1 is lower left pin when reading top mark from left to right.

TAPE AND REEL INFORMATION

TAPE DIMENSIONS: HTSSOP28

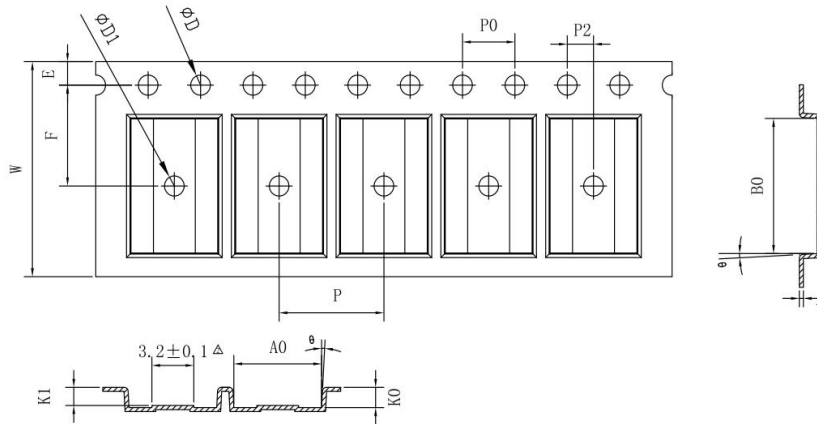

Unit: mm

Symbol	Dimensions	Symbol	Dimensions	Symbol	Dimensions	Symbol	Dimensions
A0	6.70±0.10	θ	5° TYP	E	1.75±0.10	D1	1.55MIN
B0	10.05±0.10	t	0.30±0.05	F	7.50±0.10	P0	0.30±0.10
K0	1.50±0.10	W	16.00±0.30	P2	2.00±0.10	10P0	40.00±0.20
K1	1.35±0.10	P	8.00±0.10	D	1.50±0.10		

REEL DIMENSIONS: HTSSOP28

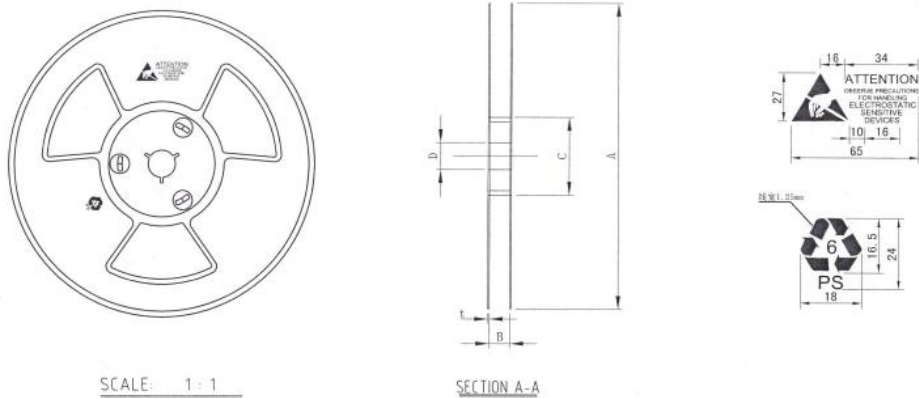

SCALE: 1:1

SECTION A-A

Unit: mm

Ø A	B	Ø C	Ø D	t
329±1.0	16.8±1.0	100±0.5	13.3±0.3	2.0±0.3

Note:

- 1) All Dimensions are in Millimeter
- 2) Quantity of Units per Reel is 4500
- 3) MSL level is level 3.

Important Notification

This document only provides product information. Xi'an TOLL Microelectronic Inc. reserves the right to make corrections, modifications, enhancements, improvements, and other changes to its products and to discontinue any product without notice at any time.

Xi'an TOLL Microelectronic Inc. cannot assume responsibility for use of any circuitry other than circuitry entirely embodied in a TOLL product. No circuit patent licenses are implied.

All rights are reserved by Xi'an TOLL Microelectronic Inc.
[http:// www.toll-semi.com](http://www.toll-semi.com)