

INN040W048A

40V Bi-directional GaN Enhancement-mode Power Transistor

INN040W048A

1. General Description

Bi-directional GaN-on-Silicon enhancement mode high-electron-mobility-transistor (HEMT) in WLCSP with 2.1 mm x 2.1 mm package size.

2. Features

- Bi-directional blocking capability
- GaN-on-Silicon E-mode HEMT technology
- Ultra-low on resistance

3. Applications

- High side load switch
- OVP protection in smart phone USB port
- Switch circuits in multiple power suppliers system

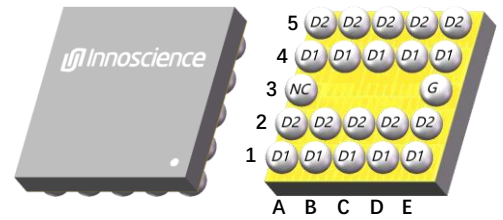
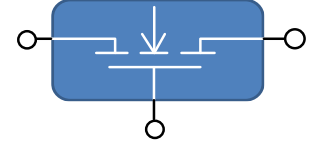

4. Key Performance Parameters

Table 1 Key performance parameters at $T_J = 25\text{ }^\circ\text{C}$

Parameter	Value	Unit
$V_{DD,max}$	40	V
$R_{D1D2(on),max}$ @ $V_G = 5\text{ V}$	4.8	m Ω
$Q_{G,typ}$ @ $V_{DD} = 20\text{ V}$	15.8	nC
$I_{D,DC}$	20	A

5. Pin Information

Table 2 Pin information

Pin	Pin description	Pin function
A~E1, A~E4	Drain1	Power Drain1
A~E2, A~E5	Drain2	Power Drain2
E3	Gate	Driver Gate
A3	Not Connected	Dummy Pin

Table 3 Ordering information

Type/Ordering Code	Package	Product Code
INN040W048A	WLCSP 2.1x2.1	D12

Table of contents

1. General Description	1
2. Features	1
3. Applications	1
4. Key Performance Parameters	1
5. Pin Information.....	1
6. Maximum Ratings	3
7. Thermal Characteristics	4
8. Electric Characteristics	5
9. Electric Characteristics Diagrams	7
10.Package Outlines	12
11.Reel Information.....	13
12.Land Pattern.....	14
13.Revision History.....	15

6. Maximum Ratings

at $T_J = 25\text{ °C}$ unless otherwise specified.

Continuous application of maximum ratings can deteriorate transistor lifetime. For further information, contact Innoscience sales office.

Table 4 Maximum ratings

SYMBOL	PARAMETER	MAX	UNIT
V_{DD}	Drain1-to-Drain2 Voltage or Drain2-to-Drain1 Voltage	40	V
V_{DG}	Drain-to-Gate Voltage	40	V
V_{GD}	Gate-to-Drain Voltage	6	V
I_D	Continuous Drain current	20	A
I_{DM}	Pulsed Drain Current (25 °C , $T_{Pulse} = 300\text{ }\mu\text{s}$)	100	A
P_{tot}	Power dissipation ($T_{c, bottom} = 25\text{ °C}$)	13	W
T_J	Operating Temperature	-40 to 125	°C
T_{STG}	Storage Temperature	-40 to 150	°C

7. Thermal Characteristics

Table 5 Thermal characteristics

SYMBOL	PARAMETER	TYP	UNIT
$R_{\theta JC_top}$	Thermal Resistance, Junction to Case (top)	12.6	°C/W
$R_{\theta JC_bot}$	Thermal Resistance, Junction to Case (bottom)	7.6	°C/W
$R_{\theta JA}$	Thermal Resistance, Junction to Ambient ¹	59.3	°C/W

Note 1: $R_{\theta JA}$ is determined with the device mounted on one square inch of copper pad, single layer 2 oz copper on FR4 board.

8. Electric Characteristics

at $T_J = 25\text{ }^\circ\text{C}$, unless specified otherwise

Table 6 Static characteristics

SYMBOL	PARAMETER	MIN	TYP	MAX	UNIT	TEST CONDITIONS
BV_{D1D2S}	Drain1-to-Drain2 Breakdown Voltage	40			V	$V_{D2} = V_G = 0\text{ V}$, $I_{D1D2} = 500\text{ }\mu\text{A}$
BV_{D2D1S}	Drain2-to-Drain1 Breakdown Voltage	40			V	$V_{D1} = V_G = 0\text{ V}$, $I_{D2D1} = 500\text{ }\mu\text{A}$
I_{D1D2S}	Zero Gate Voltage Drain Current			20	μA	$V_{D2} = V_G = 0\text{ V}$, $V_{D1} = 40\text{ V}$
I_{D2D1S}	Zero Gate Voltage Drain Current			20	μA	$V_{D1} = V_G = 0\text{ V}$, $V_{D2} = 40\text{ V}$
I_{GDS} ($T_J = 85\text{ }^\circ\text{C}$)	Gate-to-Drain Leakage		0.5	3	μA	$V_{D1} = V_{D2} = 0\text{ V}$, $V_G = 5\text{ V}$
	Gate-to-Drain Leakage	-30			μA	$V_{D1} = V_{D2} = 0\text{ V}$, $V_G = -5\text{ V}$
I_{GDS} ($T_J = 85\text{ }^\circ\text{C}$)	Gate-to-Drain Leakage		5	30	μA	$V_{D1} = V_{D2} = 0\text{ V}$, $V_G = 6\text{ V}$
	Gate-to-Drain Leakage	-40			μA	$V_{D1} = V_{D2} = 0\text{ V}$, $V_G = -6\text{ V}$
$V_{GD1(TH)}$	Gate Threshold Voltage	0.8		2.4	V	$V_{D1} = 0\text{ V}$, $V_{D2} = V_G$, $I_{D2D1} = 1\text{ mA}$
$V_{GD2(TH)}$	Gate Threshold Voltage	0.8		2.4	V	$V_{D2} = 0\text{ V}$, $V_{D1} = V_G$, $I_{D1D2} = 1\text{ mA}$
$R_{D1D2(on)}$	Drain1-to-Drain2 On-state Resistance		4	4.8	m Ω	$V_{D2} = 0\text{ V}$, $V_{GD} = 5\text{ V}$, $I_{D1D2} = 10\text{ A}$
$R_{D2D1(on)}$	Drain2-to-Drain1 On-state Resistance		4	4.8	m Ω	$V_{D1} = 0\text{ V}$, $V_{GD} = 5\text{ V}$, $I_{D2D1} = 10\text{ A}$

INN040W048A

40V Bi-directional GaN Enhancement-mode Power Transistor

Table 7 Dynamic characteristics

SYMBOL	PARAMETER	MIN	TYP	MAX	UNIT	TEST CONDITIONS
C _{ISS}	Input Capacitance		887		pF	V _G = 0 V, V _D = 20 V
C _{OSS}	Output Capacitance		381			
C _{RSS}	Reverse Transfer Capacitance		226			
R _G	Gate Resistance		4.1		Ω	f = 1 MHz
Q _G	Total Gate Charge		15.8		nC	V _D = 20 V, V _G = 5 V, I _D = 10 A
Q _{GD1}	Gate-to-Drain1 Charge (V _{D2D1} =20V)		1.9			V _{D1} = 0, V _{D2} = 20 V, I _{D2D1} = 10 A
Q _{GD1}	Gate-to-Drain1 Charge (V _{D1D2} =20V)		8.6			V _{D2} = 0, V _{D1} = 20 V, I _{D1D2} = 10 A
Q _{GD2}	Gate-to-Drain2 Charge (V _{D1D2} =20V)		1.9			V _{D2} = 0, V _{D1} = 20 V, I _{D1D2} = 10 A
Q _{GD2}	Gate-to-Drain2 Charge (V _{D2D1} =20V)		8.6			V _{D1} = 0, V _{D2} = 20 V, I _{D2D1} = 10 A
Q _{OSS}	Output Charge		12.2			V _G = 0 V, V _D = 20 V

9. Electric Characteristics Diagrams

at $T_J = 25\text{ }^\circ\text{C}$, unless specified otherwise

Note: In Charts, VD1D2 can be VD2D1 with same characteristic chart due to Bi-directional feature.

Figure 1 Typical Output Characteristics ($T_J = 25\text{ }^\circ\text{C}$)

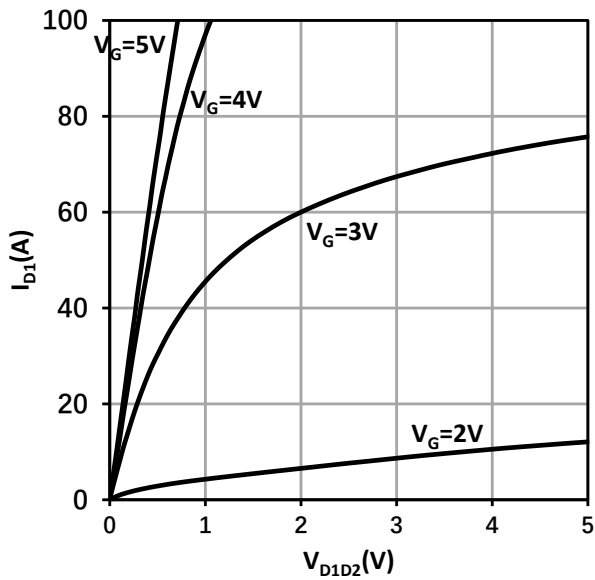

Figure 2 Typical Output Characteristics ($T_J = 125\text{ }^\circ\text{C}$)

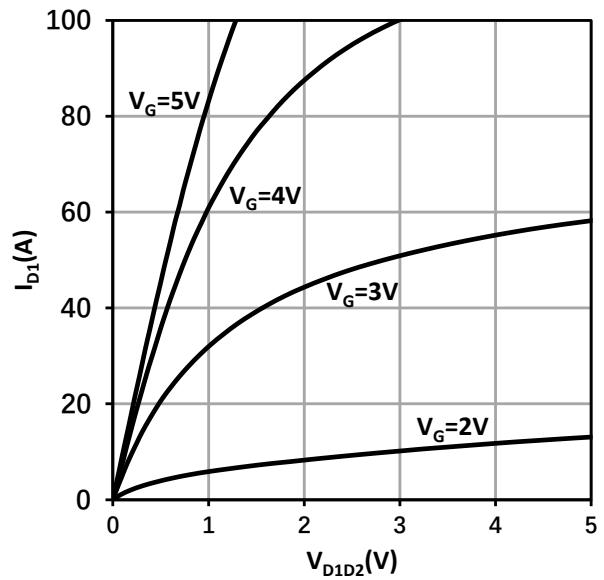

Figure 3 Typical Drain On-state Resistance

($T_J = 25\text{ }^\circ\text{C}$)

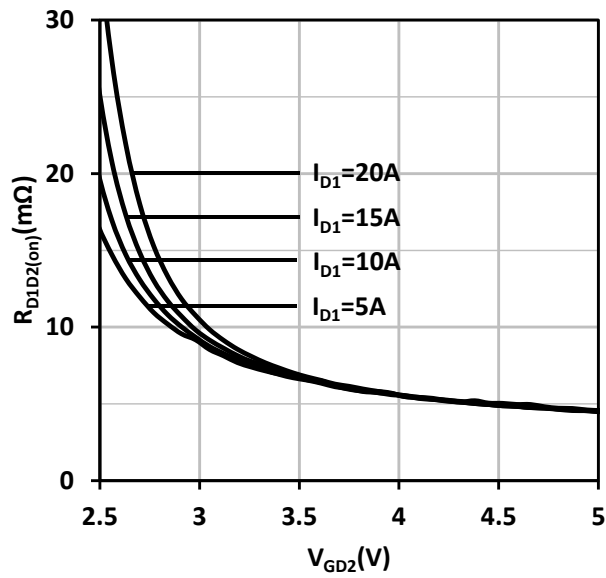
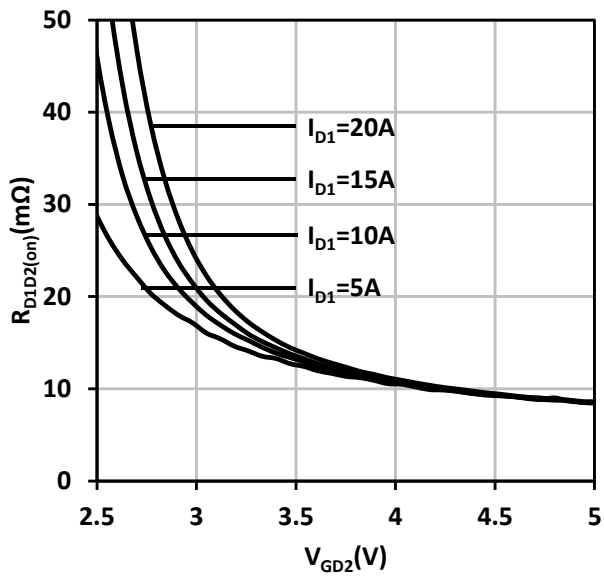

Figure 4 Typical Drain On-state Resistance

($T_J = 125\text{ }^\circ\text{C}$)



INN040W048A

40V Bi-directional GaN Enhancement-mode Power Transistor

Figure 5 Typical On Resistance vs. Temperature

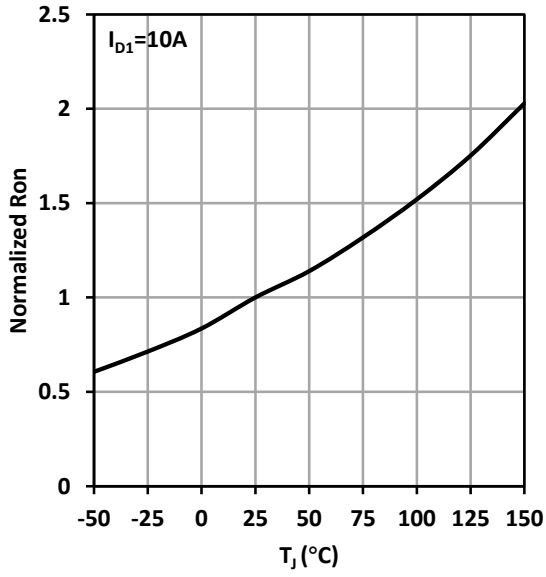

Figure 6 Typical Transfer Characteristics

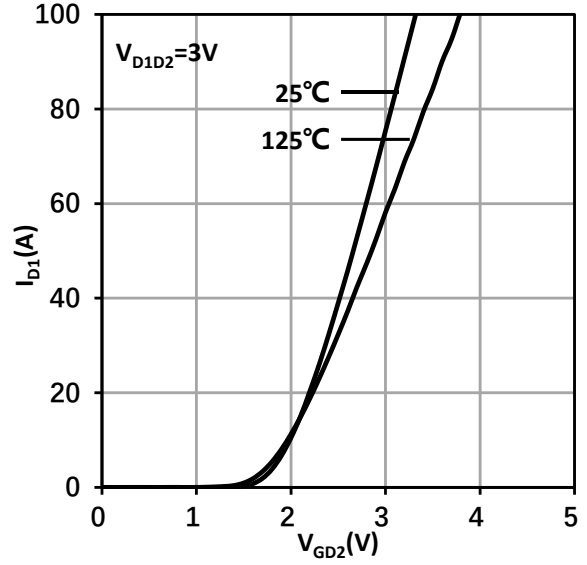

Figure 7 Typ. Reverse Drain1- Drain2 Characteristics ($V_{GD2} \leq 0V$, $T_J = 25^\circ C$)

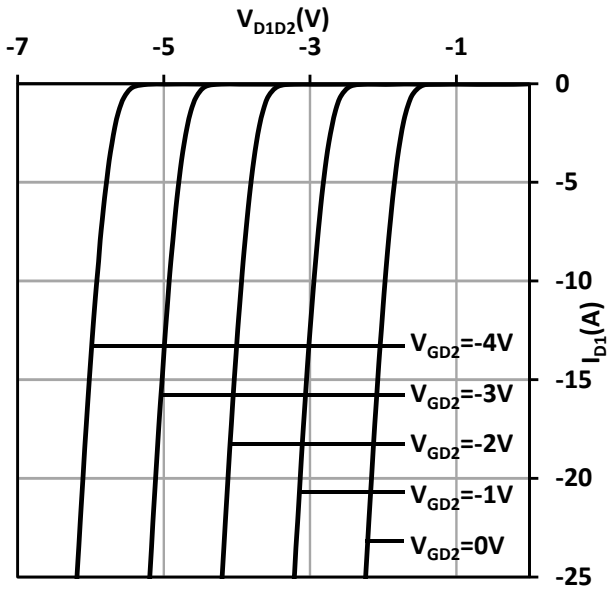
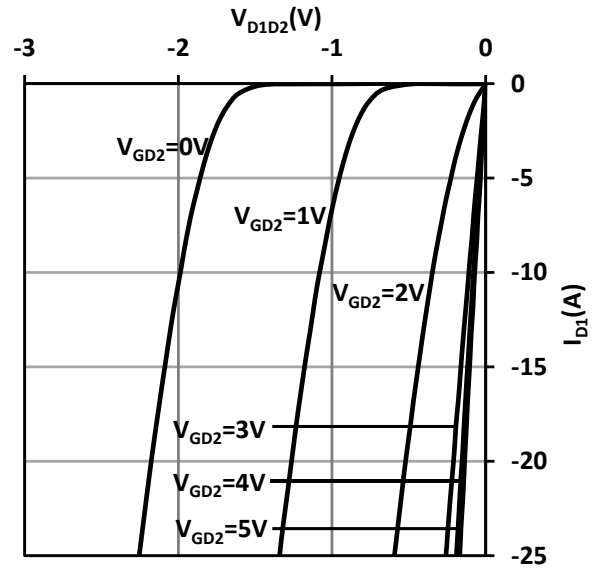

Figure 8 Typ. Reverse Drain1- Drain2 Characteristics ($V_{GD2} \geq 0V$, $T_J = 25^\circ C$)



INN040W048A

40V Bi-directional GaN Enhancement-mode Power Transistor

Figure 9 Typ. Reverse Drain1- Drain2 Characteristics ($V_{GD2} \leq 0V$, $T_J = 125^\circ C$)

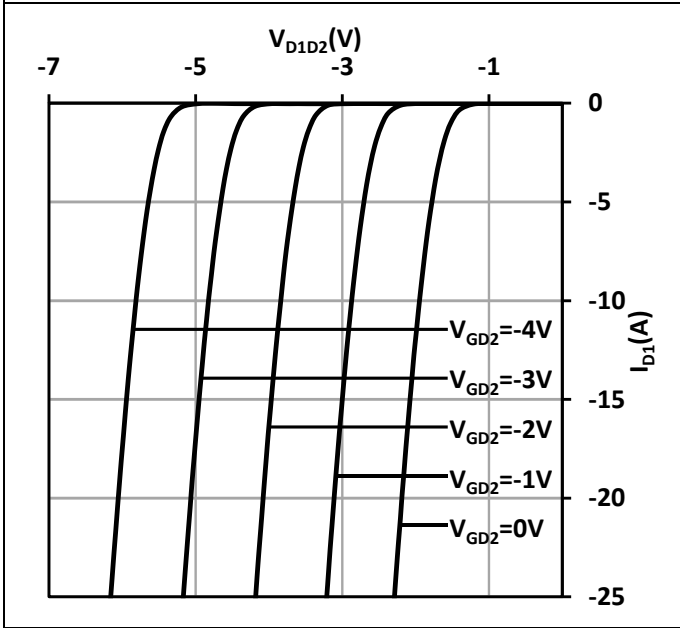

Figure 10 Typ. Reverse Drain1-Drain2 Characteristics ($V_{GD2} \geq 0V$, $T_J = 125^\circ C$)

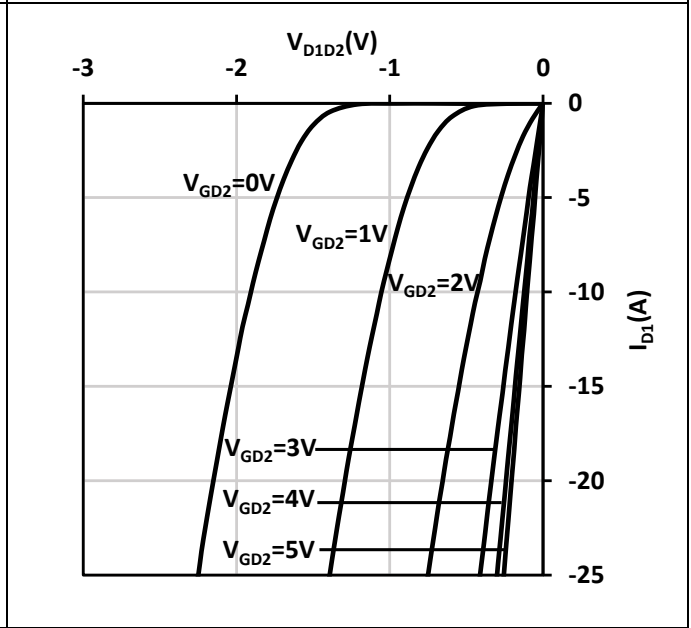

Figure 11 Typical Capacitances Characteristics

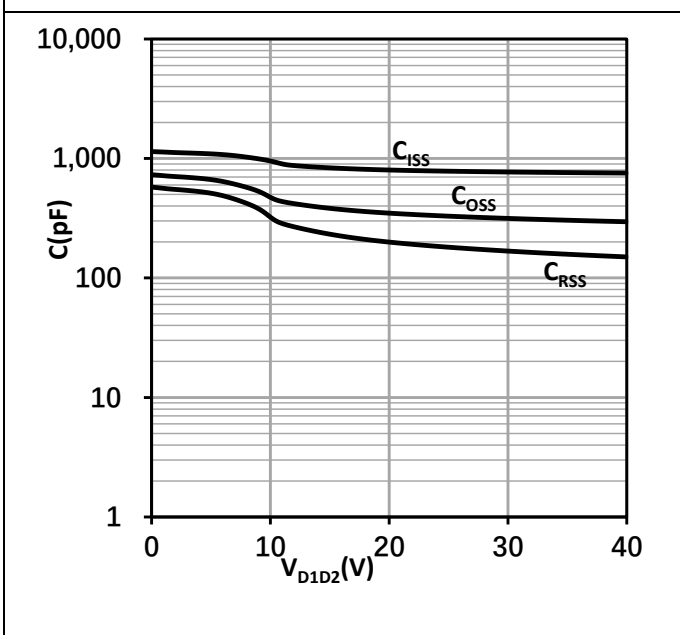

Figure 12 Typical Gate Charge

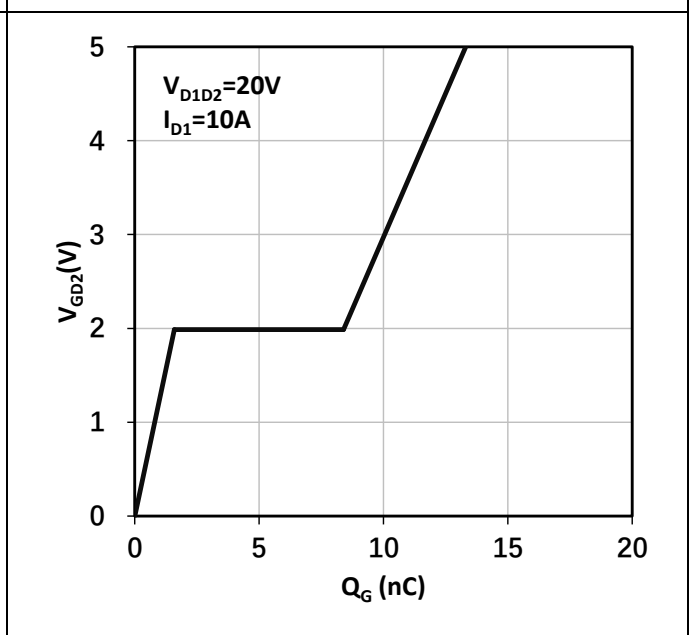

Figure 13 Normalized Threshold Voltage vs. Temp.

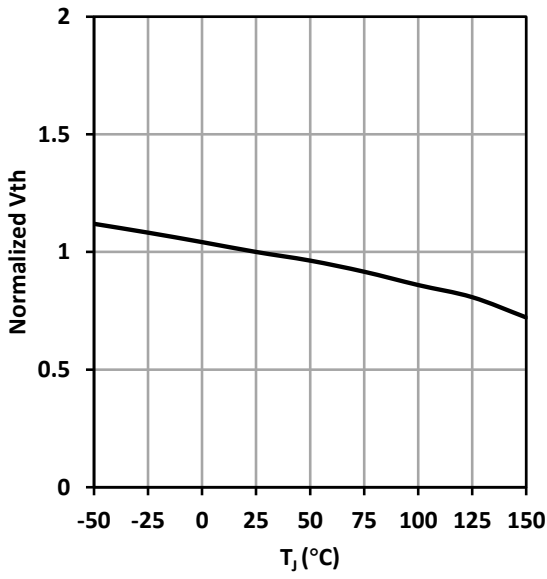

Figure 14 Output Charge

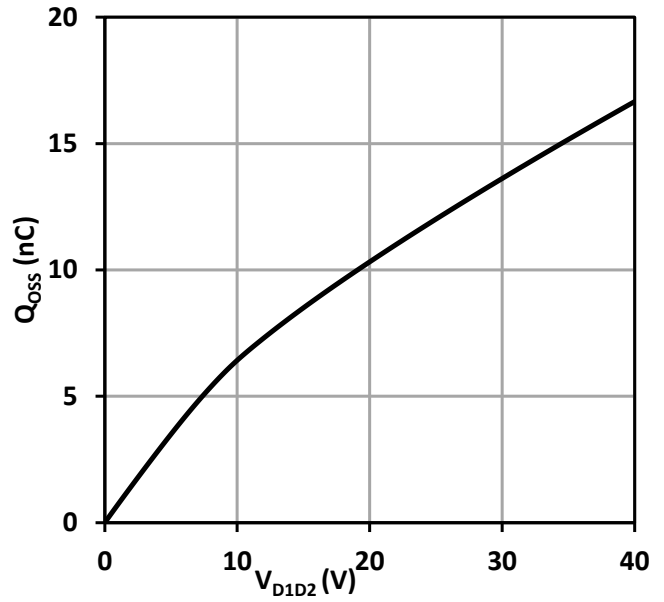

Figure 15 Output Capacitance Stored Energy

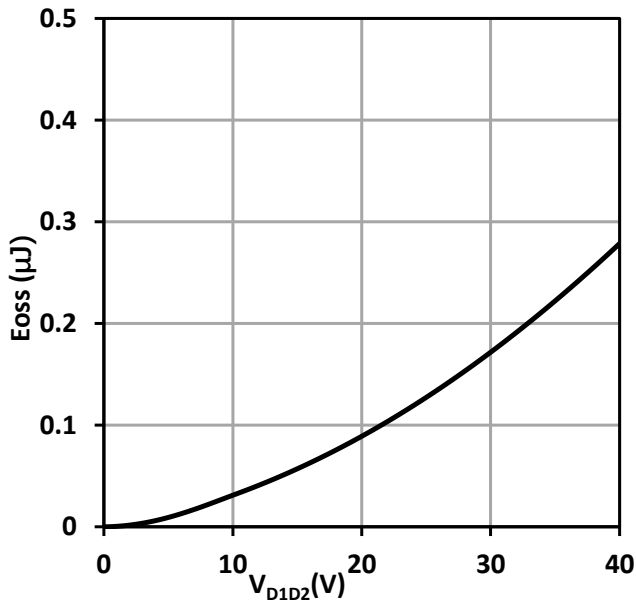
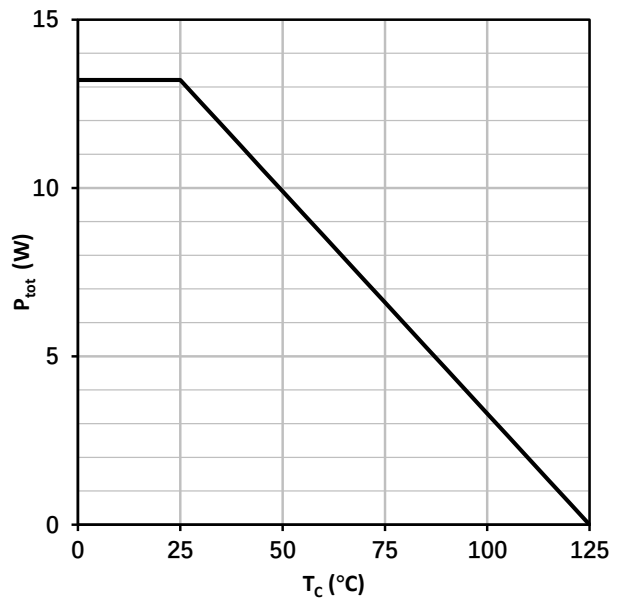

Figure 16 Power Dissipation



INN040W048A

40V Bi-directional GaN Enhancement-mode Power Transistor

Figure 17 Safe Operating Area

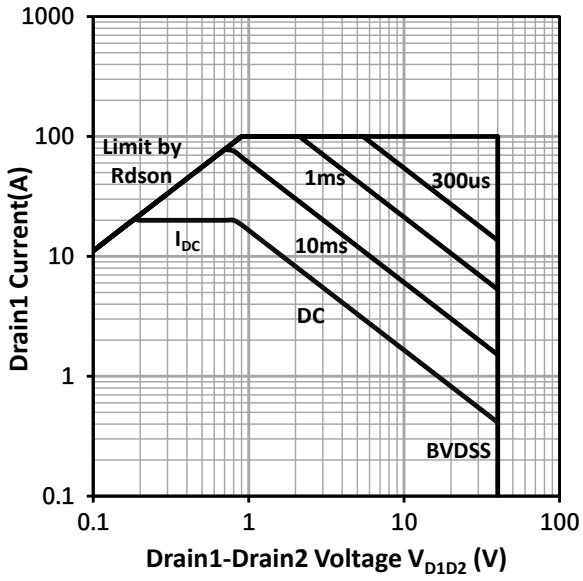
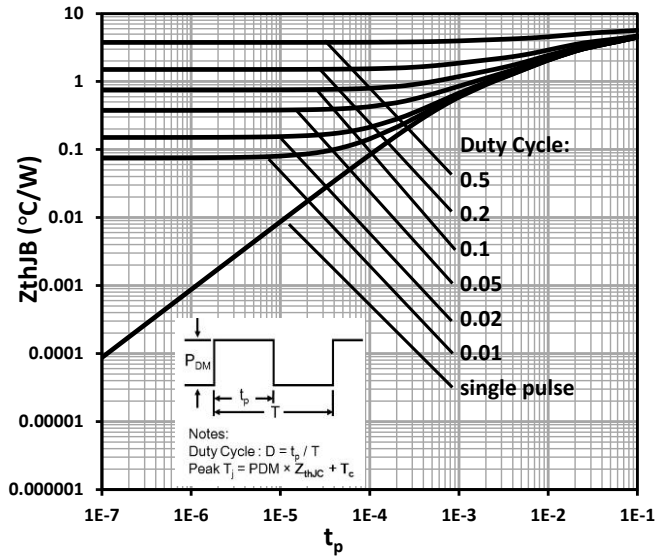
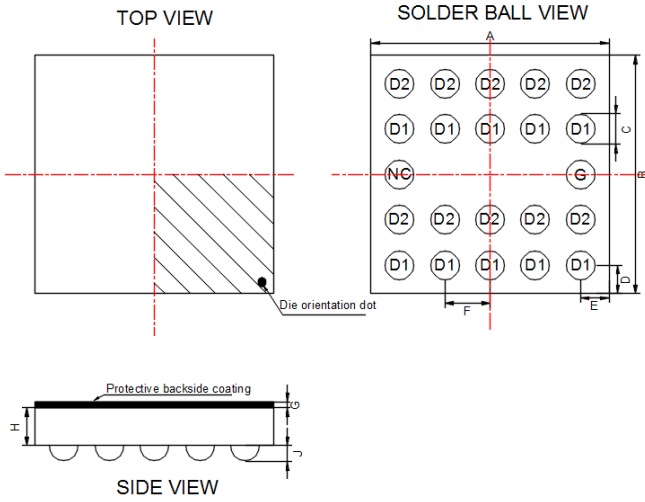

Figure 18 Max. Transient Thermal Impedance



10. Package Outlines

Package Reference



SYMBOL	MILLIMETER		
	MIN	NOM	MAX
A	2.075	2.1	2.125
B	2.075	2.1	2.125
C	0.241	0.268	0.295
D	0.25 REF		
E	0.25 REF		
F	0.4 BASIC		
G	0.022	0.025	0.028
H	0.330	0.344	0.358
J	0.165	0.195	0.225

NOTE:

- 1) ALL DIMENSIONS ARE IN MILLIMETERS.
- 2) BALL COPLANARITY SHALL BE 0.01 MILLIMETERS MAX.
- 3) COMPLIES WITH JEDEC MO-211.
- 4) DRAWING IS NOT TO SCALE.

Marking Reference:

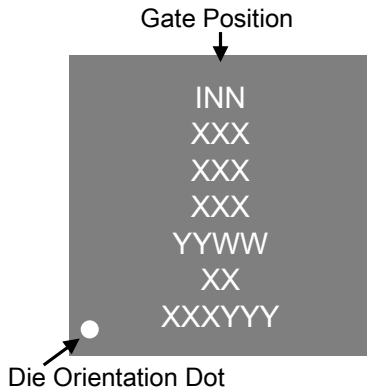

Row	Description	Example
Row 1	Company name	INN
Row 2	Product code	XXX
Row 3	Lot code	XXX
Row 4		XXX
Row 5	Date code	YYWW
Row 6	Wafer ID	XX
Row 7	Location ID	XXXYYY

INN040W048A

40V Bi-directional GaN Enhancement-mode Power Transistor

11. Reel Information

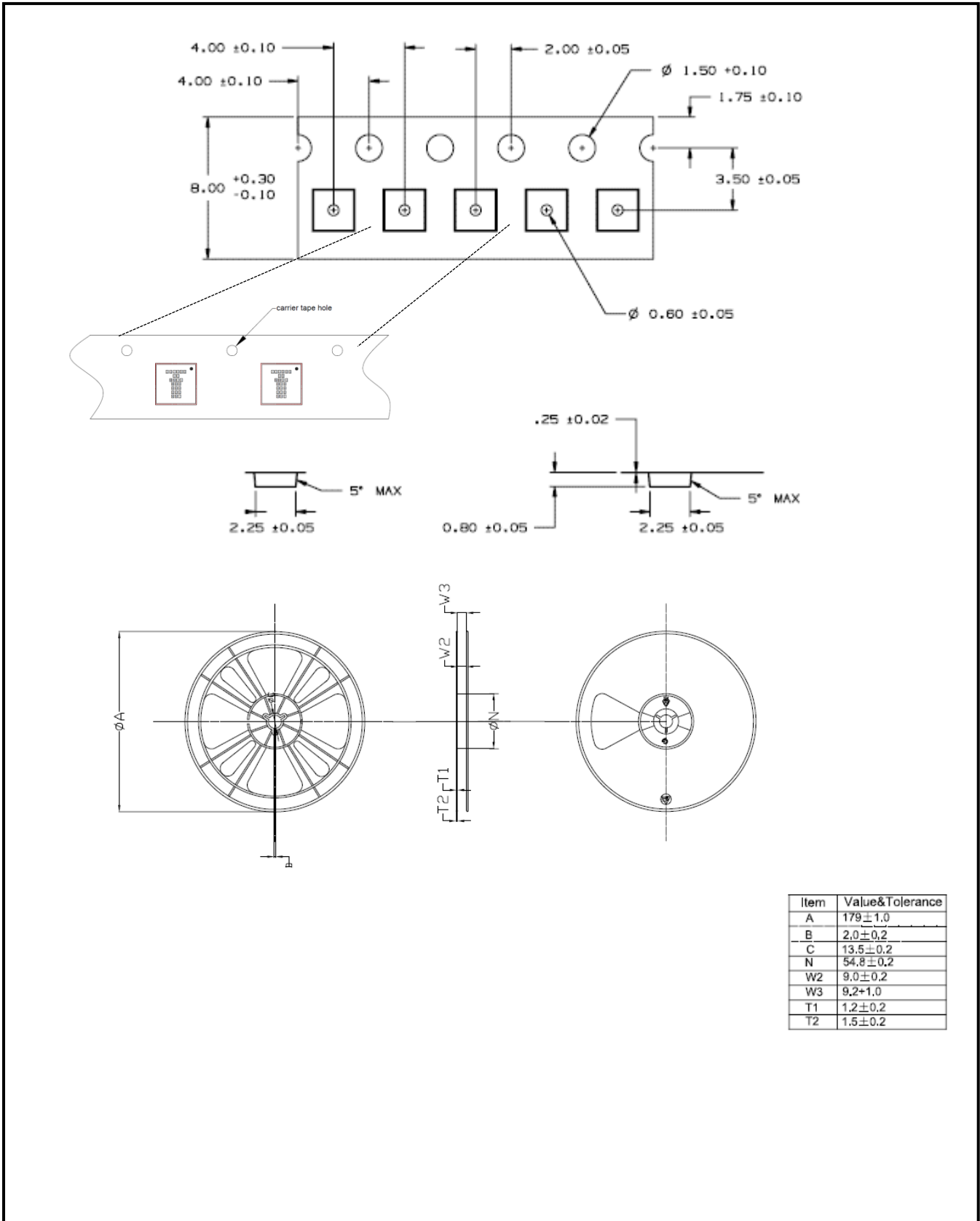

12. Land Pattern

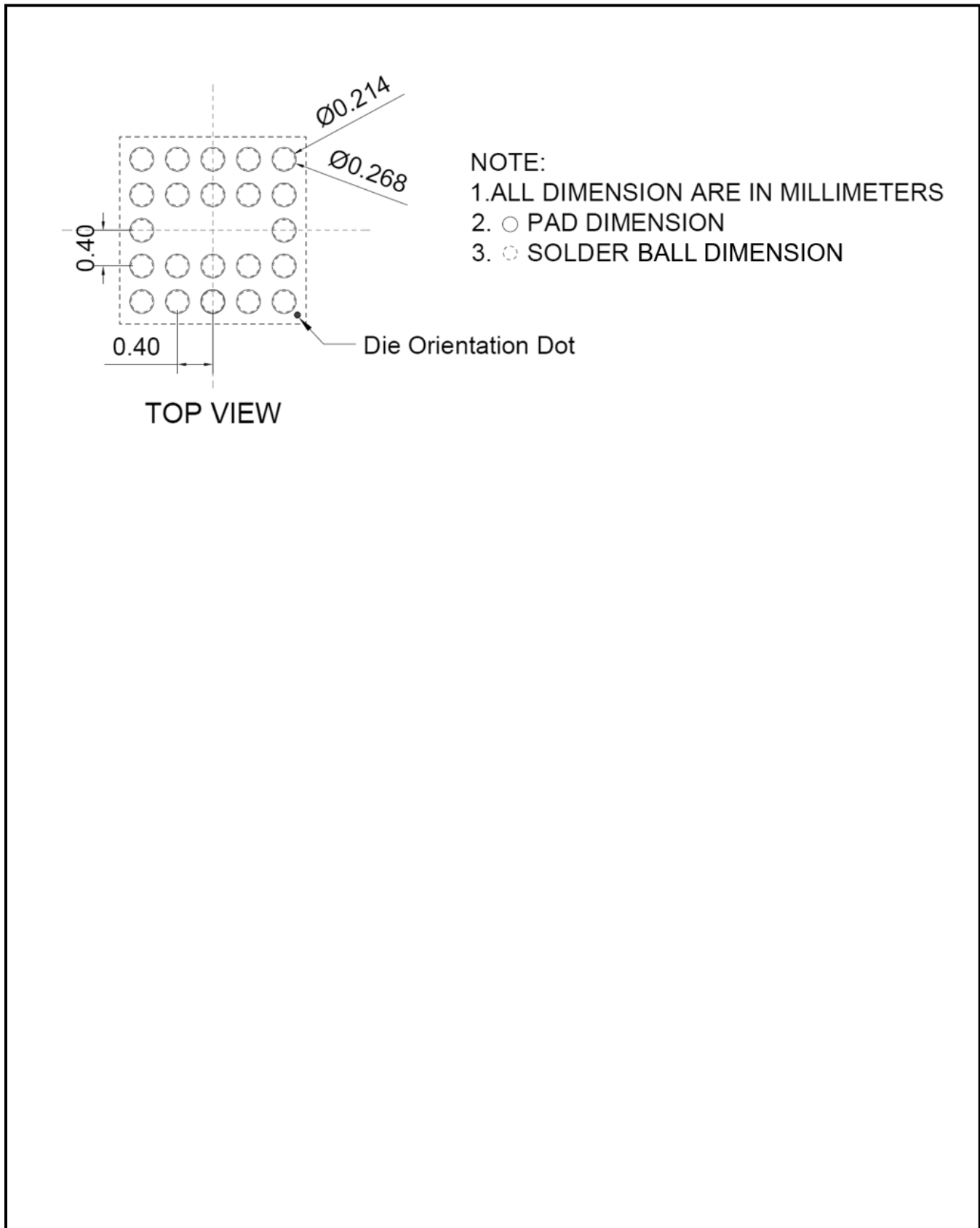

13. Revision History

Major changes since the last revision

Revision	Date	Description of changes
1.0	2022-04-28	1.0 version release
1.1	2022-06-30	Updated land pattern information
1.2	2023-08-14	<ol style="list-style-type: none">1. Updated format and corrected typos2. Added P_{tot} in Maximum Ratings3. Corrected description 'D' to 'D1', 'S' to 'D2' in Electric Characteristics Diagrams4. Updated Note in Electric Characteristics Diagrams