

INN040W120A

40V Bi-directional GaN Enhancement-mode Power Transistor

INN040W120A

1. General Description

Bi-directional GaN-on-Silicon enhancement mode high-electron-mobility-transistor (HEMT) in WLCSP with 1.2 mm x 1.7 mm package size.

2. Features

- Bi-directional blocking capability
- GaN-on-Silicon E-mode HEMT technology
- Ultra-low on resistance

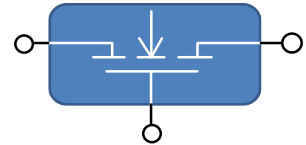

3. Applications

- High side load switch
- OVP protection in smart phone USB port
- Switch circuits in multiple power suppliers system

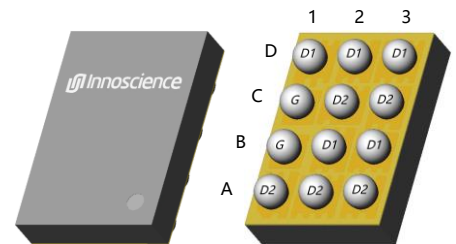

4. Key Performance Parameters

Table 1 Key performance parameters at $T_J = 25\text{ }^\circ\text{C}$

Parameter	Value	Unit
$V_{DD,max}$	40	V
$R_{D1D2(on),max}$ @ $V_G = 5\text{ V}$	12	m Ω
$Q_{G,typ}$ @ $V_{DD} = 20\text{ V}$	7.2	nC
$I_{D,DC}$	10	A

5. Pin Information

Table 2 Pin information

Pin	Pin description	Pin function
D1~3, B2~3	Drain1	Power Drain1
C2~3, A1~3	Drain2	Power Drain2
B1, C1	Gate	Driver Gate

Table 3 Ordering information

Type/Ordering Code	Package	Product Code
INN040W120A	WLCSP 1.2x1.7	D19

Table of contents

1. General Description	1
2. Features	1
3. Applications	1
4. Key Performance Parameters	1
5. Pin Information	1
6. Maximum Ratings	3
7. Thermal Characteristics	4
8. Electric Characteristics	5
9. Electric Characteristics Diagrams	7
10. Package Outlines	12
11. Reel Information	13
12. Land Pattern	14
13. Revision History	15

INN040W120A

40V Bi-directional GaN Enhancement-mode Power Transistor

6. Maximum Ratings

at $T_J = 25\text{ }^\circ\text{C}$ unless otherwise specified.

Continuous application of maximum ratings can deteriorate transistor lifetime. For further information, contact Innoscience sales office.

Table 4 Maximum ratings

SYMBOL	PARAMETER	MAX	UNIT
V_{DD}	Drain1-to-Drain2 Voltage or Drain2-to-Drain1 Voltage	40	V
V_{DG}	Drain-to-Gate Voltage	40	V
V_{GD}	Gate-to-Drain Voltage	6	V
I_D	Continuous Drain current (limited by solder ball)	10	A
I_{DM}	Pulsed Drain Current (25°C , $T_{Pulse} = 300\ \mu\text{s}$)	50	A
P_{tot}	Power dissipation ($T_{c, bottom} = 25^\circ\text{C}$)	11	W
T_J	Operating Temperature	-40 to 125	$^\circ\text{C}$
T_{STG}	Storage Temperature	-40 to 150	$^\circ\text{C}$

INN040W120A

40V Bi-directional GaN Enhancement-mode Power Transistor

7. Thermal Characteristics

Table 5 Thermal characteristics

SYMBOL	PARAMETER	TYP	UNIT
$R_{\theta JC_top}$	Thermal Resistance, Junction to Case (top)	1.4	$^{\circ}C/W$
$R_{\theta JC_bot}$	Thermal Resistance, Junction to Case (bottom)	8.88	$^{\circ}C/W$
$R_{\theta JA}$	Thermal Resistance, Junction to Ambient ¹	67.35	$^{\circ}C/W$

Note 1: $R_{\theta JA}$ is determined with the device mounted on one square inch of copper pad, single layer 2 oz copper on FR4 board.

INN040W120A

40V Bi-directional GaN Enhancement-mode Power Transistor

8. Electric Characteristics

at $T_J = 25\text{ }^\circ\text{C}$, unless specified otherwise

Table 6 Static characteristics

SYMBOL	PARAMETER	MIN	TYP	MAX	UNIT	TEST CONDITIONS
BV_{D1D2S}	Drain1-to-Drain2 Breakdown Voltage	40			V	$V_{D2} = V_G = 0\text{ V}$, $I_{D1D2} = 500\text{ }\mu\text{A}$
BV_{D2D1S}	Drain2-to-Drain1 Breakdown Voltage	40			V	$V_{D1} = V_G = 0\text{ V}$, $I_{D2D1} = 500\text{ }\mu\text{A}$
I_{D1D2S}	Zero Gate Voltage Drain Current			20	μA	$V_{D2} = V_G = 0\text{ V}$, $V_{D1} = 40\text{ V}$
I_{D2D1S}	Zero Gate Voltage Drain Current			20	μA	$V_{D1} = V_G = 0\text{ V}$, $V_{D2} = 40\text{ V}$
I_{GDS} ($T_J = 85\text{ }^\circ\text{C}$)	Gate-to-Drain Leakage		0.5	5	μA	$V_{D1} = V_{D2} = 0\text{ V}$, $V_G = 5\text{ V}$
	Gate-to-Drain Leakage	-30			μA	$V_{D1} = V_{D2} = 0\text{ V}$, $V_G = -5\text{ V}$
I_{GDS} ($T_J = 85\text{ }^\circ\text{C}$)	Gate-to-Drain Leakage		5	30	μA	$V_{D1} = V_{D2} = 0\text{ V}$, $V_G = 6\text{ V}$
	Gate-to-Drain Leakage	-40			μA	$V_{D1} = V_{D2} = 0\text{ V}$, $V_G = -6\text{ V}$
$V_{GD1(TH)}$	Gate Threshold Voltage	0.8		2.4	V	$V_{D1} = 0\text{ V}$, $V_{D2} = V_G$, $I_{D2D1} = 1\text{ mA}$
$V_{GD2(TH)}$	Gate Threshold Voltage	0.8		2.4	V	$V_{D2} = 0\text{ V}$, $V_{D1} = V_G$, $I_{D1D2} = 1\text{ mA}$
$R_{D1D2(on)}$	Drain1-to-Drain2 On-state Resistance		9	12	m Ω	$V_{D2} = 0\text{ V}$, $V_{GD} = 5\text{ V}$, $I_{D1D2} = 10\text{ A}$
$R_{D2D1(on)}$	Drain2-to-Drain1 On-state Resistance		9	12	m Ω	$V_{D1} = 0\text{ V}$, $V_{GD} = 5\text{ V}$, $I_{D2D1} = 10\text{ A}$

INN040W120A

40V Bi-directional GaN Enhancement-mode Power Transistor

Table 7 Dynamic characteristics

SYMBOL	PARAMETER	MIN	TYP	MAX	UNIT	TEST CONDITIONS
C _{ISS}	Input Capacitance		405		pF	V _G = 0 V, V _D = 20 V
C _{OSS}	Output Capacitance		174			
C _{RSS}	Reverse Transfer Capacitance		104			
R _G	Gate Resistance		3.5		Ω	f = 1 MHz
Q _G	Total Gate Charge		7.2		nC	V _D = 20 V, V _G = 5 V, I _D = 10 A
Q _{GD1}	Gate-to-Drain1 Charge (V _{D2D1} =20V)		0.9			V _{D1} = 0, V _{D2} = 20 V, I _{D2D1} = 10 A
Q _{GD1}	Gate-to-Drain1 Charge (V _{D1D2} =20V)		3.9			V _{D2} = 0, V _{D1} = 20 V, I _{D1D2} = 10 A
Q _{GD2}	Gate-to-Drain2 Charge (V _{D1D2} =20V)		0.9			V _{D2} = 0, V _{D1} = 20 V, I _{D1D2} = 10 A
Q _{GD2}	Gate-to-Drain2 Charge (V _{D2D1} =20V)		3.9			V _{D1} = 0, V _{D2} = 20 V, I _{D2D1} = 10 A
Q _{OSS}	Output Charge		5.6			V _G = 0 V, V _D = 20 V

INN040W120A

40V Bi-directional GaN Enhancement-mode Power Transistor

9. Electric Characteristics Diagrams

at $T_J = 25\text{ }^\circ\text{C}$, unless specified otherwise

Note: In Charts, VD1D2 can be VD2D1 with same characteristic chart due to Bi-directional feature.

Figure 1 Typical Output Characteristics ($T_J = 25\text{ }^\circ\text{C}$)

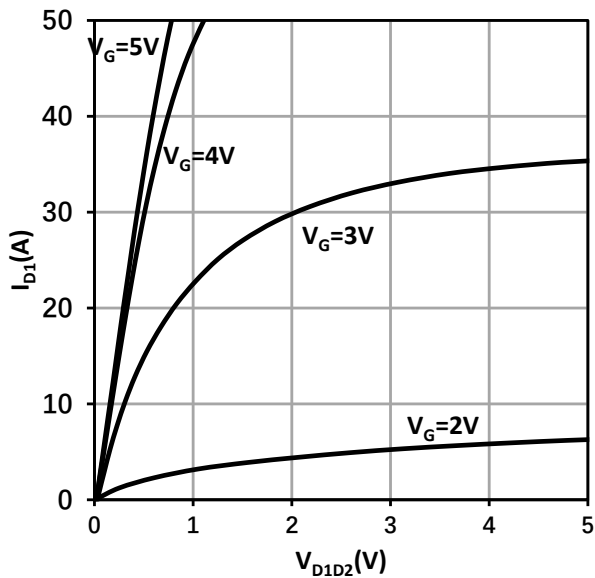

Figure 2 Typical Output Characteristics ($T_J = 125\text{ }^\circ\text{C}$)

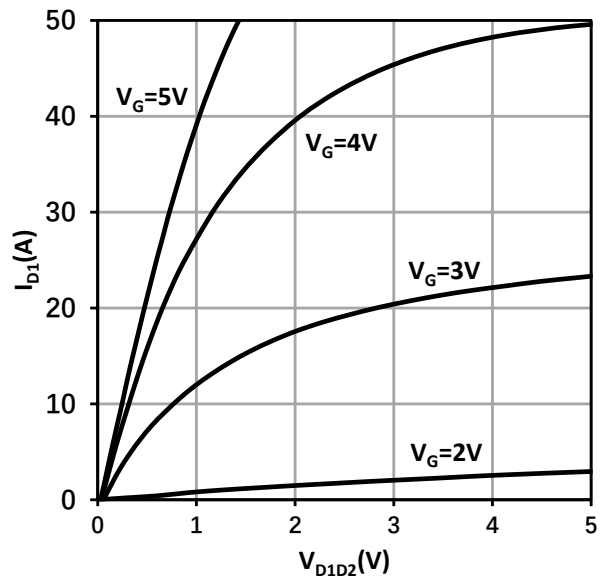

Figure 3 Typical Drain On-state Resistance ($T_J = 25\text{ }^\circ\text{C}$)

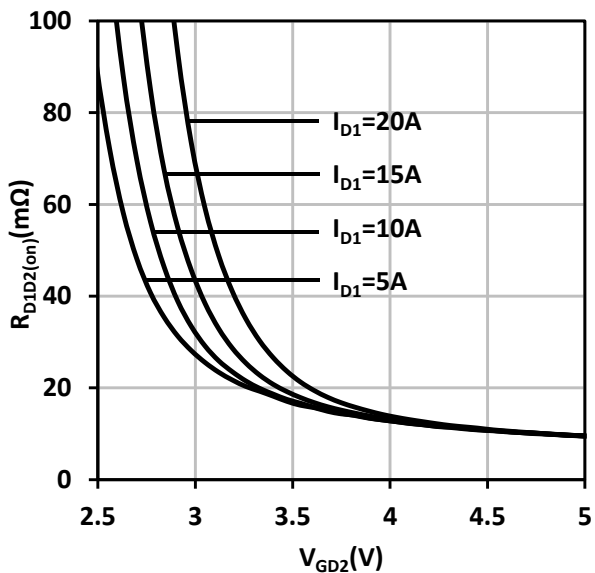
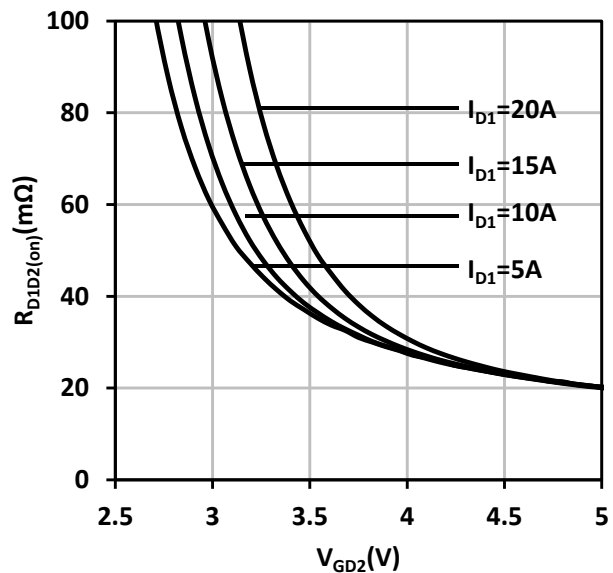

Figure 4 Typical Drain On-state Resistance ($T_J = 125\text{ }^\circ\text{C}$)



INN040W120A

40V Bi-directional GaN Enhancement-mode Power Transistor

Figure 5 Typical On Resistance vs. Temperature

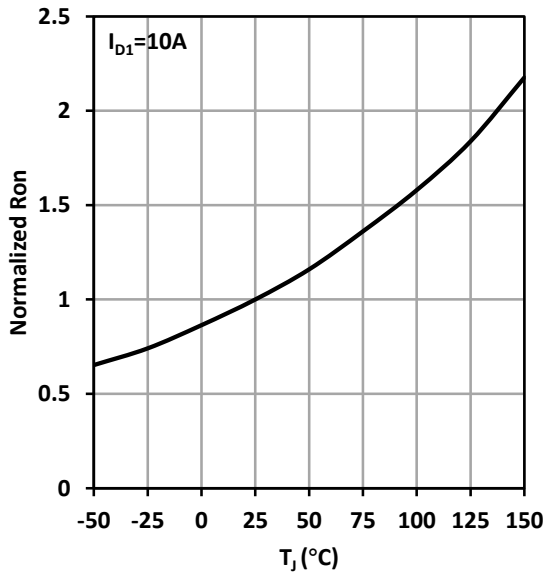

Figure 6 Typical Transfer Characteristics

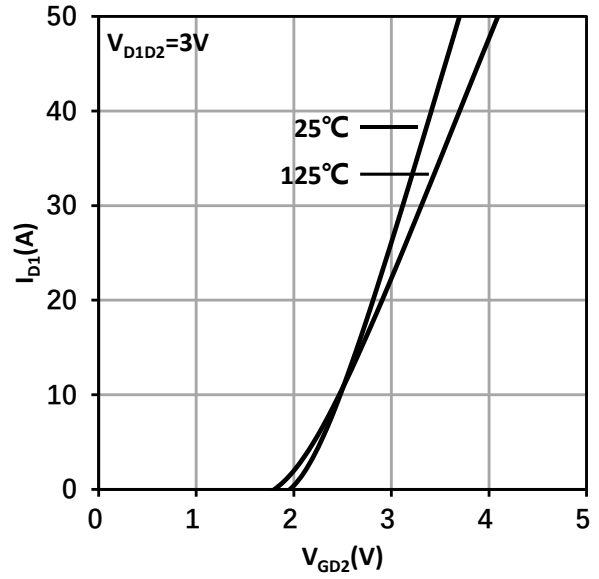

Figure 7 Typ. Reverse Drain1- Drain2 Characteristics ($V_{GD2} \leq 0V$, $T_J = 25^\circ C$)

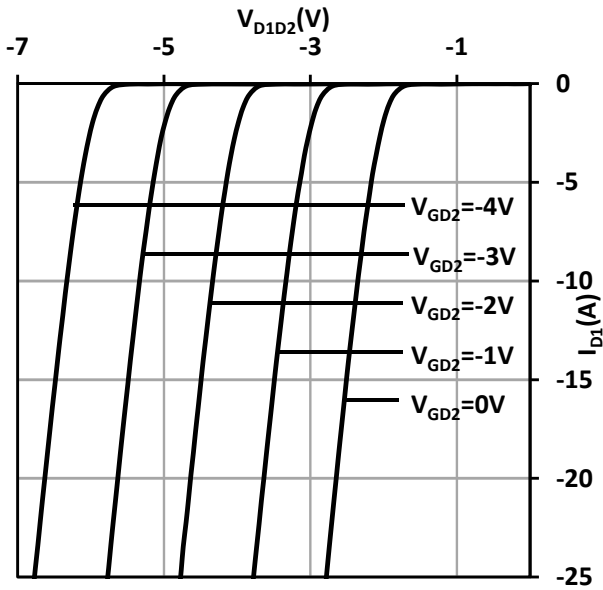
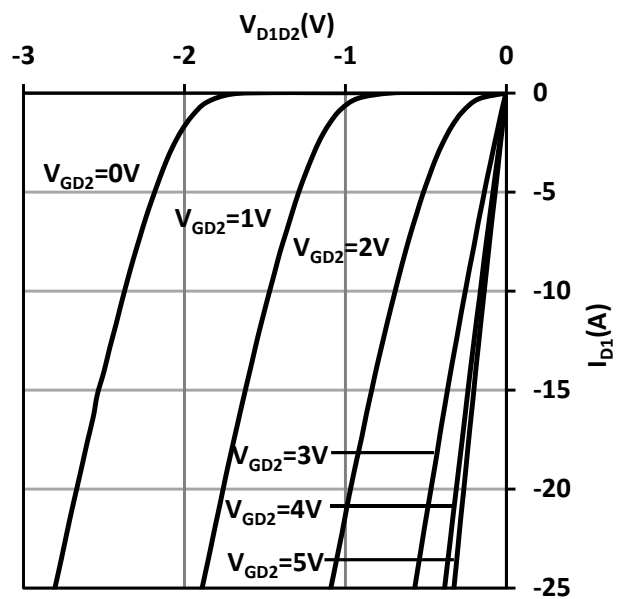

Figure 8 Typ. Reverse Drain1- Drain2 Characteristics ($V_{GD2} \geq 0V$, $T_J = 25^\circ C$)



INN040W120A

40V Bi-directional GaN Enhancement-mode Power Transistor

Figure 9 Typ. Reverse Drain1- Drain2 Characteristics ($V_{GD2} \leq 0V$, $T_J = 125\text{ }^\circ\text{C}$)

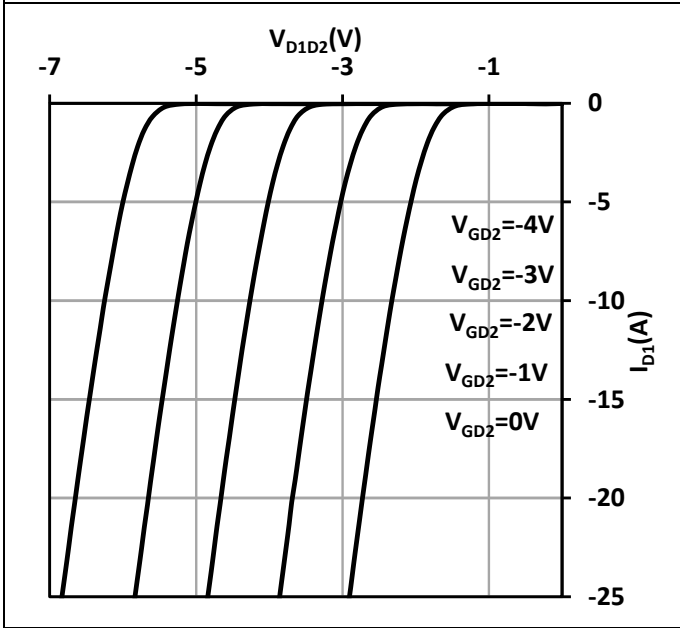

Figure 10 Typ. Reverse Drain1-Drain2 Characteristics ($V_{GD2} \geq 0V$, $T_J = 125\text{ }^\circ\text{C}$)

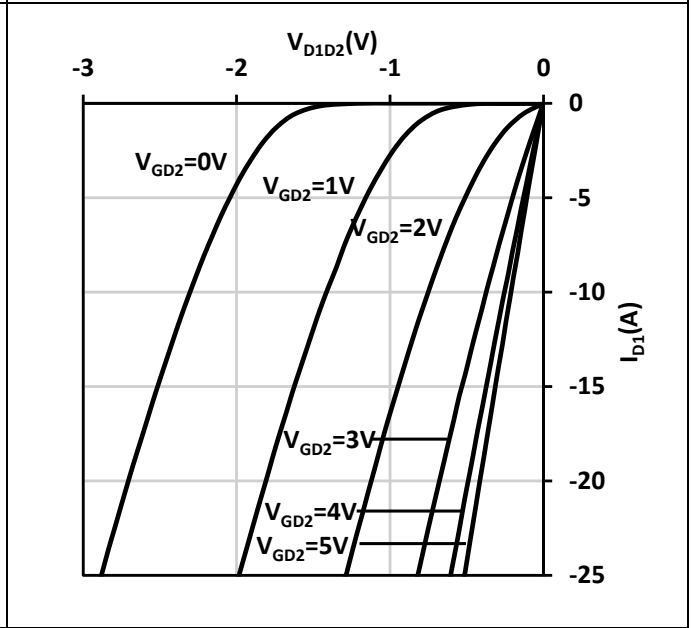

Figure 11 Typ. Capacitances Characteristics

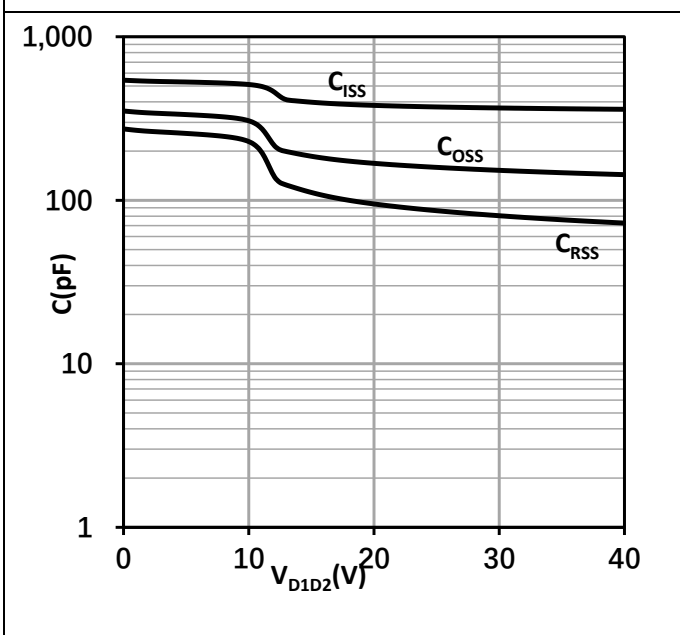
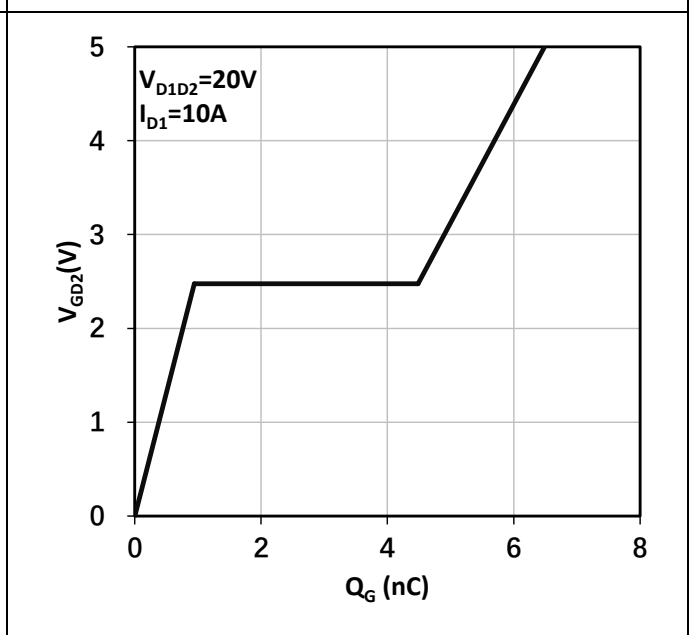

Figure 12 Typ. Gate Charge



INN040W120A

40V Bi-directional GaN Enhancement-mode Power Transistor

Figure 13 Normalized Threshold Voltage vs. Temp.

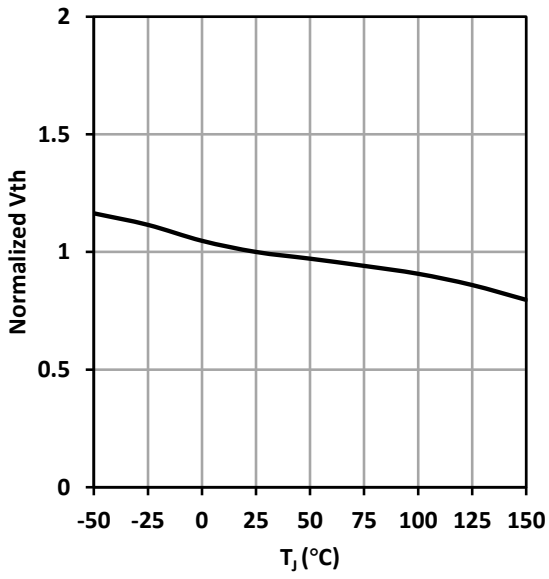

Figure 14 Output Charge

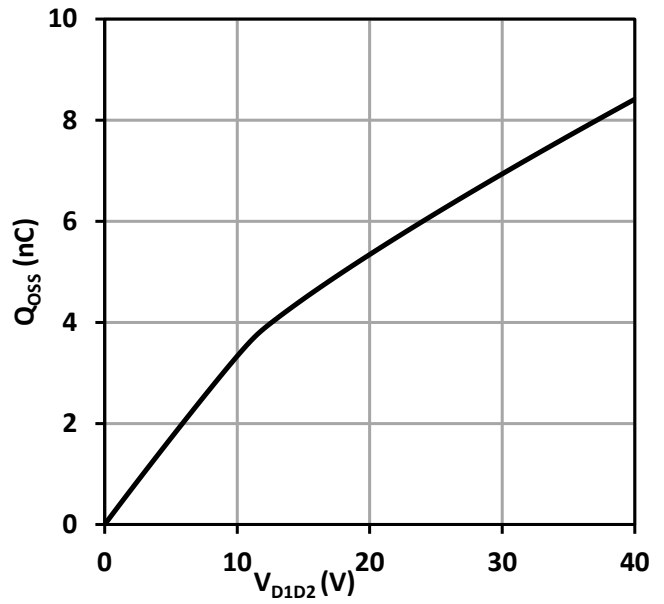

Figure 15 Output Capacitance Stored Energy

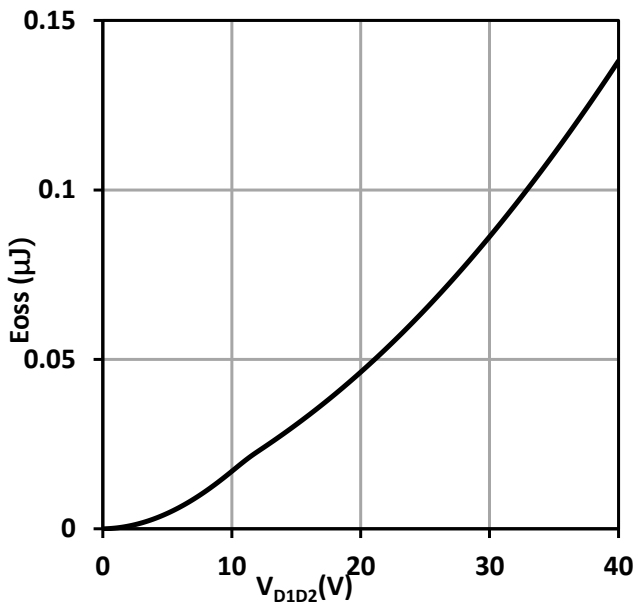
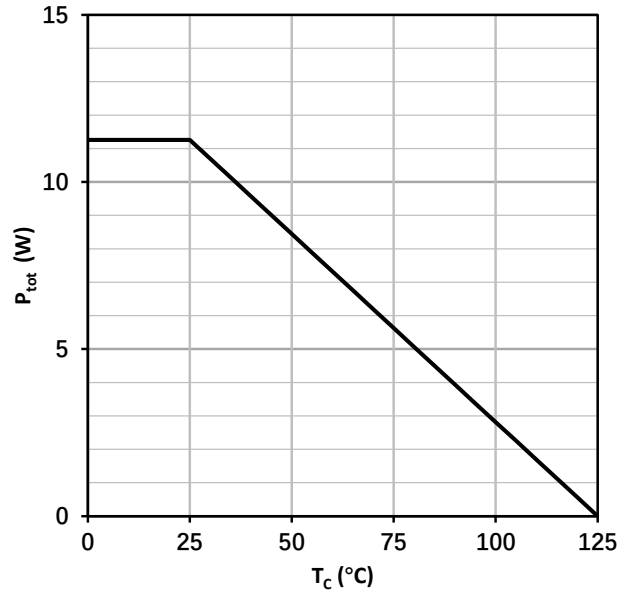

Figure 16 Power Dissipation



INN040W120A

40V Bi-directional GaN Enhancement-mode Power Transistor

Figure 17 Safe Operating Area

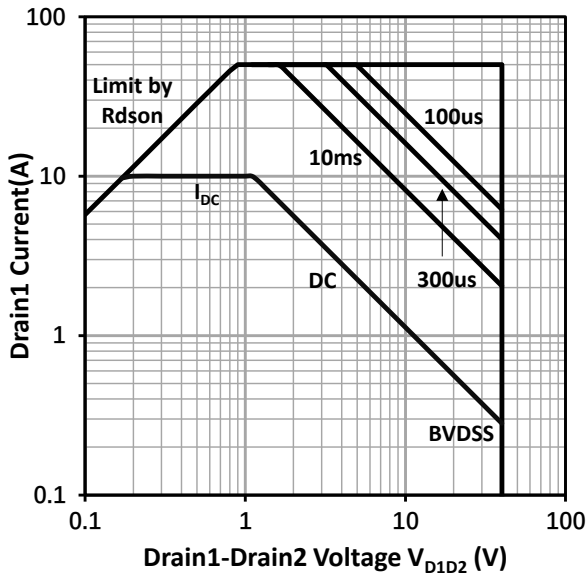
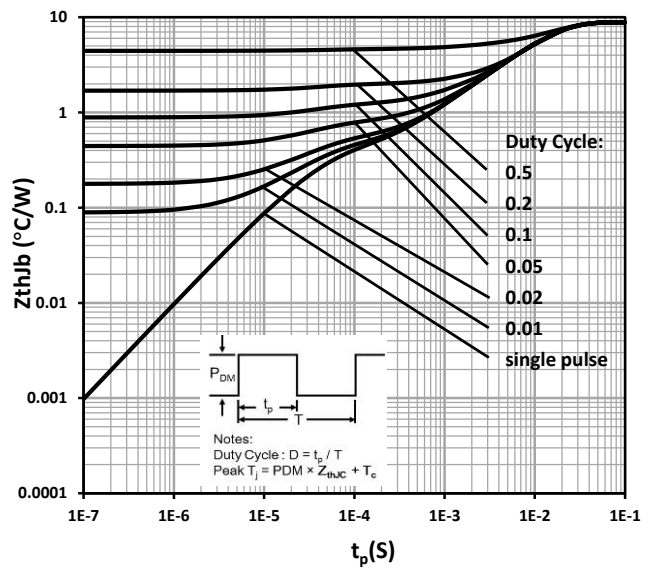

Figure 18 Max. Transient Thermal Impedance



INN040W120A

40V Bi-directional GaN Enhancement-mode Power Transistor

10. Package Outlines

Package Reference

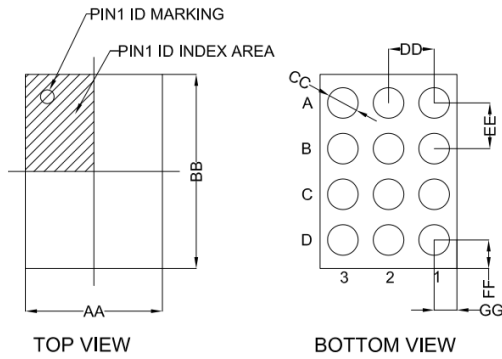

SYMBOL	MILLIMETER			NOTE
	MIN	NOM	MAX	
AA	1.175	1.200	1.225	
BB	1.675	1.700	1.725	
CC	0.241	0.268	0.295	12X
DD	0.400 BASIC			8X
EE	0.400 BASIC			9X
FF	0.250 REF			4X
GG	0.200 REF			4X
J	0.175	0.205	0.235	
H	0.517	0.564	0.611	

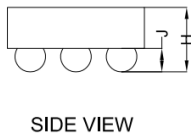

NOTE:

- 1) ALL DIMENSION ARE IN MILLIMETERS.
- 2) BOTTOM VIEW IS SOLDER BAR VIEW.
- 3) COMPLIES WITH JEDEC MO-211.
- 4) DRAWING IS NOT TO SCALE.
- 5) A,B IS PACKAGE SIZE
- 6) BAR COPLANARITY SHALL BE 0.05 MILLIMETERS MAX

Marking Reference:

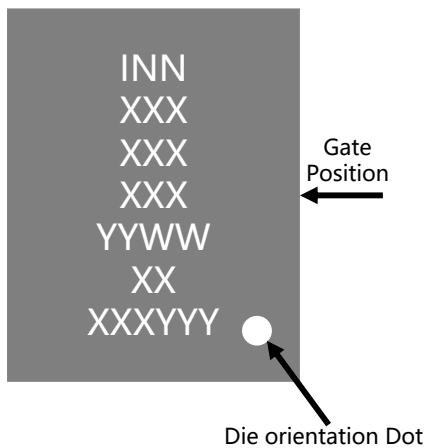

Row	Description	Example
Row 1	Company name	INN
Row 2	Product code	XXX
Row 3	Lot code	XXX
Row 4		XXX
Row 5	Date code	YYWW
Row 6	Wafer ID	XX
Row 7	Location ID	XXXYYY

INN040W120A

40V Bi-directional GaN Enhancement-mode Power Transistor

11. Reel Information

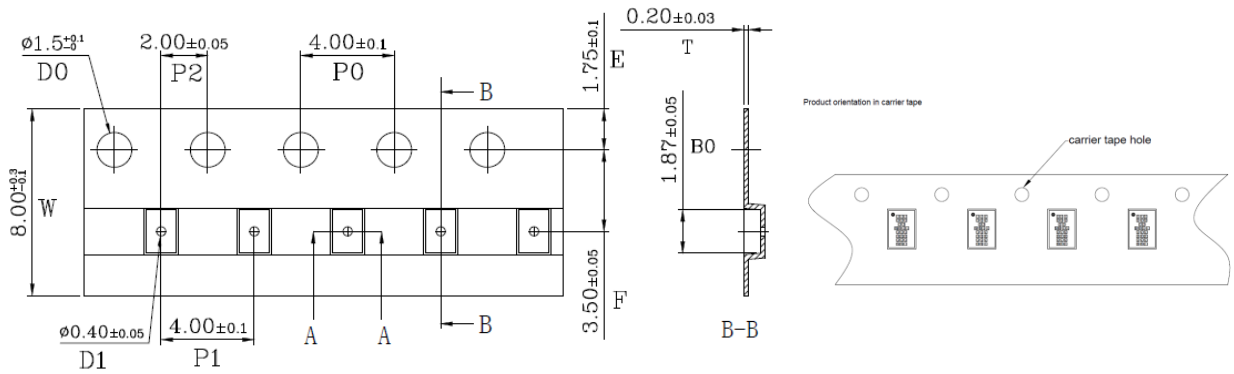

Unit: mm

W	P1	E	F	D0	D1	P0	P2	10P0
$8.00^{+0.3}_{-0.1}$	4.00 ± 0.10	1.75 ± 0.10	3.5 ± 0.05	$1.50^{+0.10}_{-0}$	0.4 ± 0.05	4.0 ± 0.1	2 ± 0.05	40 ± 0.2
A0	A1	B0	B1	K0	K1	T		
1.31 ± 0.05		1.87 ± 0.05		0.71 ± 0.05		0.20 ± 0.03		

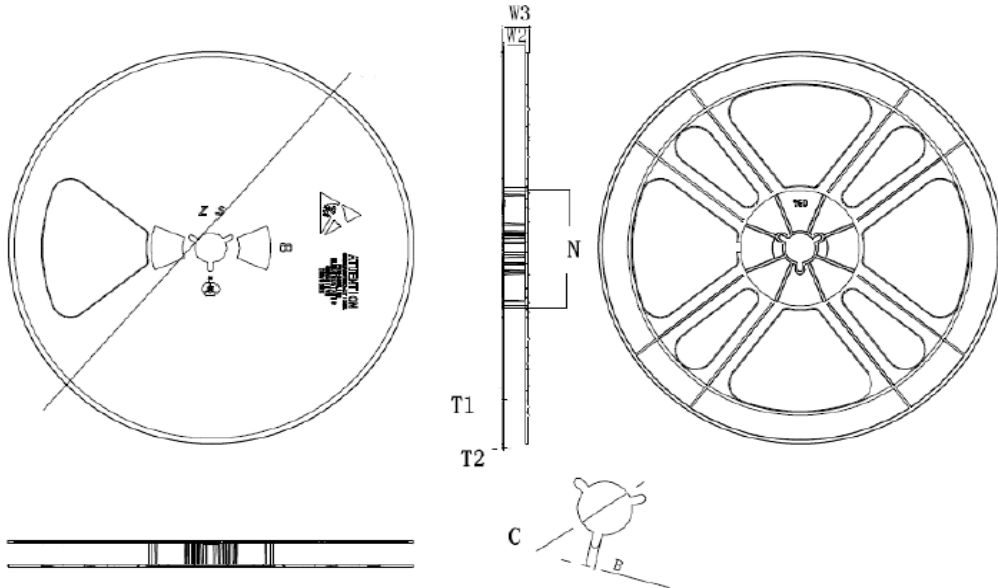

TYPE	A	N	W2	W3	T1	T2	C	B
8	179 ± 1	54.8 ± 0.2	9.0 ± 0.2	9.2 ± 1.0	1.2 ± 0.2	1.5 ± 0.2	13.5 ± 0.2	2.0 ± 0.2

12. Land Pattern

Recommended Land Pattern

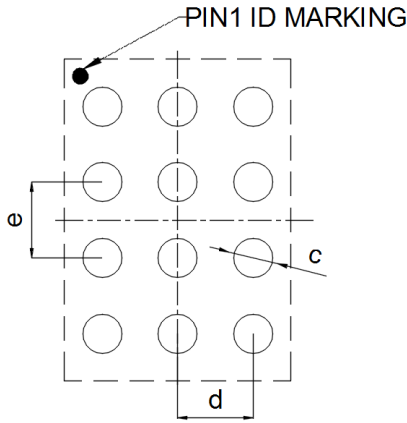

SYMBOL	MILLIMETER	NOTE
	NOM	
c	0.214	12X
d	0.400 BASIC	8X
e	0.400 BASIC	9X

TOP VIEW

NOTE:

- 1) LAND PATTERN IS SOLDER MASK DEFINED.
- 2) IT IS RECOMMENDED TO HAVE ON-CU TRACE PCB VIAS.

Recommended Stencil Drawing

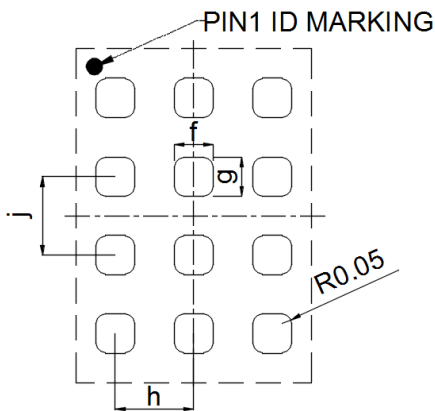

SYMBOL	MILLIMETER	NOTE
	NOM	
f	0.200	12X
g	0.200	12X
h	0.400 BASIC	8X
j	0.400 BASIC	9X

TOP VIEW

13. Revision History

Major changes since the last revision

Revision	Date	Description of changes
1.0	2023-02-10	1.0 version release
1.1	2023-08-14	<ol style="list-style-type: none">1. Updated format and corrected typos2. Added P_{tot} in Maximum Ratings3. Corrected description 'D' to 'D1', 'S' to 'D2' in Electric Characteristics Diagrams4. Updated Note and Typ. Reverse diagrams in Electric Characteristics Diagrams